

Version 7A
January 30, 2008

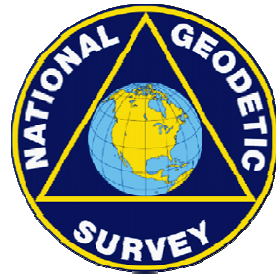

**SCOPE OF WORK
GROUND SURVEYS**
for
**U.S. DEPARTMENT OF COMMERCE
NATIONAL OCEANIC AND ATMOSPHERIC ADMINISTRATION
NATIONAL OCEAN SERVICE
NATIONAL GEODETIC SURVEY**

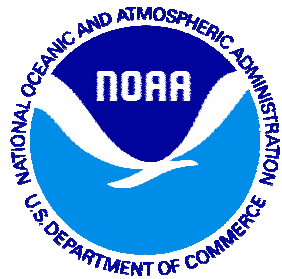

TABLE OF CONTENTS

SUBJECT	PAGE
1. INTRODUCTION.....	5
2. ADMINISTRATION.....	5
2.1 SPECIFICATIONS.....	5
2.2 CONVENTIONS.....	5
2.3 GENERAL REQUIREMENTS.....	6
2.4 MODIFICATIONS.....	6
2.5 UNUSUAL CIRCUMSTANCES.....	6
2.6 REPORTS.....	6
2.7 ORIGINAL DATA.....	6
3. GOVERNMENT SUPPLIED MATERIALS.....	6
3.1 TRANSMITTAL LETTER.....	6
3.2 PROJECT INSTRUCTIONS.....	6
3.3 BRASS DISKS.....	6
3.4 LOGO CAPS.....	7
4. REFERENCE SYSTEMS.....	7
4.1 HORIZONTAL REFERENCE.....	7
4.2 VERTICAL REFERENCE.....	7
4.3 REFERENCE SYSTEMS.....	7
4.4 GEOID MODEL.....	7
5. REFERENCES AND GLOSSARY.....	8
5.1 REFERENCES.....	8
5.2 GLOSSARY.....	8
6. QUALITY CONTROL.....	8
7. DATA FORMATS.....	9
7.1 ORIGINAL DATA.....	9
7.2 FINAL DATA.....	9
8. DATA MEDIUM AND FILE NAMING CONVENTION.....	9
8.1 DATA MEDIUM.....	9
8.2 FILE NAMING CONVENTION FOR GPS GROUND SURVEYS.....	9
8.3 FILE NAMING CONVENTION FOR OTHER SURVEYS.....	9
9. SURVEY METHODOLOGY.....	9
10. SURVEY WORK FOR HEIGHT MODERNIZATION.....	10

10.1 PURPOSE.....	10
10.2 PLANNING.....	10
10.3 OFFICE RESEARCH.....	10
10.4 RECONNAISSANCE.....	10
10.5 MARK RECOVERY.....	11
10.6 SURVEY PLAN.....	13
10.7 MARK SETTING OF PERMANENT STATIONS.....	14
10.8 SURVEY OBSERVATIONS.....	15
10.9 DATA PROCESSING.....	17
10.10 DATA ANALYSIS.....	17
10.11 DATA ADJUSTMENT.....	17
10.12 DATA SUBMITTAL.....	17
10.13 MANUALS... ..	17
10.13 TRAINING.....	17
11. FINAL PROJECT REPORT.....	17
12. DELIVERABLES TO NGS.....	19
12.1 LABOR, EQUIPMENT, ETC	19
12.2 GOVERNMENT SUPPLIED ITEMS.....	19
12.3 QUALITY CONTROL PLAN.....	19
12.4 SURVEY PLAN.....	19
12.5 PROJECT STATUS REPORTS.....	20
12.6 PROJECT SKETCH (VECTOR DIAGRAM).....	20
12.7 FIELD LOGS.....	20
12.8 VECTOR PROCESSING OUTPUT.....	20
12.9 REPORTS.....	20
12.10 ADJUSTMENT AND CHECKING PROGRAMS.....	20
12.11 ORIGINAL DATA.....	20
12.12 DESCRIPTIONS.....	20
12.13 TRANSMITTAL LETTER.....	21
12.14 SECURITY REQUIREMENTS.....	21
13. POINTS OF CONTACT.....	21

ATTACHMENTS

- A. AIRPORT GROUND CONTROL SURVEYS
- B. PROJECT SUBMISSION CHECKLIST
- C. WORLD WIDE WEB SITES
- D. STATION SELECTION GUIDELINES
- E. SAMPLE TRANSMITTAL LETTER (BLANK AND FILLED-IN)
- F. EXPLANATIONS OF GOVERNMENT SUPPLIED MATERIALS
- G. STATUS REPORT FORMAT
- H. TECHNICAL PROPOSAL CONTENTS (INCLUDING TOMIS DELIVERABLE TRACKING LOG)
- J. TIDAL COORDINATION REQUIREMENTS
- K. LEVELING SAMPLE FINAL REPORT
- L. HEIGHT MODERNIZATION SURVEYS
- M. SAMPLE STATION TABLE, (BLANK AND FILLED-IN)
- N. SURVEY DISK DIAGRAMS
- O. GROUND PHOTO CONTROL
- P. GROUND SURVEYS V2A
- Q. FORMS
- R. REQUIREMENTS FOR DIGITAL PHOTOGRAPHS V13b
- S. WRITING STATION DESCRIPTIONS WITH WDDPROC V8
- T. SETTING CONCRETE MARKS V2
- U. SETTING A SURVEY DISK IN BEDROCK OR A STRUCTURE
- V. SETTING A NGS 3-D MONUMENT
- W. COMMONLY USED ACRONYMS
- X. BENCH MARK TIES
- Y. MARKS IN OR NEAR BEDROCK
- Z. SUMMARY OF CO-OPS REQUIREMENTS.....

**SCOPE OF WORK
GROUND SURVEYS
for
U.S. DEPARTMENT OF COMMERCE
NATIONAL OCEANIC AND ATMOSPHERIC ADMINISTRATION
NATIONAL OCEAN SERVICE
NATIONAL GEODETIC SURVEY**

1. INTRODUCTION

This Scope of Work (SOW) lists requirements for ground surveys and tide station support needed to support the National Geodetic Survey (NGS), National Oceanic and Atmospheric Administration (NOAA), and other programs. These programs include the Height Modernization Program (HTMOD), the Coastal Mapping Program (CMP), the Aeronautical Survey Program (ASP), research and development projects, and other special projects. Note, no aerial nor satellite data collection is required under this SOW. The types of surveys may include: traditional electro-optical; all types of Global Positioning Systems (GPS), (including hand-held GPS receiver to geodetic quality GPS receiver usage, establishing and using Continuously Operating Reference Stations (CORS), and/or Real-time Kinematic Global Positioning Systems (KGPS); ground laser scanning; hyperspectral ground sampling; and ground control for airborne radar surveys. These surveys may be required to verify existing control, establish new control, and/or to determine ground control for photogrammetric and other remote sensing surveys. Tidal station work may include: installing water level gauges and tidal bench marks, making tidal and leveling observations, making GPS observations on tidal bench marks, and processing this data to include determining tidal datums.

2. ADMINISTRATION

2.1 SPECIFICATIONS – This SOW provides general standards and specifications for the surveys required by NGS. In addition, the Contractor shall be issued a set of Project Instructions for each survey. **The Project Instructions will take precedence over this SOW since the Project Instructions provide detailed and often unique information about each Project.** The requirements for reporting deviations, unusual circumstances, etc., described in the following paragraphs, apply to the SOW and to the Project Instructions.

2.2 CONVENTIONS - The following conventions have been adopted for these project specifications. The verb “shall” means that compliance is required. The verb “should” denotes a recommendation. The contraction “N/A” means “not applicable”. The term “position” means horizontal position (latitude and longitude) unless specified otherwise. The term “elevation” means the distance of a point above a specified datum, measured along the direction of gravity. The term “vertical” refers to the direction in which the force of gravity acts. The term “height” means the distance, measured along a perpendicular, between a point and a

datum. See Section 4. Use the U.S. Survey Foot (3.28083333333 feet = 1 meter) for any length conversions.

2.3 GENERAL REQUIREMENTS - The Contractor shall provide all labor, equipment, supplies, material, and transportation to produce and deliver data and related products as required under this SOW, except as shown in Section 3.

2.4 MODIFICATIONS - All requests for modifications shall be submitted by the Contractor in writing to the Contracting Officer (CO) prior to the Task Order due date and as soon as possible. Send a copy to the NGS Points of Contact (POC) listed in Section 13.

2.5 UNUSUAL CIRCUMSTANCES - The Contractor shall notify the CO and NGS POC of any unusual circumstances that occur during the performance of this SOW or Project Instructions which might affect the deliverables or their quality (see Section 6). Especially note any deviation from this SOW or Project Instructions.

2.6 REPORTS - Thorough reporting is required. The Contractor shall submit weekly project status reports **via TOMIS** (see Section 12.5 and Attachment G) and a Final Project Report (see Section 11) to the contacts in Section 13. In addition, a Quality Control Plan (QCP) (see Section 6), and a Survey Plan (see Section 10.6), shall be submitted. **For information on TOMIS, see Section 12.**

2.7 ORIGINAL DATA - Observation logs and other original records generated during this project are legal records which will be retained for data accountability and stored in the National Archives. Original logs and records shall be submitted and shall be original, legible, neat, clear, accurate, and fully completed in indelible black ink. Original data shall be saved, unmodified, whether in hand-written or computer-recorded form. In the original records (paper or digital), nothing is to be erased or obliterated. All available spaces on the recording forms should be completed. If a mistake is made on a form, draw a single line ~~through the mistake~~ and write the correction above or to the side. If space is too limited to permit a field correction, restart with a new log sheet; however, do not recopy the form in the office in order to make a "clean" copy. An explanatory note should be made for all corrections to the original recorded figures. It is essential that all hand-recorded information be neat and legible. All editing of computer-recorded data shall be done on a copy of the original. Submit the original version of the data, not a handmade copy, a photo-copy, or a digital copy.

3. GOVERNMENT SUPPLIED MATERIALS

The following items will be supplied, if applicable:

3.1 TRANSMITTAL LETTER,

3.2 PROJECT INSTRUCTIONS,

3.3 BRASS DISKS - Disks with factory NGS standard lettering, if required.

3.4 LOGO CAPS - Caps for 3D rod marks, with standard NGS lettering (fits 5" or 6" inside diameter, schedule 40 PVC pipes), if required.

See Attachment F for explanations of items listed above.

The Contractor shall acknowledge receipt of Government Supplied Items by inventorying the shipment, signing the Transmittal Letter, and FAXing the Letter to NGS. At this time contractors can not use TOMIS to acknowledge receipt of Government Supplied Items sent by the Government.

4. REFERENCE SYSTEMS

The following Reference Systems shall be used:

4.1 HORIZONTAL REFERENCE - The North American Datum of 1983 and year of the latest observations which is abbreviated NAD83 (YYYY). Note: the year of observations is on the NGS Data Sheet next to the latitude and longitude.

4.2 VERTICAL REFERENCE -

Orthometric heights - The North American Vertical Datum of 1988 (NAVD 88); for information on NAVD 88, see:

http://www.ngs.noaa.gov/PUBS_LIB/NAVD88/navd88report.htmhttp://www.ngs.noaa.gov/PUBS_LIB/NAVD88/navd88report.htm

Ellipsoidal heights - NAD 83

http://www.ngs.noaa.gov/PC_PROD/WorkShops/PPT/SPCS/sld009.htm

4.3 REFERENCE SYSTEM - Use the National Spatial Reference System (NSRS), see http://www.ngs.noaa.gov/INFO/OnePagers/One-Pager_NSRS.pdf.

Survey control shall be tied to the NGS Continuously Operating Reference Station (CORS) system. For information on CORS, see: <http://www.ngs.noaa.gov/CORS/>.

For information on the High Accuracy Reference Network (HARN), see: <http://www.ngs.noaa.gov/faq.shtml>.

4.4 GEOID MODEL – GEOID 03 for lower 48 states

http://www.ngs.noaa.gov/PC_PROD/GEOID03/, or GEOID 06 for Alaska http://www.ngs.noaa.gov/PC_PROD/GEOID06/, or a later, current version.

For explanations of many of the terms in Section 4, see: <http://www.ngs.noaa.gov:80/faq.shtml>.

5. REFERENCES AND GLOSSARY

5.1 REFERENCES - Note, the Contractor shall become thoroughly familiar with the following references:

A. NOAA Technical Memorandum NOS NGS-58 “Guidelines for Establishing GPS-Derived Ellipsoid Heights (Standards: 2 cm and 5 cm).”

Available on-line at: http://www.ngs.noaa.gov/PUBS_LIB/NGS-58.html .

B. A Guide for Establishing GPS-Derived Orthometric Heights (Standards: 2 cm and 5 cm). See:

http://www.ngs.noaa.gov/PUBS_LIB/DRAFTGuidelinesforEstablishingGPSderivedOrthometricHeights.pdf#search=%22orthometric%20heights%22

C. Input Formats and Specifications of the National Geodetic Survey Data Base, the “Blue Book.” Available on-line at: <http://www.ngs.noaa.gov/FGCS/BlueBook/> .

D. NOAA Manual NOS NGS 1 “Geodetic Bench Marks.” Available on-line at:

http://www.ngs.noaa.gov/PUBS_LIB/GeodeticBMs.pdf .

E. File Naming Convention - See Web site in Section 8.2.

F. Field Guidelines - For information about visibility obstruction diagrams, and other field guidelines, see: <http://www.ngs.noaa.gov/PROJECTS/FBN/> (click on “Forms,” then click on “Visibility Obstruction Diagram”).

G. See also the References listed in Attachment I, Leveling.

5.2 GLOSSARY - Geodetic Glossary, NGS, 1986 (not available on the WWW). For a printed copy, telephone NGS at (301) 713-3242 or email: info_center@ngs.noaa.gov

6. QUALITY CONTROL

The Contractor shall check all data to ensure that it is complete, reliable, and accurate. Note, accuracy requirements may be in the Project Instructions. The Contractor’s personnel shall become thoroughly familiar with the SOW; the Attachments; the Project Instructions; the definitions of surveying terms; and the material covered in the other references and publications, as required. See Section 5 for a list of References and Glossary.

QUALITY CONTROL PLAN - Prior to beginning survey work on this project, the Contractor shall submit a written Quality Control Plan (QCP) **covering all work**. The QCP shall describe how the Contractor shall meet the technical specifications required for the project. The QCP shall include at least the following requirements: a check of all manual computations (including check marks and initials), a check of all manual data computer entries, a check of file formats, and a check of all reports and data submitted. The contractor shall also describe how data will

be backed up and how it will be ensured that original data are not modified. See Section 12, Deliverables. Note, the QCP in the Technical Proposal may be used to meet this requirement if it includes all items listed above.

Comments on quality control and a copy of the QCP will be included in the Final Project Report.

7. DATA FORMATS

7.1 ORIGINAL DATA - Original, raw digital data shall be submitted and their formats shall be documented in the Final Project Report. Original paper records shall also be submitted; see Section 2.7. Observations for positioning permanently marked points shall be submitted in Blue Book format. Note, all Blue Book projects are required to include ties to CORS.

7.2 FINAL DATA - Final project data for permanently marked points shall be submitted in Blue Book format, or in other formats specified by this SOW or the Project Instructions (for example, digital photographs).

8. DATA MEDIUM AND FILE NAMING CONVENTION

8.1 DATA MEDIUM - CD-ROM or DVD

8.2 FILE NAMING CONVENTION FOR GPS GROUND SURVEYS - See the naming convention for Federal Base Network (FBN) projects on NGS' Web site at: <http://www.ngs.noaa.gov/PROJECTS/FBN/>

8.3 FILE NAMING CONVENTION FOR OTHER SURVEYS - Provide an explanation for all file names and formats.

9. SURVEY METHODOLOGY

The survey methodology may vary with the project. The Project Instructions may specify a methodology, otherwise the Contractor shall recommend a methodology in the Survey Plan. GPS ground surveying methods shall be used for HTMOD work specified in References A and B, Section 10, and the Project Instructions. The types of surveys may include: traditional electro-optical surveys, all types of GPS surveys, ground laser scanning, hyperspectral ground sampling (on the ground), and ground control for airborne radar surveys. These surveys may be used to establish new control, and to determine ground control for photogrammetric and other remote sensing surveys.

10. SURVEY WORK

10.1 PURPOSE – Ground surveys may be needed to support National Geodetic Survey and other NOAA programs. These programs include the HTMOD, CMP, ASP, research and development projects, and other special projects. These surveys shall be tied to the NSRS. The NSRS, with NAVD 88 as its elevation reference, provides the Nation with a common, consistent set of real-time geographical coordinates (reference points). Blue Book projects are required to have CORS ties.

A Ground Survey Project may include: planning, office research, reconnaissance, mark recovery, preparation of a Survey Plan, mark setting, electro-optical survey observations, GPS survey observations, spirit leveling, ground laser scanning, data processing, data checking, data analysis, data adjustment, data submittal in specified formats, preparing reports, writing manuals and other training aids explaining the work, and providing training on how to accomplish the work.

10.2 PLANNING – Office planning includes determination of survey methodologies, instruments and equipment, time frame, transportation, marks **or CORS** to use for connection to NSRS, software for data collection and data processing.

10.3 OFFICE RESEARCH – Office research includes searching databases for survey control, maps, and other required information. NGS and U. S. Coast and Geodetic Survey (USC&GS) (former name for NGS) station descriptions are contained in the NGS database and are available via the NGS Web site. A database search shall be made for all control stations within the project area (defined in the Project Instructions) as required for each project. Access the NGS Integrated Data Base (NGSIDB) using the NGS Web site at: <http://www.ngs.noaa.gov/cgi-bin/datasheet.prl>. Note, the Contractor may need to search the databases of other organizations (for example, a state survey office or that of another federal agency).

10.4 RECONNAISSANCE – Survey control requirements will vary with the type of survey project. Existing horizontal and/or vertical control stations may be required. Some projects may require connection to CORS, FBN, Cooperative Base Network (CBN), HARN, Primary Airport Control Station (PACS), NAVD 88 geodetic bench marks, and/or tidal bench marks. All horizontal and vertical points used as control shall be part of the NSRS.

A. VISIBILITY DIAGRAM - For all permanent marks planned to be occupied by GPS, recovered and proposed, a visibility obstruction diagram is required using the form found at: <http://www.ngs.noaa.gov/PROJECTS/FBN/> (click on “Forms,” then click on “Visibility Obstruction Diagram”).

B. PENCIL RUBBINGS - Rubbings are no longer required during the recovery of a survey mark. Rubbings are required at the time of each observation at that station.

C. PHOTOGRAPHS

- i. Recovered stations - The contractor shall take at least three photographs of each existing control station per Attachment R.
- ii. Proposed sites of new permanent marks - Take two photographs of proposed sites, one at eye level, oriented vertically downward showing the ground in the area of the proposed mark (photo type #2) and one oriented horizontally showing the nearest satellite obstruction or identifying feature if no obstructions (photo type #3).
- iii. New Marks after set - Capture photo (type #1) and update others as required. Note, see Attachment R for complete digital photograph requirements.
- iv. Concrete mark hole- One photo, with a level rod in the hole showing the depth of the hole.

D. PROPOSED NEW PERMANENT MARK SITES - It is highly preferable to use existing marks rather than set new marks. The contractor shall propose sites for new permanent stations as required and propose the type of mark to be set. Preliminary digital descriptions shall be prepared as well as visibility diagrams and photographs.

E. GPS POSITIONS - Obtain a hand-held GPS (pseudo-range) position for all marks found and for proposed sites for new marks. Include this position in the text of recovery notes and descriptions. Data format: DDD MM SS.ss. Upon returning to the station, the Contractor shall use the description to find the station (and thus check the description) and not rely strictly on the GPS position.

10.5 MARK RECOVERY – A search in the field for the survey mark and written comments on that search.

A. SEARCH - The contractor shall make an extensive physical search in the field for all control stations required for the project. See Attachment N for diagrams of NOAA survey disks. Before an existing mark is used, its description shall be thoroughly checked to confirm the station's identity, stability, and location, and to provide input for an updated description or recovery note. Stamping shall not be done on existing disks or logo caps. The contractor shall prepare digital updated descriptions or recovery notes for all NSRS marks searched for and all marks used in the project. See Section 10.5H below entitled “MARK RECOVERY DEFINITION.”

B. VISIBILITY – Horizontal and vertical stations selected for GPS surveys should have adequate GPS satellite visibility. The visibility should be minimally restricted from 15 degrees above the horizon to the zenith, in all directions; see Attachment D for additional details. Minor obstructions are acceptable, but shall be depicted on the Visibility Obstruction Diagram. For new stations, select a site relatively free of present and future anticipated obstructions. Utility poles in the GPS field of view are tolerable, and they provide security and a reference to help locate the mark. Set new marks at least

2 meters from a pole, to the south if possible. Likewise, existing marks within 2 meters of a pole should not be used. Marks should not be set or used if within 5 meters of a chain link fence.

C. MARKS OF OTHER ORGANIZATIONS - Other marks may be used if they meet NGS stability, visibility, spacing, accuracy, and other requirements.

D. MARKS ON PRIVATE PROPERTY - The Contractor shall contact property owners and obtain permission before using or setting a mark on private property. Take care to return the landscape to the original condition. Clean up any excess materials and supplies remaining after setting a mark. Do NOT include the name and phone number of the property owner in the station description unless the land is owned by a business or government agency, or the owner requests to have the information included in the description.

E. HORIZONTAL CONTROL - A sufficient number of stations shall be recovered to provide horizontal control for the project. If there is insufficient horizontal control for the project, the contractor shall extend the area of the search until enough control is found. Notify NGS of this situation immediately.

F. VERTICAL CONTROL - A sufficient number of stations (bench marks) shall be recovered to provide vertical control for the project, if required. If there is insufficient vertical control for the project, the contractor shall extend the area of the search until enough control is found. Notify NGS of this situation immediately.

G. BENCH MARK SPIRIT LEVEL TIES - If the reconnaissance indicates that the number and/or distribution of bench marks with good sky visibility is inadequate, spirit level ties may be made to transfer an elevation from a bench mark to a nearby existing or new survey point that does have good sky visibility. Every effort should be made to recover existing bench marks before using this method. Transferring elevations to existing horizontal control marks is preferable to setting new marks. Temporary marks shall not be used. The project instructions may require these ties to be made using first-, second-, or third-order specifications and standards. For third-order ties, see Attachment X.

H. MARK RECOVERY DEFINITION - The “recovery” of a control station includes a physical visit to the station to determine its usability by checking its identity, ascertaining its unmoved position, and determining its condition, stability, visibility, etc. and to prepare a digital updated description or recovery note in NGS format. To ascertain its identity, check the mark type (concrete post, disk in drill hole, rod, etc.), disk type (see Attachment N), and stamping against the NGS data sheet. To ensure its position, measure the distances from the reference marks and/or the distances from the reference points and Witness Post. Also, the angle between the reference marks could be checked. Station descriptions and recovery notes shall be submitted in computer-readable form using WinDesc software available on-line at: http://www.ngs.noaa.gov/PC_PROD/pc_prod.shtml#WinDesc . WDDPROC may also

be used. http://www.ngs.noaa.gov/PC_PROD/DDPROC4.XX/ddproc.index.html. See detailed instructions in Attachment S. Note, for non-Blue Booked projects with only Recovery Notes, the NGS on-line “Mark Recovery Entry” system may be used. Submit a paper copy of any on-line submittals. See: http://www.ngs.noaa.gov/FORMS_PROCESSING-cgi-bin/recvy_entry_www.prl .

I. MARKS RECOVERED BUT NOT USABLE - For marks which are recovered but are positively not usable due to complete tree canopy, etc., the recovery requirements may be reduced to just a simple recovery note such as, “RECOVERED AS DESCRIBED. THE MARK CAN NOT BE OCCUPIED BY GPS DUE TO COMPLETE TREE CANOPY.” For marginally usable marks, fulfill the normal recovery requirements including Visibility Diagram, photographs, etc. because the mark may be needed depending on other marks in the area.

J. DESTROYED SURVEY MARKS - Metal survey disks which have been moved, are very loose, or otherwise damaged so that they can no longer serve as survey marks are to be removed, have updated recovery notes written describing the mark as destroyed, and the disk sent to NGS. A mark shall not be described as destroyed unless the disk is found and returned to NGS.

K. DAMAGED SURVEY MARKS - Any existing disk which is selected to be used should be repaired if found loose (but still in original position) or with edges exposed. Any work done to repair a disk shall be described completely in the digital recovery note. Extreme care shall be taken not to alter the existing horizontal or vertical position of the disk. Disk longevity can be increased substantially by simply adding highway epoxy or the equivalent when the edges of a disk are exposed, thus preventing ice from forming under the disk and/or a vandal from prying the disk from its location.

If marks are found that require major repairs, report this to NGS. Mark repair may be required by the Project Instructions. Examples of mark maintenance problems include: loose disk, exposed edge of disk, missing logo cap, missing logo cap lid, exposed edge of concrete monument, or imminent danger of destruction. Contact NGS for recommendations in unusual cases.

L. MARKS NOT FOUND - As stated in Section 10.5A, the contractor shall make an extensive physical search for control stations. If the mark is not found, enter the number of person-hours spent searching into the digital recovery note. Do not state that the mark is destroyed simply because it was not found. If strong evidence exists that the mark has been destroyed, state the evidence.

10.6 SURVEY PLAN - After reconnaissance and mark recovery but prior to setting permanent marks or making survey observations on permanent marks, the contractor shall submit a Survey Plan (digital copy) to the NGS POC. NGS will review the Plan as soon as possible, normally within ten work days, and will send the contractor written comments and/or approval. The

contractor shall not begin mark setting or data collection until the Plan is approved by NGS. The Plan shall include at least the following sections:

ITEM

- A. Text with summary of survey planning, including survey methodology (electro-optical, kinematic GPS, etc.),
- B. Station table (see details below and sample in Attach. M),
- C. Original recovery notes on NGS Station Description/Recovery Note Form,
- D. Digital recovery notes from WINDESC or WDDPROC,
- E. Recovery note submitted on NGS web site,
- F. Original descriptions on NGS Station Description/Recovery Note Form,
- G. Digital preliminary station descriptions from WinDesc or WDDPROC,
- H. GPS satellite visibility diagrams, for old and proposed new stations,
- I. Project Sketch, to scale (different symbols for old and new station locations), and indicating how stations are connected during the primary, secondary, & local surveys,
- J. Digital photographs, print all for one mark on one page,
- K. Proposed instrumentation (receivers and antennas),
- L. Proposed data collection and processing software,
- M. Detailed survey observation plan, and
- N. Detailed tidal plans.

Submit paper and digital copies of all above items.

Note, printouts of the NGS station data sheet are not required.

A Station Table shall be submitted for all projects where permanent marks will be set. The Station Table shall include the station designation (name), PID (Permanent Identifier), type (FBN, PACS, etc.), establishing agency, order, stability, condition at recovery, and comments/recommendations. For new stations, include the proposed name in the "Name" column, identify them as "proposed" in the "Type" column, and **indicate the proposed type of mark (rod, concrete, disk in bedrock) in the "Comments/Recommendations" column.** For existing stations, the name and PID shall be used exactly as listed in the NGS database and shall be this way in all survey records. For existing stations found but not proposed to be used, state the reason(s) in the "Comments/Recommendations" column. See sample in Attachment M.

10.7 MARK SETTING OF PERMANENT STATIONS - After the Survey Plan is approved by NGS, the Contractor may begin field work. Blue-booking (entering data into NGS' data entry format) is not required for check points, ground photo control points, or for temporary survey points. See requirements in Attachments T, U, & V.

A. TEMPORARY MARKS – Temporary marks may be acceptable for photo control and similar lower accuracy surveys. The Contractor should mark all points with a physical mark such as an iron pin or PK type nail. NGS approval of the Survey Plan is not required for the contractor to set this type of mark.

B. PERMANENT MARKS – Marks for higher accuracy surveys such as Height Modernization surveys shall be set to NGS specifications for type, length, material, stability, stamping, driving, etc. outlined in "Geodetic Bench Marks" and Attachments T, U, & V. Per Attachment V, Section 4.3/11, the rod is driven to refusal, or until a

driving rate of 60 seconds per foot is achieved. After this is achieved, the minimum acceptable length for the required “B” stability rod mark is normally 4 meters; see reference “Geodetic Bench Marks,” page 27, Table 3 (in other words, a rod driven to refusal that is less than 4 meters long is not acceptable). In cases where bedrock is encountered at or near the ground surface, see Attachment Y, “Marks In Or Near Bedrock”.

The preliminary station descriptions shall be updated after the mark is set, and photograph #1 (close-up, see Attachment R) shall be captured along with updates of other photographs, as required. For concrete marks, take a photograph after the hole is dug and before the concrete is poured showing a level rod in the hole (to show the depth of the hole). The file name for this photo will start with “RE” for reconnaissance; see Attachment R. NGS approval of the Survey Plan is required prior to the contractor setting this type of mark.

10.8 SURVEY OBSERVATIONS – Survey observations methodologies will vary depending on the project area and the accuracy required. See the Project Instructions for possible additions or changes to the requirements.

A. ROUTINE SURVEYS – Photo control and other surveys requiring lower accuracies may be observed with less sophisticated equipment and procedures than higher accuracy surveys. For these type surveys, third-order conventional (electro-optical) or kinematic GPS surveys may be adequate. Temporary survey points may suffice for these surveys. Fixed height tripods are recommended but not required. NSRS ties should be made by using CORS and On-line Positioning User Service (OPUS), including OPUS-Rapid Static (OPUS-RS).

B. HIGH ACCURACY SURVEYS - For high accuracy GPS surveys (such as HARN or Height Modernization surveys), GPS data shall be collected using GPS equipment meeting the following criteria: the receiver model shall have been evaluated against the Federal Geodetic Control Subcommittee (FGCS) test network, shall be a state-of-the-art, dual-frequency receiver with high quality C/A code or P code pseudo-ranges, shall be capable of measuring full wavelength L2 carrier phase, shall function acceptably in an Anti-Spoofing environment, and shall consist of a geodetic quality antenna with ground plane designed to reduce multi-path, and shall have an antenna model that has been calibrated by NGS. NSRS ties shall be made by using CORS

i. Tripods - Fixed height tripods shall be used for high accuracy surveys.

Tripods with multiple height settings should be set to the highest position. All tripods shall be tested for stability, plumb alignment (straightness of center pole), and height verification at the beginning and end of the project. All tripods shall be examined for stability with each use. Ensure that hinges, clamps, and feet are secure and in good repair. Also, check, and adjust if necessary, the position of the bubble in the circular vial.

ii. Observation form- The Contractor shall use the NGS GPS observation form found at: <http://www.ngs.noaa.gov/PROJECTS/FBN/> (Click on “Forms,” then click on “GPS Observation Log”).

iii. Pencil rubbings- The contractor shall capture a pencil rubbing of a marks’ stamping (disk or logo cap) each time the mark is occupied for observations. Use the form found at: <http://www.ngs.noaa.gov/PROJECTS/FBN/> (Click on “Forms,” and then click on “Pencil Rubbing Form”). When not feasible to make the required rubbing, a sketch of the mark shall be substituted accurately recording all markings.

C. TIDE/WATER LEVEL REQUIREMENTS - When required, specifications for predicting water levels, observing water levels in real time, installing water level gauges and tidal bench marks, collecting these data, GPS observations on tidal bench marks, and processing these observations will be included in the Project Instructions. Data shall be submitted in NOAA, Center for Operational Oceanographic Products and Services (CO-OPS) and NGS specified formats. In any cases where the requirements conflict or would cause duplicate effort, contact NGS for clarification. See Attachment J for information on tidal acquisition windows and Attachment P for information on GPS ties to tidal bench marks. For additional information on tides and water levels, see the CO-OPS site at: <http://www.co-ops.nos.noaa.gov/>, especially the link to “Our Restless Tides” at: <http://www.co-ops.nos.noaa.gov/restles1.html> , and “Fantastic Tidal Datums at: http://tidesandcurrents.noaa.gov/publications/fantastic_tidal_datums.pdf . For a summary of CO-OPS surveying related requirements, see Attachment Z.

Note, predicted tides may not be accurate in time or height.

The following is from the CO-OPS Frequently Asked Questions section on the CO-OPS WWW site.

Q: How accurate are the predictions?

(Answer from the NOAA CO-OPS web site): The accuracy of the tide predictions is different for each location. Periodically we do a comparison of the predicted tides vs. the observed tides for a calendar year. The information generated is compiled in a Tide Prediction Accuracy Table. We work to insure that the predictions are as accurate as possible. However, we can only predict the astronomical tides we cannot predict the effect that wind, rain, freshwater runoff, and other short-term meteorological events will have on the observed tides.

In general, predictions for stations along the outer coast are more accurate than those for stations farther inland; along a river, or in a bay or other estuary. Inland stations tend to have a stronger non-tidal influence; that is, they are more susceptible to the effects of wind and other meteorological effects than stations along the outer coast. An example of an inland station which is difficult to predict is Baltimore, Maryland. This station is located at the northern end of Chesapeake Bay. Winds which blow along the length of

the bay have been known to cause water levels to be 1-2 feet above or below the predicted tides.

Stations in relatively shallow water, or with a small tidal range, are also highly susceptible to meteorological effects and thus difficult to accurately predict. At these stations, short-term weather events can completely mask the astronomical tides. Many of the stations along the western Gulf of Mexico fall into this category. An example is Galveston, Texas. This station is in a bay which is relatively shallow and has a small opening to the sea. At this station it is possible for meteorological events to delay or accelerate the arrival of the predicted tides by an hour or more.

10.9 DATA PROCESSING – Data processing will vary with the survey equipment and methods used.

A. ROUTINE SURVEYS – Usage of CORS and the NGS OPUS (and OPUS-RS) is recommended. Otherwise, standard industry procedures should be followed and all methods and procedures documented in the Final Report.

B. HIGH ACCURACY SURVEYS – For GPS vector processing procedures, see [Attachment L](#).

10.10 DATA ANALYSIS - For lower accuracy surveys, use industry standard procedures. For high accuracy surveys, such as HtMod, see the specifications in Attachment L.

10.11 DATA ADJUSTMENT - For lower accuracy surveys, no adjustment may be necessary, especially for surveys processed using OPUS. For high accuracy surveys, such as HtMod, see the specifications in Attachment L.

10.12 DATA SUBMITTAL – Original data and final, processed data shall both be submitted. Final data for permanently marked points shall be submitted in Blue Book format. The Project Sketch, descriptions, photos, project adjustments, reports, etc., shall be both paper and digital, if possible. Submit all original data records, see Sections 2.7, 7.1, and 10.12. All Deliverables shall be submitted through TOMIS, see Section 12 for additional information.

10.13 MANUALS - The contractor may be required to produce manuals and other training aids (such as Power Point presentations) explaining various survey methods in portions or in its entirety.

10.14 TRAINING - The contractor may be required to conduct training courses using the above materials.

11. FINAL PROJECT REPORT

The Final Project Report for surveys shall contain at least the following sections:

- A. An overview discussion of the planning, field work, data collection, data processing, adjustment, and data error analysis. This discussion should include a summary of the results, problems encountered, conditions affecting progress, and any unusual circumstances. Include comments on any deviations from the Survey Plan, Project Instructions, or this SOW (include comments from weekly Status Reports).
- B. A written description and analysis of the quality control performed; tables showing check positions; a listing and analysis of all unusual circumstances, discrepancies, and deviations; and the QCP.
- C. A listing of personnel who worked in the field and/or were involved with the data processing for this project.
- D. A listing of the brand, model number, and serial number of all survey equipment (GPS receivers, antennas, levels, etc.) used in the project. List the quantity, brand, type, and height of tripods used. Include any instrumentation used for differential leveling if done.
- E. A listing of all software, including version, used during the project.
- F. A final station list: use a table format to list each station and each observation session for the station.
- G. A final Project Sketch (Vector Diagram): update the vector diagram submitted with the Survey Plan (see Section 10.6). Submit only a large size, readable plot (approximately 24 x 32 inches). Include processing session designations on the vectors if feasible. Note, a digital vector diagram may be required.
- H. For high accuracy surveys, submit the vector processing scheme, observation time for the vector, solution type (ion-free, fixed, etc.), and final RMS for the vector. Provide any comments on problems encountered or anomalies with the processing session.
- I. A list of the comparison of all repeat GPS base lines.
- J. For higher accuracy surveys, submit a detailed description of the project adjustment. Discuss each of the adjustments separately, including fixed control and the source of the coordinates, ellipsoid heights, and NAVD 88 elevation used.
- K. A completed Project Submission Checklist, see Attachment B. Also available on-line at: <http://www.ngs.noaa.gov/FGCS/BlueBook/> (Click on “Annex L” and scroll down to page 9).
- L. Recommendations for future projects.

12. DELIVERABLES TO NGS

The web-based Task Order Management and Information System (TOMIS) is designed to help manage geospatial services contracts for the National Ocean Service. TOMIS allows Government contractors to submit and track deliverables, as well as monitor deliverables that are upcoming or delinquent. E-mail notifications remind contractors when actions are required and contractors will be evaluated on their performance at the completion of all task orders, with a score automatically generated via TOMIS. The TOMIS system is located at <https://maps.csc.noaa.gov/TOMIS/index2.jsp>.

The Contractor shall submit all task order deliverables and progress reports to NGS using the TOMIS system. All progress reports shall be submitted directly to TOMIS by 2:00 pm EST every Monday, and not via email as formerly required. All deliverables smaller than 3 MB in size shall be submitted to TOMIS as an attachment. If the deliverable is over 3 MB (or hardcopy) the contractor shall submit a report to TOMIS expressly stating what the deliverable is and how the deliverable is being delivered, i.e. via FedEx, FTP, etc. Once the deliverable is received by NGS, NGS will mark it as received in TOMIS and TOMIS will send an e-mail confirming receipt of the deliverable.

The contractors shall submit a deliverable tracking spreadsheet in the TOMIS format (the format will be supplied with the Project Instructions). The percentages assigned to each of the deliverables in the spreadsheet will be used as a basis for payment. The Government will not pay an invoice unless a deliverable has been received and at least partially accepted. The last 10% of payment shall be assigned to the shipment of the Government Supplied Materials back to the government. The contractor will be held accountable to the dates that are placed in the spreadsheet. If the contractor determines that they will not be able to meet a due date, it is their responsibility to request an extension.

TOMIS will track the submission dates of all deliverables, and the subsequent review comments generated when deliverables are submitted. As a last step the information within TOMIS will be used to generate a final evaluation for the project.

12.1 - LABOR, EQUIPMENT, ETC. – The contractor shall provide all labor, equipment, supplies, materials, and transportation to produce and deliver the products as required under this SOW, except as shown in the Government Supplied Items in Section 3.

12.2 GOVERNMENT SUPPLIED ITEMS - The contractor shall return all government supplied records (listed in Section 3) and all unused survey marks and logo caps to NGS.

12.3 QUALITY CONTROL PLAN - Before any field work begins, the Contractor shall submit to NGS a Quality Control Plan (QCP) covering all work (see Section 6). NGS will review this plan and respond with an approval or comment letter (or email) as soon as possible, normally within ten working days. The QCP in the Technical Proposal may be used to fulfill all or part of this requirement. Submit paper and digital copies.

12.4 SURVEY PLAN - Before any permanent mark setting or GPS observations on permanent marks begin, the Contractor shall submit a Survey Plan (see Sections 10.6) to NGS. NGS will

review this plan and respond with an approval or comment via TOMIS as soon as possible, normally within ten working days. Field work may commence after the Contractor receives the approval and the Task Order, if required. See Section 10.6 for a listing of which items are to be submitted on paper and which in digital format.

12.5 PROJECT STATUS REPORTS - The Contractor shall submit project status reports via TOMIS every Monday afternoon by 2:00 P.M. Eastern Time, from the date of the Task Order until the work is complete. See Attachment G for detailed requirements.

12.6 PROJECT SKETCH (VECTOR DIAGRAM) - Submit a sketch (vector diagram for GPS surveys) showing all survey connections. Submit only a large size, readable plot (approximately 24 x 32 inches). Include processing session designations on the vectors if feasible. Submit a paper version and a digital version, if possible.

12.7 FIELD LOGS - Submit the original version of all the field records, including observation logs, pencil rubbing forms, hand-written station descriptions/recovery notes, visibility diagrams, digital photographs, etc.

12.8 VECTOR PROCESSING OUTPUT – For higher accuracy surveys, submit paper copies of the COMBINED.SUM files for any processing sessions that were difficult to process or produced questionable results. Submit paper copies of any other files requested by NGS for quality control.

12.9 REPORTS - Submit a Final Project Report covering surveys; see Section 11.

12.10 ADJUSTMENT AND CHECKING PROGRAMS – For high accuracy GPS projects, submit a paper copy of the output for programs COMPGB, NEWCHKOB, OBSCHK, OBSDES, CHKDESC, BBACCUR, and ELLACC. Submit paper copies of all ADJUST files. Also, submit the digital data sheet or coordinate file for stations used for fixed control during the adjustment (CORS log/coordinate sheets, NGS data sheet for HARN and bench mark coordinates, etc.).

12.11 ORIGINAL DATA - For high accuracy GPS projects, submit all the original, raw data, RINEX data, precise ephemeris, and vector files. Include the CORS RINEX data files used for processing. For all RAW and RINEX data files not named by their occupied station four character ID, submit an index of station names to RAW and RINEX file.

12.12 DESCRIPTIONS – For permanently marked points, submit the finalized description file from the WinDesc or WDDPROC software. Submit both paper and digital formats. This includes the recovery notes submitted with the Survey Plan and the final version of the descriptions of new marks, written after the marks are set. Note, descriptions and recovery notes should be written by one person and checked, in the field, by another. For lower accuracy surveys without Blue-booking requirements, recovery notes may be submitted using the NGS On-Line “Mark Recovery Entry” system, see:

http://www.ngs.noaa.gov/FORMS_PROCESSING-cgi-bin/recvy_entry_www.prl

12.13 TRANSMITTAL LETTER – With the new TOMIS system, a Transmittal Letter will seldom be used for Contractor Deliverables. For Deliverables the Contractor submits to TOMIS, the system will acknowledge receipt after NGS marks the item as received. For all large digital files (greater than 3MB) and for hard copy materials that the Contractor submits outside of TOMIS, (hardcopy data being sent via express mail, regular mail, etc.) the Contractor shall submit a report to TOMIS stating the material submitted and the method of shipment.- Transmittal Letters will continue to be used for items the Government ships to the Contractor. See sample Transmittal Letters in Attachment E.

12.14 SECURITY REQUIREMENTS - The security Certification and Accreditation Package requirement in DOC Clauses CAR 1352.239-73 Security Requirements For Information Technology Resources and security background investigation requirement in CAR 1352.239-74 Security Processing Requirements For Contractors/Subcontractor Personnel For Accessing DOC Information Technology Systems, which are included in the basic contract, shall be submitted to the points of contact identified in Section 13 of the Statement of Work.

13. POINTS OF CONTACT - Send all technical reports, comments, questions, data, etc. to the first POC.

George E. Leigh
Contracts Technical Manager
National Geodetic Survey, NOAA
ATTN: N/NGS; SSMC3, Sta. 8609
1315 East-West Highway
Silver Spring, Maryland 20910
301-713-3167
email: George.Leigh@noaa.gov

Jeffrey Hale
COR
National Geodetic Survey, NOAA
ATTN: N/NGS; SSMC3 Sta. 8753
1315 East-West Highway
Silver Spring, Maryland 20910
(301) 713-3171 ext 132
email: Jeffrey.Hale@noaa.gov

Version 2
February 20, 2007

ATTACHMENT A
AIRPORT GROUND CONTROL SURVEYS

TO
SCOPE OF WORK FOR GROUND SURVEYS

NATIONAL GEODETIC SURVEY
NATIONAL OCEAN SERVICE
NATIONAL OCEANIC & ATMOSPHERIC ADMINISTRATION
U.S. DEPARTMENT OF COMMERCE

ATTACHMENT A – GROUND SURVEYS FOR AIRPORTS

1. ESTABLISHMENT OF PACS AND SACS

Detailed guidance is found in publication “General Specifications for Aeronautical Surveys, Volume I, Establishment of Geodetic Control on Airports”.

2. AIRPORT GROUND SURVEYS OF RUNWAYS, OBSTRUCTIONS, ETC.

Detailed guidance is found in publication “General Specifications for Aeronautical Surveys, Volume III, Airport Ground Surveys”.

3. GROUND PHOTO CONTROL SURVEY

3.1 CONTROL POINTS - Approximately ten (10) ground surveyed, photogrammetric control points may be required at each airport. The control point locations shall be nonlinear and well distributed around the airport at a fixed, non-random, interval. NGS may provide a graphic for each airport with suggested general locations for each pair of control points (5 pairs for a total of approximately ten ground surveyed control points). The required coordinate system is the Universal Transverse Mercator (UTM) in NAD 83. Specify the UTM zone used. CORS & OPUS should be used to position the ground control points.

3.2 DATA FORMAT - Provide an ASCII file for all points with:

Station Name

Northing (UTM; meters, to 2 decimal places)

Easting (UTM; meters, to 2 decimal places)

Orthometric Height (meters, to 2 decimal places; relative to NAVD 88)

Ellipsoid Height (meters, to 2 decimal places)

See Annex 1 “Ground Control Points,” for an example.

3.3 SKETCH - Two types of sketches are required. The first is a sketch of the entire airport area showing all control points with different symbology for new points and for existing control. Secondly, prepare a separate sketch of each control point, showing its immediate vicinity. See Annex 2 “Field Survey Sketch,” for an example. Include a brief description of the point under “Notes” at the bottom of this document. See Attachment R for photo requirements.

3.4 ACCURACY AND DATUMS

A. Horizontal positions shall be determined with an accuracy of 0.3 meters relative to the National Spatial Reference System (NSRS) NAD 83.

B. Orthometric elevations shall be determined with an accuracy of 0.3 meters

relative to the NSRS (NAVD 88).

C. In Alaska and other areas outside the continental United States where NAVD 88 bench marks are not available, the Contractor shall make GPS ties to tidal bench marks within the project area.

ANNEX 1 - Sample Ground Control Coordinates

Airport Name:

Coordinate system:

Zone:

Reference Ellipsoid:

Horizontal and Vertical Datum:

Station Name	Northing	Easting	Ortho. Height	Ellipsoidal Height
P01	2086849.62	3579322.68	115.48	83.34
P02	2086905.37	3583818.97	78.47	46.29
P03	2092134.98	3584776.85	93.59	61.45
P04	2093245.00	3586869.35	97.09	64.94
P05	2089958.84	3591583.70	88.78	56.53
P06	2084575.11	3596417.02	51.81	19.39
P07	2080281.03	3598531.32	12.47	-20.02
P08	2075655.30	3602180.66	3.04	-29.52
P09	2075499.76	3599408.29	11.76	-20.77
P10	2071002.61	3598110.64	63.01	30.49
P11A	2070470.79	3593392.50	40.61	8.13
P13	2081879.33	3591462.22	59.19	26.81
P14A	2080413.30	3585137.48	108.09	75.78

All heights are in Meters

ANNEX 2 - Sample Field Survey Sketch

U.S. DEPARTMENT OF COMMERCE NATIONAL OCEANIC AND ATMOSPHERIC ADMINISTRATION NATIONAL GEODESIC SURVEY		FILE NUMBER GPS 'LES'	DC 5078	PAGE OF
		PHOTO NUMBER 99BP 5938 RATIO		DATE 8-30-00
FIELD SURVEY SKETCH		AIRPORT NAME WALKESHA COUNTY AIRPORT		STATE WI
SUBJECT SS#1(GPS)2000 + SS#2(GPS)2000				
<p>NOTE: SS#1(GPS)2000 is the NE corner of newer concrete sidewalk which abuts the west end of older concrete sidewalk.</p> <p>SS#2(GPS)2000 is the SE corner formed by a N-S concrete sidewalk and an asphalt drive west to a house.</p>				

L52

ANNEX 3 - Sample ASCII Image File (Results of the Geo-referencing)

Results of the geo-referencing of frame imagery shall be reported in an ASCII file, each with 8 columns (Strip ID, Image ID, X, Y, Z, omega, phi, kappa). The file shall report positions in the appropriate UTM coordinates and Zone. The file shall report orthometric heights in meters. Frame orientation elements (Omega, Phi, Kappa) shall be in radians. Columns shall be separated by open spaces. The files shall contain a line of header information and conform to the following examples:

- Airport Name:**
- Coordinate System:**
- Zone:**
- Reference Ellipsoid:**
- Horizontal and Vertical Datum:**

Strip #	Image #	Easting	Northing	Ortho Height	Omega	Phi	Kappa
1	1	3579254.35	2089643.60	3824.12	-.0001358	.0107300	-.8732658
1	2	3580688.07	2087953.67	3823.95	-.0162651	.0005193	-.8841331
1	3	3582126.18	2086260.81	3829.93	-.0404605	.0022521	-.8826661
2	1	3582017.30	2092108.36	3821.09	-.0306452	.0034061	-.8539204
2	2	3583490.60	2090446.64	3833.50	-.0095850	.0067647	-.8527867
2	3	3584965.37	2088806.15	3825.61	-.0219045	-.0030697	-.8461040

Version 2
February 20, 2007

ATTACHMENT B
PROJECT SUBMISSION CHECKLIST

TO
SCOPE OF WORK FOR GROUND SURVEYS

NATIONAL GEODETIC SURVEY
NATIONAL OCEAN SERVICE
NATIONAL OCEANIC & ATMOSPHERIC ADMINISTRATION
U.S. DEPARTMENT OF COMMERCE

EXHIBIT A

SUBMISSION CHECKLIST, GPS PROJECTS
Any or all items may be digital

Project Title: _____
Submitting Agency: _____
Observing Agency: _____
Receiver Type: _____

PACKAGE CONTENTS

<u>Project Report and Attachments</u>	<u>Required For</u>
() NGS approval of proposed project, email/memo	All Projects
() Approved Reconnaissance and Project Sketch	All Projects
() Project Instructions or Contract Specifications	All Projects
() Final Station List	All Projects
() Station Visibility Diagrams	All Projects
() Final Observing Schedule	All Projects
() Observation Logs	All Projects
() Equipment Failure Logs	NGS Projects
() Loop Misclosures	Optional
() Free Horizontal Adjustment with Analysis (NAD83)	All Projects
() Free Horizontal Adjustment with Accuracies	All Projects
() Constrained Horizontal Adjustment (NAD83)	All Projects
() Free Vertical Adjustment (NAVD 88 Heights)	All Projects
() Constrained Vertical Adjustment (NAVD 88 Heights)	All Projects
() Meteorological Instrument Comparison Logs	If Specified
() Photographs or Rubbings of Station Marks	All Projects
() Photographs of Views from Stations	Recommended
() COMPGB Output (Validation program--B/G files)	All Projects
() OBSDES Output (Validation program--B/D-files)	All Projects
() OBSCHK Output (Validation program--B/G-files)	All Projects
() WCHKDESC Output (Validation program--D-file)	All Projects
() NEWCHKOB Output (Validation program--B-file)	All Projects
() ELLACC Output	All Projects
() BBACCUR Output	All Projects
() Project Report	All Projects
() Raw Phase Data (R-files)	All Projects
() Base Line Vectors (G-file)	All Projects
() Project and Station Occupation Data (B-file)	All Projects
() Descriptions or Recovery Notes (D-file)	All Projects
() Serfil	All Projects
() Terrestrial Horizontal Observations (T-file)	If Applicable
() Differential Leveling Observations (L-file)	If Applicable

Comments - Enter on the reverse side of this form.

Version 2
February 20, 2007

ATTACHMENT C
WORLD WIDE WEB SITES

TO
SCOPE OF WORK FOR GROUND SURVEYS

NATIONAL GEODETIC SURVEY
NATIONAL OCEAN SERVICE
NATIONAL OCEANIC & ATMOSPHERIC ADMINISTRATION
U.S. DEPARTMENT OF COMMERCE

ATTACHMENT C

World Wide Web Sites

NGS Home Page can be accessed at: <http://www.ngs.noaa.gov/>

There NGS presents a wealth of information on its data products, software programs, user services, and Scopes of Work, as well as links to other helpful sites on the Web.

NGS Height Modernization Web Site can be accessed at:

<http://www.ngs.noaa.gov/heightmod/>

CORS Data can be accessed at: <http://www.ngs.noaa.gov/CORS/>

Information on the National CORS system, the Cooperative CORS system, and access to CORS and Precise Ephemeris data downloads are available on the NGS web site. Use the “User Friendly CORS” utility to download customized RINEX data sets and IGS ephemeris. The latest coordinate files and other metadata for each CORS site is also available. The “Data Availability” feature can be used to determine if a CORS site is missing data for a particular time period.

USCG Navigation Center GPS Web Site can be accessed at: <http://www.navcen.uscg.gov/>

This site provides information on the status of the GPS constellation and provides NANU message postings and notices for outages at WAAS and DGPS sites.

GPS ANTENNA CALIBRATION Site: <http://www.ngs.noaa.gov/ANTCAL/>

Provides information on which antennas have been calibrated.

PAGE-NT - PAGE-NT is a menu-driven suite of programs used to process GPS data and is suitable for projects requiring the highest accuracy. A User’s Manual, the software, and sample data set can be downloaded from the NGS anonymous ftp server:

ftp ftp.ngs.noaa.gov

login: anonymous

passwd: your complete email address

Once logged on, go to the /pub/pnt6 directory and download all the files using binary transfer mode. The input1 and results1 directory contain the sample data sets.

Follow the setup instructions in the PAGE-NT User’s Manual.

ADJUST - The ADJUST and ADJUST UTILITIES software package can be downloaded from the NGS home page (<http://www.ngs.noaa.gov>) by accessing the “PC Software” link. Check the web page for the latest version of each program. The software performs a least squares adjustment on horizontal, vertical angle, and/or GPS observations. The program comprises six data checking programs in addition to the adjustment software. This software package has numerous options, such as choice of ellipsoid, and includes sample input data. Also available is the source code.

ADJUST UTILITIES - Suite of programs that are used in conjunction with PC program ADJUST. This group of programs includes:

BBACCUR provides a formatted listing of the external and internal accuracies which have been computed by program ADJUST-- sorted in numerical ascending order of external accuracy. Output from program ADJUST, run with accuracies, is used as input.

CLUSTER is used to identify geodetic stations which are common to two data sets with respect to name or a given position tolerance.

ELEVUP creates a bfile which combines the bfile output from the constrained horizontal adjustment with the bfile output from the constrained vertical adjustment. This new bfile contains *80* records with adjusted positions from the horizontal and *86* records with the ellipsoidal heights from the horizontal adjustment and the orthometric heights and geoid heights from the vertical adjustment.

ELLACC computes ellipsoidal height order and class for a project. Output from program ADJUST, run with accuracies, is used as input.

MAKE86 adds *86* records to the bfile. If the existing *80* records contain orthometric heights, these are added to the new *86* records.

MODGEE scales the standard errors assigned to the observations in the gfile. Input is a gfile and the scaling factor.

QQRECORD adds qq records to the Afile (used by program ADJUST) to compute accuracies for all observed lines. Either the gfile (for GPS projects) or the bfile (for classical terrestrial projects) can be used as input.

Data Sheet Utilities -

DSDATA is the Digital Data Sheet extraction program. Extracts individual or groups of data from a DSDATA file. Includes options to extract by Station Identifier, Station Name, Area, and more.

Other Software Programs - Below is a select listing of other software that is currently accessible through the Web. For the full and most recent list of NGS programs, visit the NGS PC Software web page. On-line interactive versions of some of these programs are available in the NGS PC Software Website at: http://www.ngs.noaa.gov/PC_PROD/pc_prod.shtml

COMPGB tests the consistency and compatibility of the Blue Book B file (GPS project and station occupation data) and G file (GPS vector data transfer file).

CR8BB reformats GPS project information to fit the requirements of the National Geodetic Survey data base. The file created, which is called the B-file, contains project information, station information, and survey measurements. The CR8BB software functions independently of the type of GPS receivers used in a project.

CR8SER extracts data from a GPS Blue Book G file to create a station serial number file (serfil) for GPS observations.

WINDESC – latest software to create control point descriptions; see:
http://www.ngs.noaa.gov/PC_PROD/PARTNERS/index.shtml

WDDPROC organizes control point descriptions in accordance with the National Geodetic Survey's description file (D-FILE) format.

DSWIN is Windows-based software for data sheet viewing and extraction. It displays a list of county names as found on your CD-ROM. Click on a county and a list of stations appears. Click on a station from the list and a data sheet appears. You may save the data sheet to a file or print it. The search feature allows for filtering the station list by: Point Radius, Min/Max Box, Station Name, or PID. You can also filter by type of control, such as first-order bench marks only.

GEOID03 (or latest model) Computes geoid height values for the conterminous United States, Alaska, Puerto Rico, Virgin Islands, and Hawaii. Suitable for conversion of NAD 83 GPS ellipsoidal heights into NAVD 88 orthometric heights. See:
<http://www.ngs.noaa.gov/GEOID/>

HTDP is a horizontal time-dependent positioning software program which allows users to predict horizontal displacements and/or velocities at locations throughout the United States. This software also enables users to update geodetic coordinates and/or observations from one date to another.

INVERSE3D is the three dimensional version of program INVERSE, and is the tool for computing not just the geodetic azimuth and ellipsoidal distance, but also the mark-to-mark distance, the ellipsoid height difference, the dx, dy, dz (differential X, Y, Z used to express GPS vectors), and the dn, de, du (differential north, east, up using the FROM station as the origin of the new coordinate system). The program requires geodetic coordinates as input, expressed as either: 1) latitude and longitude in degrees, minutes, and seconds or decimal degrees along with the ellipsoid heights for both stations, or 2) rectangular coordinates (X, Y, Z in the Conventional Terrestrial Reference System) for each station. The program works exclusively on the GRS80 ellipsoid and the units are meters. Both types of coordinates may be used in the same computation. The program reads input geodetic positions as positive north and positive west.

LOOP determines the loop misclosures of GPS base lines using the delta x, delta y, delta z vector components computed from a group of observing sessions.

Version 2
February 20, 2007

ATTACHMENT D
STATION SELECTION GUIDLINES

TO
SCOPE OF WORK FOR GROUND SURVEYS

NATIONAL GEODETIC SURVEY
NATIONAL OCEAN SERVICE
NATIONAL OCEANIC & ATMOSPHERIC ADMINISTRATION
U.S. DEPARTMENT OF COMMERCE

ATTACHMENT D - STATION SELECTION GUIDELINES

Generally, station selection shall be based on the following criteria. Specific requirements are project dependent and the following criteria will be supplemented by those project-specific requirements.

The following is a list of considerations for each station in FBN. The intent is to ensure that station monuments will be locally stable and remain usable indefinitely. Each of these considerations is important.

Adequate GPS satellite visibility (unrestricted at 15 degrees and higher above the horizon). Minor obstructions may be acceptable, but must be depicted on the Visibility Obstruction Diagram,

Accessible by vehicle (two-wheel drive preferred),

Stability; bedrock mark being most preferred. (See STABILITY),

Permanency,

Ease of recovery,

Avoid known multi-path sources,

Appropriate geographic location and spacing,

Location allows efficient use by surveying community,

Accessible by public. (See ACCESSIBILITY),

No known potential conflict with future development,

Open area for possible aerial-photo paneling,

Avoid electronic interference where possible.

STABILITY

Station monument stability is often difficult to assess in the field with limited resources. For existing NSRS station monumentation, the NGS data base contains stability qualifiers which were assigned for the majority of marks when they were set. For FBN stations, existing NSRS stations must have a stability Quality Code of "C" or better. Quality Codes A and B are preferred. New monuments will have a stability Quality Code of B or better.

Quality Codes are as follow:

Quality Code A - most reliable; are expected to hold a precise elevation. Examples: rock outcrops; rock ledges; rock cuts; bedrock; massive structures with deep foundations; large structures with foundations on bedrock; or sleeved deep settings (10 ft or more) with galvanized steel pipe or galvanized steel, stainless steel, or aluminum rods.

Quality Code B - will probably hold a precise elevation. Examples: unsleeved deep settings (10 ft or more) with galvanized steel pipe or galvanized steel, stainless steel, or aluminum rods; massive structures other than those listed under Quality Code A; massive retaining walls; abutments and piers of large bridges or tunnels; unspecified rods or pipe in a sleeve less than 10 ft; or sleeved copper-clad steel rods.

Quality Code C - may hold precise elevation, but subject to ground movement. Examples: metal rods with base plates less than 10 ft deep; concrete posts (3 ft or more deep); unspecified rods or pipe more than 10 ft deep; large boulders; retaining walls for culverts or small bridges; footings or foundation walls of small to medium-size structures; or foundations such as landings, platforms, or steps. (See Quality Code C Exception, below.)

Quality Code D - of questionable stability. Examples: generally, objects of unknown character; shallow set rods or pipe (less than 10 ft); light structures; pavements such as street, curbs, or aprons; piles and poles such as spikes in utility poles; masses of concrete; or concrete posts less than 3 ft deep.

Quality Code C Exception - when selecting FBN stations, only Quality Codes A and B are recommended. However, concrete posts may be selected with a C stability if the mark is deemed stable from review of historical releveling, soil type, and frost depth. Final selection is subjective, and is based on local knowledge of soil and frost heave, plus knowledge of how well the mark has held its horizontal and vertical positions over the years.

ACCESSIBILITY

Accessible public property should be utilized where feasible. If the station is located on private property, permission must be obtained from the land owner for station accessibility. Include the name, address, and, if public ownership, the telephone number of the responsible party. Do not include telephone numbers of private property owners.

Version 2
February 20, 2007

ATTACHMENT E
SAMPLE TRANSMITTAL LETTER
(BLANK AND FILLED-IN)

TO
SCOPE OF WORK FOR GROUND SURVEYS

NATIONAL GEODETIC SURVEY
NATIONAL OCEAN SERVICE
NATIONAL OCEANIC & ATMOSPHERIC ADMINISTRATION
U.S. DEPARTMENT OF COMMERCE

LETTER TRANSMITTING DATA

DATA AS LISTED BELOW WERE FORWARDED TO YOU BY (Check)

- | | |
|--|-----------------------------------|
| <input type="checkbox"/> ORDINARY MAIL | <input type="checkbox"/> AIR MAIL |
| <input type="checkbox"/> REGISTERED MAIL | <input type="checkbox"/> EXPRESS |
| <input type="checkbox"/> GBL (Give number) _____ | |

TO:

[]

[]

DATE FORWARDED

NUMBER OF PACKAGES

NOTE: A separate transmittal letter is to be used for each type of data, as tidal data, seismology, geomagnetism, etc. State the number of packages and include an executed copy of the transmittal letter in each package. In addition the original and one copy of the letter should be sent under separate cover. The copy will be returned as a receipt. This form should not be used for correspondence or transmitting accounting documents.

FROM: (Signature)

RECEIVED THE ABOVE
(Name, Division, Date)

Return receipted copy to:

[]

[]

Reset

REFERENCE NO.

LETTER TRANSMITTING DATA

DATA AS LISTED BELOW WERE FORWARDED TO YOU BY
(Check):

- ORDINARY MAIL
- AIR MAIL
- REGISTERED MAIL
- EXPRESS
- GBL (Give number) _____

DATE FORWARDED

NUMBER OF PACKAGES

TO:

┌	┐
└	┘

NOTE: A separate transmittal letter is to be used for each type of data, as tidal data, seismology, geomagnetism, etc. State the number of packages and include an executed copy of the transmittal letter in each package. In addition the original and one copy of the letter should be sent under separate cover. The copy will be returned as a receipt. This form should not be used for correspondence or transmitting accounting documents.

FROM: (Signature)

RECEIVED THE ABOVE
(Name, Company, Date)

Return receipted copy to:

┌	┐
└	┘

Version 2
February 20, 2007

ATTACHMENT F
EXPLANATIONS OF GOVERNMENT SUPPLIED MATERIALS

TO
SCOPE OF WORK FOR GROUND SURVEYS

NATIONAL GEODETIC SURVEY
NATIONAL OCEAN SERVICE
NATIONAL OCEANIC & ATMOSPHERIC ADMINISTRATION
U.S. DEPARTMENT OF COMMERCE

ATTACHMENT F

EXPLANATIONS OF GOVERNMENT SUPPLIED MATERIALS

A.1 TRANSMITTAL LETTER

A letter containing a list of all items shipped to the contractor for a particular survey, the date the items were shipped, and the name and address of the individual who shipped them. The contractor is responsible for verifying the receipt of all items listed and returning a signed copy of the transmittal letter to the address listed. See Attachment E.

A.2 PROJECT INSTRUCTIONS FOR GROUND SURVEYS

A set of instructions which is specific to a particular survey. The Project Instructions will typically contain the following sections:

- A. General
 - i. Project Name
 - ii. Geographic Limits
 - iii. Project Identification Number
 - iv. Size of project/ number and type of points
 - v. Point of Contact
- B. Purpose
- C. Project Plan
- D. Data Acquisition
 - i. Equipment
 - ii. Observations
- E. Data Processing
- F. Data Submission

A.3. BRASS DISKS

NGS will supply standard, pre-stamped disks with the NGS logo, if required. These disks shall be used by the contractor for NGS projects only. The Contractor should notify NGS of the approximate quantity required and shall return all unused disks at the end of the project.

A.4. LOGO CAPS

NGS will supply standard, pre-stamped NGS logo caps with the NGS name, if required. These logo caps shall be used by the contractor for NGS projects only. The Contractor should notify NGS of the approximate quantity required and return all unused logo caps at the end of the project.

**ATTACHMENT G
STATUS REPORT FORMAT**

TO
SCOPE OF WORK FOR GROUND SURVEYS

NATIONAL GEODETIC SURVEY
NATIONAL OCEAN SERVICE
NATIONAL OCEANIC & ATMOSPHERIC ADMINISTRATION
U.S. DEPARTMENT OF COMMERCE

TABLE OF CONTENTS

ATTACHMENT G: <u>STATUS REPORT FORMAT</u>	PAGE
1. GENERAL.....	3
2. DELIVERABLES SUBMITTED.....	3
3. FUTURE PLANS.....	3
4. COMMENTS.....	3

ATTACHMENT G: STATUS REPORT FORMAT

1. GENERAL

1.1 Format - The Prime Contractor shall submit project status reports via **TOMIS** every Monday by 2:00 PM Eastern Time, from the date of a Task Order award until the work is complete and accepted by NGS. **These reports shall show the status of each Deliverable** in order to help track the progress. A suggested format is shown below (the percent complete and date are required).

Submit the **status report to TOMIS as** an attachment **in MS Word, MS Excel, or PDF format.** The table boxes shown below are not required, but ensure that the information is in columns so that it is more readable.

Prime Contractor Firm

Name: _____

Sub-Contractor(s) Firm Name: _____

Project ID & Location	TX0401/South TX	CA0401/SF Bay Area
Dates:	(sample)	(sample)
Date Task Order Awarded		
Date Project Due		

Project ID	TX0401 (Approx. % Complete)	Date Complete or Planned Complete	CA0401 (Approx. % Complete)	Date Complete or Planned Complete
Project Deliverables				
Deliverable #1	100%	1 MAR 05		
Deliverable #2	75%	1 APR 05		
Deliverable #3		1 MAY 05		
Deliverable #4		1 NOV 05		
Etc.		1 DEC 05		
Overall Completeness		15 DEC 05		

1.2 Sample percentages and dates filled in above.

1.3 Include the above information for each project underway; add 2 columns for each project.

1.4 Flag entries that have been changed from the previous week.

2. DELIVERABLES SUBMITTED - List deliverables submitted

3. FUTURE PLANS - Briefly state plans for the coming week.

4. COMMENTS - Include comments/unusual circumstances/approved modifications from this SOW or Project Instructions.

ATTACHMENT H
TECHNICAL PROPOSAL CONTENTS

TO
SCOPE OF WORK FOR GROUND SURVEYS

NATIONAL GEODETIC SURVEY
NATIONAL OCEAN SERVICE
NATIONAL OCEANIC & ATMOSPHERIC ADMINISTRATION
U.S. DEPARTMENT OF COMMERCE

TABLE OF CONTENTS

ATTACHMENT H: <u>TECHNICAL PROPOSAL CONTENTS</u>	PAGE
1. GENERAL.....	3
2. INCLUDED INFORMATION.....	3
2.1 PRIME AND SUBS.....	3
2.2 TIME LINE.....	3
2.3 PROJECT LIMITS.....	3
2.4 ACCURACY.....	3
2.5 TIDE COORDINATION.....	3
2.6 GROUND CONTROL.....	3
2.7 CALIBRATIONS.....	3
2.8 GROUND BASE STATIONS.....	3
2.9 QUALITY CONTROL (QC).....	3
2.10 REPORTS.....	3
2.11 PROPOSED INSTRUMENTATION.....	3
2.12 ADDRESS.....	4
2.13 TOMIS DELIVERABLE TRACKING LOG	4

H: TECHNICAL PROPOSAL CONTENTS

1. GENERAL - Technical Proposals shall contain at least the sections and information listed below. The Technical Proposals shall not contain the SOW or the Project Instructions, but shall contain information about the methodologies and equipment selected by the contractor and reasoning/justification for these methods. **In addition, the TOMIS Deliverable Tracking Log shall be included.**

2. INCLUDED INFORMATION

2.1 PRIME AND SUBS - State which firm(s) will perform which portions of the project.

2.2 TIME LINE - Provide rough time-line.

2.3 PROJECT LIMITS - A brief statement showing that the contractor understands the Project area.

2.4 ACCURACY - A brief statement on the accuracy requirements and how they will be achieved.

2.5 TIDE COORDINATION - A brief statement on what tidal coordination is required and who will compute the predicted tidal time windows. Mention if the installation of tide gauges are required, and if so, type, location, etc., and discuss tidal data collection and processing. Mention if tide gauges and weather will need to be monitored and how this will be done.

2.6 GROUND CONTROL - Provide a map showing locations of all ground control points using different symbology for existing control, and new control. State the total number of points and justify why that number is correct for the project. Discuss how these points will be marked and how they will be positioned and/or checked. State if CORS and OPUS will be used, and why or why not. Note: approximate locations are acceptable. Also, state what type of survey will be used to complete the project (leveling, GPS, etc...).

2.7 CALIBRATIONS - Discuss equipment calibrations.

2.8 GROUND BASE STATIONS - Provide map showing locations of ground base stations (approximate locations acceptable), if required. State how they will be positioned and/or checked. State how long data will be collected and how it will be processed. State the distance from each base station to the farthest points in the project area. Justify the number, location, and type of base stations proposed. Discuss use of CORS and interpolation, if proposed.

2.9 QUALITY CONTROL (QC) - State how all work will be reviewed and how the prime will oversee their sub-contractors.

2.10 REPORTS - List the reports that will be submitted.

2.11 PROPOSED INSTRUMENTATION - (instruments, rods, etc. including model, serial

numbers and copies of rod calibration certificates.

2.12 ADDRESS - State the NGS address where all data and invoices will be sent.

2.13 TOMIS DELIVERABLE TRACKING LOG – In the format specified in the Project Instructions.

Version 9b
February 20, 2007

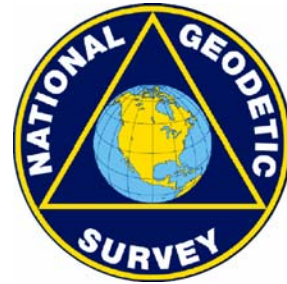
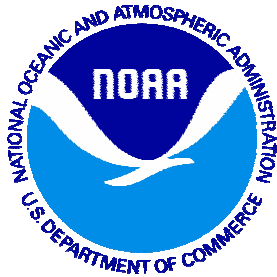

ATTACHMENT I GEODETIC LEVELING SURVEYS

for

**U.S. DEPARTMENT OF COMMERCE
NATIONAL OCEANIC AND ATMOSPHERIC ADMINISTRATION
NATIONAL OCEAN SERVICE
NATIONAL GEODETIC SURVEY**



TABLE OF CONTENTS

SUBJECT	SECTION

INTRODUCTION	1
ADMINISTRATION	2
GOVERNMENT SUPPLIED MATERIALS	3
REFERENCE SYSTEMS	4
REFERENCES AND GLOSSARY	5
QUALITY CONTROL	6
DATA FORMATS	7
DATA MEDIUM AND FILE NAMING CONVENTION	8
SURVEY METHODOLOGY	9
SURVEY WORK	10
FINAL PROJECT REPORT	11
DELIVERABLES	12
POINTS OF CONTACT	13

ATTACHMENT I

GEODETIC LEVELING SURVEYS

1. INTRODUCTION

This Scope of Work (SOW) lists requirements for geodetic leveling surveys. Geodetic leveling is used to determine accurate orthometric height differences and extend vertical control networks. This work is administered by the National Geodetic Survey (NGS), National Ocean Service (NOS), National Oceanic and Atmospheric Administration (NOAA). Note, if Global Positioning System (GPS) surveys are required, they will be specified in separate Project Instructions and details provided in a separate SOW.

2. ADMINISTRATION

2.1 PRECEDENCE - This SOW provides general standards and specifications. In addition, the Contractor will be issued a set of Project Instructions for each survey. The Project Instructions will take precedence over this SOW since they provide detailed and often unique information. The requirements for reporting deviations, unusual circumstances, etc. described in the following paragraphs, apply to the SOW and to the Project Instructions.

2.2 CONVENTIONS - The following conventions have been adopted for these project specifications. The verb “shall” means that compliance is required. The verb “should” denotes a strong recommendation. The contraction N/A means not applicable. The term “position” means horizontal position (latitude and longitude) unless specified otherwise. The term “elevation” means the distance of a point above a specified datum, measured along the direction of gravity. The term “vertical” refers to the direction in which the force of gravity acts. The term “height” means the distance, measured along a perpendicular, between a point and a datum. See SOW Section 4. The term “Difference in Elevation” (DE) is defined as the DE between two monuments. The term “Section” means the leveling between two immediately adjacent monuments (no monument may be missed in the return run). The term “Set-up” refers to the adjustment of a leveling instrument so that it is in proper position at a point from which backsight and foresight observations are to be made. The term “Run” or “Running” is the transfer of the DE from the beginning monument to the turning point for the initial set-up and transferring the DE from the back turning point to the forward turning point for each following set-up, until the section is closed on the ending monument. The term “loop” is a continuous line of levels, a series of lines of levels, or a combination of lines or parts of lines of levels that, together with a continuous series of measured differences of elevation, forms a loop back to the starting point. The term “loop misclosure” is the amount by which two values for the elevation of the same bench mark, derived by different surveys, by the same survey made along two different routes, or by independent observations, fail to exactly equal each other.. The term “monument” is generally, any material, object, or

collection of objects which indicates the location, on the ground, of a survey station or corner. Please see Attachment W for commonly used acronyms in this Scope of Work.

2.3 GENERAL REQUIREMENTS - The services to be rendered by the Contractor include all the work described in this SOW and the Project Instructions. Details not specifically described in the SOW or Project Instructions are nevertheless a firm requirement if they can be identified as an item or items commonly associated with professional grade work of a comparative nature.

2.4 MODIFICATIONS - All requests for modifications shall be submitted by the Contractor in writing to the Contracting Officer (CO) prior to making the modifications. No modifications may be made without prior written approval from the CO. Send a copy of these requests to the Points of Contact (POCs) listed in SOW Section 13.

2.5 UNUSUAL CIRCUMSTANCES - After award, the Contractor shall notify the CO and the NGS POCs of any unusual circumstances that occur during the performance of this SOW or Project Instructions, which may affect the deliverables or their quality (see SOW Sections 6 and 7). Especially note any deviation from this SOW or Project Instructions. This shall be done as soon as possible in case modifications need to be made.

2.6 ORIGINAL DATA - Observation logs and other original records generated during this project are legal records, which will be retained for data accountability and stored in the National Archives. These logs shall be original, legible, neat, clear, and fully completed in indelible black ink. Original data shall be saved, unmodified, whether in hand-written or computer-recorded form. All available spaces on the recording forms should be completed. In the original records (paper or digital), *nothing is to be erased or obliterated*. If a mistake is made on a form, draw a single line ~~through the mistake~~ and write the correction above or to the side. The person making the change shall initial all corrections. If space is too limited to permit a field correction, restart with a new log sheet, *do not recopy the form in the field or the office* in order to make a clean copy. An explanatory note should be made for all corrections to the original recorded figures. It is essential that all recorded information be neat and legible. All editing of computer recorded data shall be done on a copy of the original. Always submit the original version of the data, not a hand-made copy, a photocopy, nor a digital copy. NOAA Form 77-82 (Geodetic Leveling Backup Sheet) shall be completed in its entirety. A digital copy of this form will be provided on CD. There is a section for remarks on the backup sheets, if that is not enough room write "see back of sheet" in the remarks section and continue on the back of the backup sheet. If a section has to be restarted note the reason on the backup sheet that you started with and then use a new backup sheet for the section. Both sheets shall be submitted with the project. Any changes shall carry the initials of the individual making the change.

2.7 COMPLIANCE REQUIREMENTS – The contractor shall comply with all Federal, State, Commonwealth and local requirements.

3. GOVERNMENT SUPPLIED MATERIALS

The following items will be supplied, if applicable:

3.1 TRANSMITTAL LETTER (See Attachment E),

3.2 PROJECT INSTRUCTIONS,

3.3 EXISTING SURVEY CONTROL - Most control is accessible from the NGS web site <http://www.ngs.noaa.gov> by selecting “data sheets.” Required and suggested connections to existing control, including data from other agencies, will be listed in the Project Instructions.

3.4 BRASS DISKS - Disks with factory standard NGS inscription.

3.5 ROD MARK SUPPLIES.

- A. Logo Caps - Caps for 3D rod marks with standard NGS inscription
- B. 4 foot Stainless Steel Threaded Rods
- C. Connector Studs
- D. Witness Posts

3.6 CD – Containing a digital copy of the NOAA Manual NOS NGS 3 “Geodetic Leveling”.

See Attachment F for explanations of items listed above.

4. REFERENCE SYSTEMS

Use the following Reference Systems:

4.1 HORIZONTAL REFERENCE - The North American Datum of 1983 and year of the latest observations which is abbreviated NAD83 (currently 2002 for Puerto Rico). Note: the year of observations is on the NGS Data Sheet next to the latitude and longitude.

4.2 VERTICAL REFERENCE - Orthometric heights – NAVD 88 for the Conterminous US and PRVD 02 for Puerto Rico. Ellipsoidal heights are referenced to NAD 83 (GRS 80).

4.3 REFERENCE SYSTEM - National Spatial Reference System (NSRS). For information on NSRS see http://www.ngs.noaa.gov/INFO/OnePagers/One-Page_NSRs.pdf and “Development of the National Spatial Reference System” http://www.ngs.noaa.gov/PUBS_LIB/develop_NSRs.html

The surveys shall be tied to the NGS vertical network. Specific tie requirements will be supplied in the Project Instructions (e.g. ties to NOAA tidal bench marks, U.S. Geological Survey (USGS) marks and/or U.S. Army Corps of Engineers (USACE) marks).

4.4 GEOID MODEL - GEOID 99, or later; use the most current version for Puerto Rico projects. GEOID 03 is available for the Conterminous United States only. For GEOID information see: <http://www.ngs.noaa.gov/GEOID/GEOID99/index.html>

For explanations of many of the terms in SOW Section 4, see:
<http://www.ngs.noaa.gov/faq.shtml>

5. REFERENCES AND GLOSSARY

REFERENCES - Note, the Contractor SHALL become thoroughly familiar with following references:

1. FGCS, “*Specifications and Procedures to Incorporate Electronic Digital/Bar-Code Leveling Systems.*” Available on-line at:
http://www.ngs.noaa.gov/FGCS/tech_pub/Fgcsvert.v40.specs.pdf.
2. FGCC, *Standards and Specifications for Geodetic Control Networks*, 1984.
Available on-line at: http://www.ngs.noaa.gov/FGCS/tech_pub/
3. NOAA Manual NOS NGS 3, “*Geodetic Leveling*,” C. Schomaker and R. M. Berry (not available on-line). A digital copy will be provided.
4. NOAA Manual NOS NGS 1 “*Geodetic Bench Marks.*” Available on-line at:
http://www.ngs.noaa.gov/PUBS_LIB/GeodeticBMs.pdf
5. FGCC, “*Input Formats and Specifications of the National Geodetic Survey Data Base, Volume II Vertical Control*” commonly called the “Blue Book.” Available on-line at: <http://www.ngs.noaa.gov/FGCS/BlueBook/>
6. NGS, “*Geodetic Glossary*”, 1986 (not available on-line). For a printed copy contact the NGS Information Center at (301) 713-3242, or e-mail:
info_center@ngs.noaa.gov.
7. D. Doyle, “*Development of the National Spatial Reference System.*” Available on-line at: http://www.ngs.noaa.gov/PUBS_LIB/develop_NSRS.html
8. *Digital Leveling* by Orlando Murray (not available on-line). For a printed copy contact the NGS POC’s in Section 13.
9. *Procedure’s for recording Field Data for Leice DNA 03 Bar Code Level Instrument* by Ronnie Taylor (not available on-line). For a printed copy contact the NGS POC’s in Section 13.
10. *Control Leveling*, by Charles T. Whalen. Available on-line at:
http://www.ngs.noaa.gov/PUBS_LIB/TRNOS73NGS8.pdf

6. QUALITY CONTROL

The Contractor is responsible for the quality control of all data. The Contractor shall check all data to ensure that they are complete, reliable, and accurate. The Contractor's personnel shall become thoroughly familiar with the SOW and its Attachments; the Project Instructions; the definitions of surveying terms; and with the material covered in the other references and publications, as required. See SOW Section 5 for a list of References.

QUALITY CONTROL PLAN - Prior to beginning survey work, the Contractor shall submit a written Quality Control Plan covering all work, to include at least the following requirements: a check of all manual computations (must include check marks and initials of the individual doing the computations and the individual checking the computation), a check of all manual data computer entries, a check of file formats, and a check of all reports and data submitted. The contractor shall also discuss how data will be backed-up and how it will be ensured that original data are not modified. See SOW Section 12, Deliverables.

Comments on quality control and a copy of the Quality Control Plan shall be included in the Final Project Report.

7. DATA FORMATS

7.1 ORIGINAL DATA - Original, raw digital data shall be submitted and the formats shall be documented in the Project Report. Original paper records shall also be submitted, see SOW Section 2.6.

7.2 FINAL DATA - Final project data shall be submitted in Blue Book format. All sketches, photos, project adjustments, reports, etc. shall be both paper and digital (MS Word format).

8. DATA MEDIUM AND FILE NAMING CONVENTION – All data, including photographs and reports shall be submitted on CD-ROM or DVD, with the photographs on a separate disk. Other data mediums may be acceptable with prior approval from NGS. All level lines will have an L accession number, project title, and line name assigned by NGS. Data files and description files shall have the same name with the extension determining the file type.

9. SURVEY METHODOLOGY - Differential leveling survey methodology, procedures, and equipment shall be used for the work specified in this SOW and the Project Instructions.

10. SURVEY WORK

10.1 PURPOSE - Geodetic leveling extends the vertical network. These surveys shall be tied to NSRS with PRVD 02 as its elevation reference. This vertical system provides Puerto

Rico a common, consistent set of real-time elevations. This vertical network can help provide:

- A. Improved aircraft navigational aids and approach and landing procedures,
- B. Advanced surface transportation control and monitoring,
- C. Highly efficient fertilizer and pesticide spreading, resulting in reduced run-off water pollution,
- D. More accurate modeling of storm surge and pollution trajectories,
- E. Increased accuracy for improved resource management decision-making,
- F. Improved disaster preparedness and earthquake detection,
- G. Advanced enhancement of remote sensing applications (e.g. Light Detection and Ranging (LIDAR), photogrammetry etc.),
- H. Municipalities and communities control to further densify the network,
- I. An elevation model and survey points for Geographic Information System (GIS) use,
- J. Technological transfer to have contractors that can provide precision leveling support in Puerto Rico,
- K. FEMA and USACE a more accurate vertical (height) foundation for their mapping and survey projects.

10.2 PROJECT PHASES - The project may be divided into two phases.

A. Phase One may include:

- Record research;
- Mark Recovery;
- Planning;
- Reconnaissance;
- Preparation of Survey Plan;
- Preparation of Quality Control Plan;

B. Phase Two may include:

- Mark setting (concrete marks, drill hole marks, and/or deep rod marks)
Note: Concrete Post Marks shall be set a minimal of 14 days prior to leveling, all other marks, including deep rod marks shall be set a minimal of 2 days (48 hours) prior to leveling
- Data collection;

Note: Reruns shall be completed as soon as possible after it is determined there is a mis-closed section. Reruns shall not wait until the main leveling is completed.

Data processing;

Data analysis;

Data adjustment;

Data submittal in specified formats;

Preparing reports;

If required by NGS, the contractor(s) will be issued a new task order to complete the following:

Writing manuals and other training aids explaining the work;

Providing training on how to accomplish the work;

Note: NGS may provide training in mark setting, leveling procedures, and data processing.

10.3 RECONNAISSANCE - Reconnaissance shall be performed with guidance from material in Reference 3, "*Geodetic Leveling.*"

A. CONTROL STATIONS - All first, second, and third-order bench marks in or near the project area shall be considered for inclusion in this project. See Project Instructions for specific requirements and Attachment B.

B. DATABASE SEARCH:

1. VERTICAL MARKS - The NGS database shall be searched for all vertical marks (geodetic bench marks) in or near the project area using the NGS Web site at: <http://www.ngs.noaa.gov/cgi-bin/datasheet.prl>.
2. TIDAL BENCH MARKS – If required by the Project Instructions. Many tidal bench marks currently in use can be found at: http://tidesandcurrents.noaa.gov/station_retrieve.shtml?type=Bench+Mark+Data+Sheets. The Project Instructions will contain information on additional tidal bench marks, if required.
3. HIGH ACCURACY REFERENCE NETWORK (HARN) STATIONS - Search the NGS database for all HARN (A and B-order horizontal accuracy) stations. This leveling project should include as many of these stations as possible. Special attention should be paid to including HARN stations located at airports and labeled Primary Airport Control Station (PACS) and Secondary Airport Control Station (SACS). In the Technical Proposal state the conditions for tying to each HARN and the recommendation of the contractor as to the feasibility of that tie. See Attachment H for a complete listing of what should be included in the Technical Proposal.

4. **MARK RECOVERY** - The contractor shall attempt to recover all marks required by this SOW and the Project Instructions, including bench marks, Tidal Bench Marks, first or second order horizontal stations, CORS (Continuously Operating Reference Station) bench marks, and HARN stations along or within a described distance of the level line. Previously unknown marks found during the survey shall also be recovered. See Attachment N for diagrams of NOAA survey disks. The recovery of a control station includes a physical visit to the station to determine its condition, usability, etc. and the preparation of a digital recovery note in NGS format. The recovery notes could vary from one sentence to three paragraphs; see Attachment S. Station descriptions and recovery notes shall be submitted in computer-readable form using WINDESC or WDDPROC software. The WDDPROC software is available on-line at: http://www.ngs.noaa.gov/PC_PROD/DDPROC4.XX/ddproc.index.html The WINDESC software is available on-line at: http://www.ngs.noaa.gov/PC_PROD/PARTNERS/index.shtml (The basic usage instructions are built into WINDESC. You simply go under the HELP menu when you run WINDESC.).
 5. **POSITION** - The Contractor shall obtain at least a pseudo-range GPS position for all marks recovered and/or set. Include this position in the text of recovery notes and descriptions. Data format: DDD MM SS.ss. Upon returning to the station, the contractor shall use the description to find the station and not rely strictly on GPS position.
 6. **MARKS OF OTHER ORGANIZATIONS** - In addition, the Project Instructions may require the recovery and/or use of marks from other organizations (e.g., USGS, USACE etc.) that are not in the NGS database.
- C. **GPS VISIBILITY DIAGRAM** - For all marks recovered, established and used, the contractor shall prepare a GPS visibility obstruction diagram using the form found at: <http://www.ngs.noaa.gov/PROJECTS/FBN/> (click on Forms, then click on Visibility Obstruction Diagram).
- D. **DIGITAL PHOTOGRAPHS** - The contractor shall take digital photographs of all marks recovered in the project as per Attachment R.
- E. **PROPOSED NEW STATION SITES** - The contractor shall propose sites for new bench marks as necessary and propose the type of mark to be set, see SOW Section 10.4. Preliminary descriptions shall be prepared for them as well as visibility diagrams. To the extent possible and practical, station sites should be selected to be permanent, accessible, stable, and have as clear sky visibility, see Attachment D, "Station Site Selection Guidelines". Take two photographs of proposed sites, one showing the ground in the area of the

proposed mark and photo two showing the nearest satellite obstruction (or identifying feature if no obstructions).

10.4 SURVEY PLAN - After completing Phase One (reconnaissance, etc.) and prior to mark setting or observations, the contractor shall submit a Survey Plan. NGS will review the Plan as soon as possible, and will send the contractor written comments and/or approval. The contractor shall not begin mark setting or observations until the Plan is approved. The Plan shall include at least the following sections:

- A. Text with summary of survey planning;
- B. Requests for deviations from the SOW and Project Instructions, if any;
- C. Station table (see details below);
- D. Digital station recovery notes (existing stations);
- E. Digital preliminary station descriptions (new stations);
- F. GPS satellite visibility diagrams;
- G. Project Area Sketch, to scale (include old and proposed new station locations each with different symbology);
- H. Digital photographs;
- I. Proposed instrumentation (instruments, rods, etc. including model, serial numbers and copies of rod calibration certificates, note: instrument type and rod shall be identified in the Technical Proposal by the Contractor);
- J. Proposed Data collection and processing software;
- K. Detailed leveling observation plan;

The Station Table shall include: the station designation (name), NGS Permanent Identifier (PID) provided by NGS, type (bench mark, etc.), establishing agency, order, stability (See Attachment D), condition at recovery, and comments/recommendations. Include proposed name and monument type of any proposed stations to be set. The series of designations will be provided by NGS in the Project Instructions. For existing stations, the name and PID shall be used exactly as listed in the NGS database, and shall be this way in all survey records.

When NGS has approved the Survey Plan, an L accession number, project title, line title, designations, and a set of Station Serial Numbers (SSNs) will be assigned by NGS for each task order.

10.5 MARK SETTING - After the Survey Plan is approved by NGS, the Contractor may begin fieldwork. Marks shall be set in accordance with the approved Survey Plan and to NGS specifications for type, length, material, stability, and stamping outlined in “*Geodetic Bench Marks*” and Attachments T, U, and V. NGS will inspect the mark setting.

10.6 BENCH MARK PLOTS - The location of all marks used in the survey shall be plotted on standard USGS 7.5 minute topographic maps and each mark shall be plotted with a circle, dot and leader to the SSN.

10.7 GEODETIC LEVELING PROCEDURES - Double-run leveling (two acceptable level runs in opposite directions) preferably at different times of the day (run one direction in the

morning and the opposite direction in the afternoon or one direction one day and the opposite direction on the second day and alternate the direction of the runs. For example, if you run all day in the forward direction on the first day, the second day you would run everything in the backward (opposite) direction. Then on the third day you would run in the backward direction and the fourth day run in the forward (opposite) direction. This will allow for different atmospheric conditions on most runs. This will be conducted using First-Order, Class II specifications as described in Reference A, “*Standards and Specifications for Geodetic Control Networks.*” All equipment shall meet first-order requirements, be in excellent condition, be properly handled and cared for, and be recently calibrated. If digital bar-code leveling systems are to be used, the model shall have been previously evaluated by the Federal Geodetic Control Subcommittee (FGCS). These systems include the Leica NA3003, Leica DNA03, Topcon DL101, Trimble DiNi 12, Zeiss DiNi 10, DiNi 11 and DiNi 12. All the above systems shall use single-piece 3-meter invar rods and rod struts. Rod calibration certificates are required. Use of all hardware and software shall be approved by NGS prior to performing any leveling. Reference 3, “*Geodetic Leveling*”, describes the required methods and procedures including: use of instruments, rods, turning pins, how to perform a C-shot (collimation test/peg test), requirements for lengths of sights and number of setups, etc. Reference 1, “*Specifications and Procedures to Incorporate Electronic Digital/Bar-Code Leveling Systems*” contains information on these type systems.

SET UPS - An even number of set-ups is required.

SPUR LINES - Existing marks, which were selected and approved in the Survey Plan, shall be incorporated into the level line. Spur lines may be permitted in consultation with the NGS COR. All spur lines shall be double run and no monument may be missed in the return run. The requirements for the length of spur lines will be listed in the Project Instructions.

10.8 LEVEL DATA PROCESSING - All level lines shall be checked to ensure that the standards in Reference 1 are met. Lines not meeting those standards shall be rerun as soon as possible after the misclosure is found.

10.9 LEVEL DATA ANALYSIS - Analysis will include loop closures, verifying check connection with existing leveling and concurrent leveling (New-Old computations and loop closures shall be included in the final report).

10.10 ADJUSTMENT - No network adjustment is required for submission; however, it is recommended that the contractor perform their own least squares network adjustment to ensure the integrity of the data and report the results.

10.11 LEVEL DATA SUBMITTAL - Final project data shall be submitted in the “Blue Book” format. All sketches, photos, project adjustments, reports, etc. shall be submitted on both paper and digitally (provide text documents in MS Word format). Submit all original data records (paper and digital) marked “ORIGINAL”, see SOW Sections 2.7, 7.1, 12.8, and 12.10.

10.12 MANUALS AND TRAINING - If required by the Project Instructions the contractor shall produce manuals and other training aids (such as Power Point presentations) explaining portions of, or the entire geodetic leveling process. In addition, the contractor may be required to conduct training courses using the above materials.

11. FINAL PROJECT REPORT

The Final Project Report shall contain at least the sections below. See Attachment K for a sample Final Report for a leveling project.

- A. An overview discussion of all required work, including at least: planning, reconnaissance, mark recovery, mark setting, data collection, data processing, data error analysis, New-Old, and loop closures. This discussion shall include a summary of the results, problems encountered, conditions affecting progress, and any unusual circumstances. Include comments on any deviations from the Survey Plan, Project Instructions, or this SOW (include copies of written approvals or e-mail approvals for any deviation from the SOW or Project Instructions).
- B. A written description and analysis of the quality control performed; tables showing closures, a listing and analysis of all unusual circumstances, discrepancies, and deviations; and the Quality Control Plan.
- C. A listing of personnel who worked in the field or were involved with the data processing for this project.
- D. A listing of the brand, model number, serial number and calibration of all instruments and rods used in the project.
- E. A listing of all software, including version, used during the project.
- F. A final station list: use a table format to list each station.
- G. Any Loop Closures, allowable DE for each line segment, and distance and direction of the forward leveling (direction the line was run) shall be shown.
- H. A final Project Diagram: update the diagram submitted with the Survey Plan (see SOW Section 10.2). Submit only a large size, readable plot (approximately 24 x 32 inches). Discuss the final layout with NGS. Note, a digital diagram may be required.
- I. A list of all vertical comparisons (New-Old) to existing bench marks.
- J. A list of the comparison of all repeat level lines.
- K. A completed Project Submission Checklist, see Attachment B.

L. Copies of all written approvals for all modifications shall accompany the final Project Report.

M. Recommendations for future projects.

12. DELIVERABLES

12.1 LABOR, EQUIPMENT, ETC. - The contractor shall provide all labor, equipment, supplies and materials to produce and deliver the products as required under this SOW, except as shown in SOW Section 3. Note, government supplied items are listed in Section 3.

12.2 GOVERNMENT SUPPLIED ITEMS - The contractor shall return to NGS all government supplied records (listed in SOW Section 3) and all unused survey marks, logo caps, stainless steel rods, and accessories.

12.3 QUALITY CONTROL PLAN - Before any fieldwork begins, the Contractor shall submit a Quality Control Plan covering all work (see SOW Section 6). NGS will review this plan as soon as possible and respond with an approval or comment letter (or e-mail) as soon as possible.

12.4 SURVEY PLAN - Before any Phase Two work begins (mark setting, observations, etc.), the Contractor shall submit a Survey Plan (see SOW Section 10.6). NGS will review this plan as soon as possible and respond with an approval or comment letter (or e-mail) as soon as possible. Phase Two fieldwork may commence after the Contractor receives the approval letter (or e-mail).

12.5 PROJECT STATUS REPORTS - After award, the Contractor shall submit project status reports via e-mail to the POCs each week, until the work is complete. Reports are due each Monday by 2:00 P.M. Eastern Time. Negative reports are required. These reports shall include a listing of where work is underway and where work is completed, with dates completed, and any unusual circumstances and/or deviations from this SOW, Project Instructions, and/or Survey Plan. See Attachment G.

12.6 PROJECT DIAGRAM - Submit a diagram showing all level lines on a map background. Submit only a large size, readable plot (approximately 24 x 32 inches). Discuss the final layout with NGS. Show any/all level line junctions to illustrate that ties are being made at all line junctions. All old lines are to be connected as well as HARN and Tide Stations or connections to other agency's marks as directed by the Project Instructions that are along the route. Ties to HARN stations, other agency marks, and Tide Station marks shall be shown. Distances shall also be shown between all monuments on this diagram.

12.7 RAW DATA - Submit all original data marked "ORIGINAL" (manually recorded and automatically digitally recorded) including: GPS visibility diagrams, and digital

photographs. Backup sheets (see digital copy supplied on CD) shall be used and kept by the contractor until the final adjustment is complete and accepted.

12.8 FINAL DATA - Submit paper and digital copies of all files created during data processing and adjustment. The following, as a minimal, shall be included in the submittal package:

A: Hardcopies of the INX, ABS, BOK Files, new-minus-old tabulation, loop closures, and Quad Maps;

B: A CD containing the following data files shall be attached to the folder containing the above files:

- 1) DSC
- 2) BLU
- 3) HGZ
- 4) ABS
- 5) BOK
- 6) Photographs (submit on separate CD)
- 7) Sketch of tidal station(s)

12.9 REPORTS - Submit a Final Project Report, see SOW Section 11. Please also see the sample Final Project Report in Attachment K.

12.10 LEVELING CHECKING PROGRAMS - Field book and field abstract software are required and are dependent on the leveling equipment used for this project. Include a listing of the equipment to be used and processing software to be used in the Survey Plan.

12.11 ORIGINAL LEVELING DATA - Submit all the original, raw data. Include an explanation of the file naming convention (there is a standard naming convention for leveling using the L accession number, See Section 8).

12.12 DESCRIPTIONS AND RECOVERY NOTES - Submit the finalized description file (D-file) from the NGS WINDESC or WDDPROC software. The contractor shall run WCHKDESC (Part of WDDPROC package) to ensure that there are no errors in the files. The descriptions will not be acceptable until this program returns no errors. The contractor shall also manually check the file because the checking program does not find all errors.

12.13 TRANSMITTAL LETTER - Submit a transmittal letter listing all items submitted to, or from, NGS. See Attachment E.

12.14 BENCH MARK PLOTS - Submit USGS paper 7.5-minute topographic maps with all bench marks plotted with circle, dot and leader to designation (SSN).

13. POINTS OF CONTACT

Jeffrey Hale
Contracting Officer Representative
National Geodetic Survey, NOAA
ATTN: N/NGS; SSMC3, Sta. 8753
1315 East-West Highway
Silver Spring, Maryland 20910
Telephone: (301)-713-3171
Fax: (301) 713-4315
e-mail: Jeffrey.Hale@noaa.gov

Ronnie Taylor
Florida State Advisor
National Geodetic Survey, NOAA
c/oFLDEP, Bureau of Survey
and Mapping, MS 105
3900 Commonwealth Blvd.
Tallahassee, FL 32399
Telephone: 850-245-2606
Fax: 850-245-2645
e-mail: Ronnie.Taylor@noaa.gov

Version 2
February 20, 2007

ATTACHMENT J
TIDE COORDINATION REQUIREMENTS

TO
SCOPE OF WORK FOR GROUND SURVEYS

NATIONAL GEODETIC SURVEY
NATIONAL OCEAN SERVICE
NATIONAL OCEANIC AND ATMOSPHERIC ADMINISTRATION
U.S. DEPARTMENT OF COMMERCE

TABLE OF CONTENTS

ATTACHMENT J: <u>TIDE COORDINATION REQUIREMENTS</u>	PAGE
1. GENERAL	3
1.1 TYPES OF TIDES	3
1.2 SPRING AND NEAP TIDES	5
1.3 MEAN HIGH WATER AND MEAN LOWER LOW WATER	5
2. TIDAL PREDICTION	5
2.1 DATA NEEDED TO CALCULATE A PREDICTED TIDE WINDOW	7
2.2 TIDAL TOLERANCE CALCULATION	8
2.3 TIMES OF TIDAL HIGHS AND LOWS	9
3. TIDE 8+	10
3.1 OVERVIEW	10
3.2 TIDE 8+ PROCEDURES	11
4. TIDAL ZONES AND TIDAL ZONING	13
4.1 USING THE TIDAL ZONES IN TIDE WINDOW PREDICTIONS...	16
5. REALTIME MONITORING OF TIDE GAUGES	17
5.1 PHYSICAL MONITORING	17
5.2 MONITORING NOAA REALTIME TIDE GAUGES	17
6. CONTRACTOR INSTALLED TIDE GAUGES.....	17
7. CONTRACTOR DETERMINED TIDAL DATUM	17
8. QUALITY ASSURANCE / QUALITY CONTROL	17

ATTACHMENT J: TIDE COORDINATION REQUIREMENTS

1. GENERAL - The purpose of this section is to provide an overview of tidal terms, tidal variations, tidal characteristics, calculation of photogrammetric tidal windows, and requirements for various types of data sensors.

The word "tides" is a generic term used to define the alternating rise and fall of the oceans with respect to the land, produced by the gravitational attraction of the moon and the sun. Additional non-astronomical factors including configuration of the coastline, local depth of water, ocean-floor topography, and other hydrographic and meteorological influences may play an important role in altering the range of tide, and the time interval between high and low waters, and times of arrival of the tides.

The words "water level" are used to define the height of the surface of a non-tidal body of water, such as a river or lake, above or below datum. The astronomical factors that create a tide have little or no measurable effect on water levels. Water levels are most affected by rain, snow melt, drought, and the release of water from dam created impoundments. Because these factors can not be accurately predicted over a long period of time, accurate long range water level predictions can not be made either.

1.1 TYPES OF TIDES - There are three basic types of tides: semidiurnal (twice-daily), mixed (also twice daily), and diurnal (daily). The first type, semidiurnal, has two high waters (high tides) and two low waters (low tides) each tidal day. A tidal day is the time of rotation of the Earth with respect to the Moon, and its mean value is approximately 24.84 hours. To have a semidiurnal tide, the two high waters for each tidal day must be almost equal in height. The two low waters of each tidal day also must be approximately equal in height. The second type, mixed, is similar to semidiurnal except that the two high waters and the two low waters of each tidal day typically have marked differences in their heights. When there are differences in the heights of the two high waters, they are designated as higher high water and lower high water; when there are differences in the heights of the two lows, they are designated as higher low water and lower low water. The third type, diurnal, has only one high water and one low water for each tidal day.

DISTRIBUTION OF TIDAL PHASE

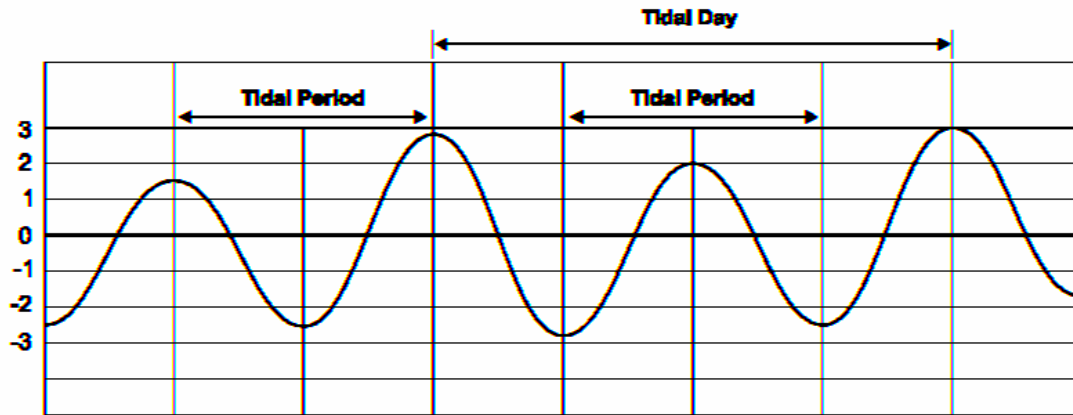

SEMIDIURNAL TIDE

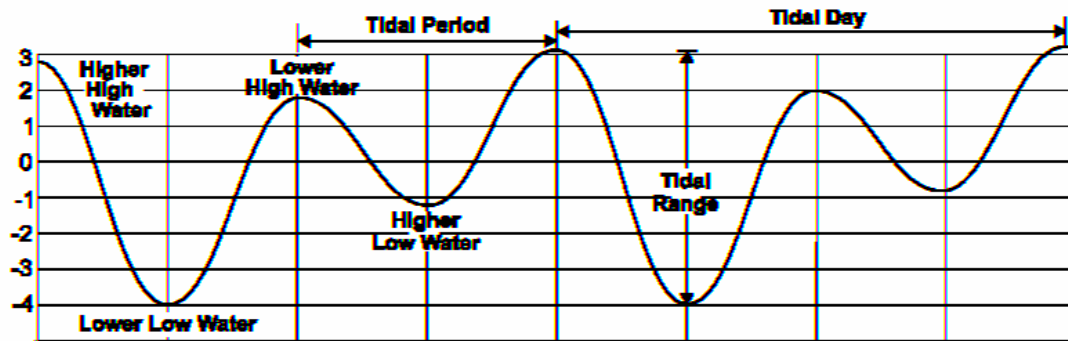

MIXED TIDE

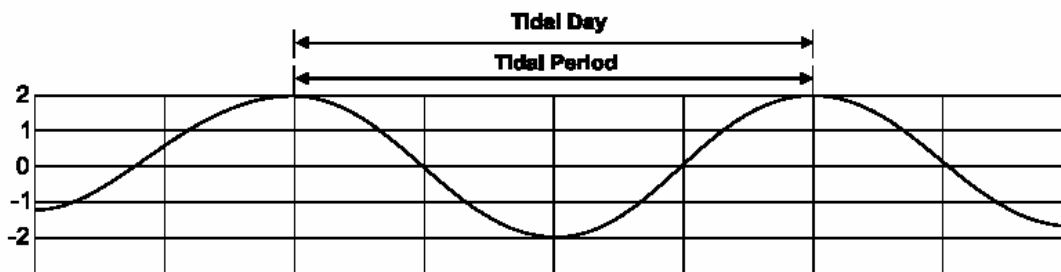

DIURNAL TIDE

1.2 SPRING AND NEAP TIDES - The most important modulations of the tides are those associated with the phases of the Moon relative to the Sun. Spring tides are tides occurring during the new and full moon phases. These are the tides of the greatest amplitude, thus the highest and lowest waters are recorded at these times during each lunar month. Neap tides are tides occurring approximately midway between the time of new and full moon. The neap tide is usually ten to thirty percent less than the mean tidal range. In addition to spring and neap tides, there are lesser, but significant monthly modulations due to the elliptical orbit of the Moon about the Earth (perigee and apogee) and yearly modulations due to the elliptical orbit of the Earth about the Sun (perihelion and aphelion). Modulations in mixed and diurnal tides are especially sensitive to the monthly north and south declinations of the moon relative to the earth's equator (tropic and equatorial tides), and to the yearly north and south declinations of the sun (equinoxes and solstices). The astronomical influence of the moon and the sun upon the earth would seem to imply a uniformity in the tide. However, because of the non-uniformity of the shape and hydrography of the coast, the type of tide can vary over time at a single location and between geographically separated points along the coast. The transition from one type to another is usually gradual either temporally or spatially, resulting in hybrid or transition tides. A further discussion of tide types can be found on the NOAA CO-OPS web site at:

http://co-ops.nos.noaa.gov/publications/Computational_Techniques_for_Tidal_Datums_handbook.pdf

1.3 MEAN HIGH WATER AND MEAN LOWER LOW WATER - The two phases of the tidal cycle that the Shoreline Mapping Program is principally concerned with are Mean High Water (MHW) and Mean Lower Low Water (MLLW). MHW is the arithmetic mean of all high water recordings made during the tide's 18.6 year tidal epoch. Similarly, the MLLW is the arithmetic mean of all lower low water recordings made during the same time period. As these are both arithmetic means of long term recorded values they do not represent the actual high water or low water values for any given tide on any given day.

Coordination of remotely sensed data acquisition with the stage of tide is necessary to be able to confidently delineate the two required tide lines. As the tide rises and falls it scours the shoreline of most of the visible vestiges of the previous tidal cycle, and as we have seen from the above definitions, semidiurnal and mixed tides rise to two different heights during each tidal day, neither of which may be at the mean level during imagery acquisition operations. The use of a debris line on a beach to determine the MHW line is not acceptable because the debris line shows the landward intrusion of the most recent highest high tide or even a storm surge, not the MHW line. The difficulty in delineating the MLLW line from non-tide coordinated imagery lies in not being able to accurately contour through the surf zone. Additionally, tidal coordination of MLLW imagery is necessary to account for any land, such as a sand bar, that projects above the water surface during the low water portion of the tidal cycle. Additionally, MLLW imagery is used to detect any rocks or other obstructions that may be a hazard to navigation.

2. TIDAL PREDICTION - The tides at each end of a long stretch of beach or from the seaward to landward sides of an estuary may have different times of tidal occurrence. Because of this tidal disparity it is clearly impossible to obtain imagery over an extended stretch of beach or shoreline

within an estuary at the exact moment of MHW or MLLW. To overcome this difficulty NGS calculates a height tolerance, within which the tidal level is considered to be at either MHW or MLLW. All tide coordinated imagery must be acquired while the stage of tide is within a calculated range or tolerance of MHW or MLLW. Even with this tolerance it may be necessary to break up a project area into several sub-projects.

Because the tolerance is plus or minus some calculated value, the combination of the plus and minus is referred to as the predicted tide window, or tidal window.

TYPICAL TIDAL CURVE

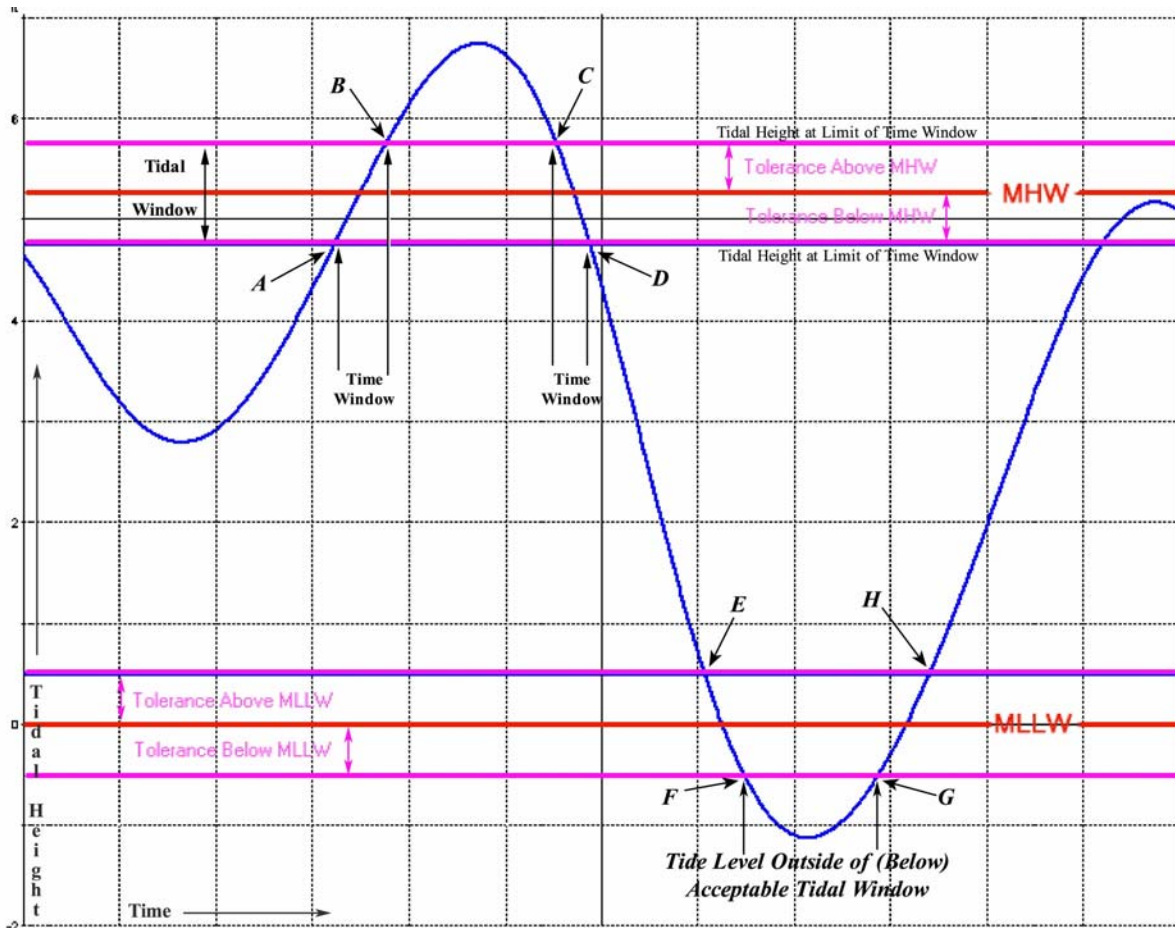

The above diagram shows the relation of the \pm tolerance value in relation to the MHW and MLLW in a tidal cycle. As the level of the tide rises from its previous low point it enters the predicted MHW tide window at point **A**. Imagery can be obtained beginning at this point. The tide continues to rise, eventually reaching point **B**, rising above the tide tolerance, and exiting the tidal window. As the cycle continues and the tide begins to fall again it enters a second MHW tidal window at point **C**. The tide continues to fall until it reaches point **D** and exits the second tidal window. Similarly, the tide continues to fall until it reaches point **E** and enters a MLLW window. It continues to fall until it reaches point **F** and passes out of the predicted window. Upon rising to point **G** the tide again enters the predicted window until it reaches point **H**. Note that not all tide cycles contain two tidal imagery windows. The low water level indicated by the curve on the left side of the diagram does not drop far enough to reach the predicted MLLW window. The curve at the extreme right of the diagram reaches the predicted MHW window, but stays inside it for the entire high water period. Most tide cycles contain no usable tide windows, and most commonly those that do contain windows only have one. The relationship of the \pm tolerance to the MHW is the same as to the MLLW.

2.1 DATA NEEDED TO CALCULATE A PREDICTED TIDE WINDOW - There are three sets of data that are needed to correctly calculate a predicted tide window. 1) The time when the sun will rise above 30° and when it will set to 30° , 2) the heights of predicted highs and lows of tidal movement and the times when they occur, usually for an entire month, and 3) the calculated height tolerance within which imagery can be obtained.

It is of no consequence as to which set of data is determined first, so long as the data is all at hand for input to program Tide8+. For the sake of this example the order will be: Sun angle, calculation of the tolerance, and export/import of tide highs & lows.

To determine the sun angle NGS uses a commercial program that is, unfortunately, no longer available on the open market. The contractor can use any available sun angle calculator. There is an effective one on the U.S. Naval Observatory web site at:

<http://aa.usno.navy.mil/data/docs/AltAz.html>

To calculate the height tolerance and export the monthly highs & lows NGS uses the commercial program Tides & Currents, published by Nobeltec. The contractor is free to purchase any program that they wish, provided it can provide the necessary data and export the data in the required format. (NGS makes no endorsement of any commercial product mentioned in this document.)

To calculate the times that the tide is predicted to be within the acceptable tolerance NGS uses a Government developed program Tide 8+. This program will be provided to the contractor. Training in its use and tide window prediction will be provided to the contractor at a time mutually acceptable to both the contractor and the Government.

For this example tide stations Clearwater, Florida; Savannah River Entrance, Georgia; and San Francisco, California for the month of June 2004 will be used.

The sun angle program predicts the sun will rise to 30° at approximately 0900 hrs during the entire month of June, and will set to 30° at approximately 1745 hrs. (It is important to note here that all times used in this process MUST be based on a 24 hour clock for the program Tide 8+ to properly work. All calculations for tide prediction are done in local time not UTC.)

For greater precision in predicting tidal windows it may be necessary to calculate rising and setting times for the sun for several dates through a month. This is especially true near the solar solstices when the apparent movement of the sun in declination is faster.

2.2 TIDAL TOLERANCE CALCULATION - The numerical values needed to calculate the tidal tolerance for each tide station can be found in the privately published books of tide tables for the east and west coasts. The books necessary are East Coast of North and South America, Including Greenland and West Coast of North and South America, Including the Hawaiian Islands. These books, previously published by NOAA, are available from several vendors. A search of internet web sites can locate these vendors. The Mean Range and Mean Tide Level for each tide station are listed in Table 2.

The numerical values may also be found included within the data for each tide station listed by one of the commercial tide prediction programs.

Example: Clearwater, Florida (Diurnal Tide)

Find the published value for the Mean Range: Clearwater = 1.8 ft

When the Mean Range of the tide station is 5 feet or less, imagery shall be obtained within a tolerance of ± 0.3 ft. of the MHW and MLLW. For the example: MHW imagery could be obtained at Clearwater when the tide stage is between 1.5 ft. and 2.1 ft. The MLLW could be obtained when the tide level is between +0.3 ft and -0.3 ft. MLLW defined as being a tide level of 0.0 ft.

Example: Savannah River Entrance, Georgia (Semi-diurnal Tide)

Find the published value for the Mean Range: Savannah River Ent. = 6.9 ft

When the Mean Range of the tide station is greater than 5 feet, imagery shall be obtained within a tolerance of $\pm 10\%$ of the mean range. For example: MHW imagery could be obtained at Savannah River Ent. when the tide stage is between 6.21 ft and 7.59 ft. Imagery to capture the MLLW could be obtained when the tide level is between -.69 ft and +.69 ft. The tolerance being 10% of 6.9 or $6.9 \times .1 = \pm .69$ ft.

Example: West Coast; San Francisco (Golden Gate) (Mixed Tide)

Due to the diurnal inequality of tides in Alaska and on the West Coast, the Mean Range of tide must be computed. This is done as follows:

Find the published Mean Range and Mean Tide Level for San Francisco (Golden Gate).

Mean range = 4.10 ft. Mean Tide Level = 3.2 ft

The new Mean High Water Level, and thus the new Mean Range = 1/2 the original Mean Range + the Mean Tide Level. $(4.10 / 2) + 3.2$ or $2.05 + 3.2 = 5.25$ ft.

Because the new Mean Range is greater than 5 feet the tolerance is calculated as 10% of 5.25 ft. or ± 0.52 ft. (Rounding up shall only be done if the last digit of the Mean Range is greater than 5.) If the new Mean Range was 5 feet or less the 0.3 ft tolerance would have been used.

2.3 TIMES OF TIDAL HIGHS AND LOWS - A computer file must be created that holds the daily predicted times and heights of the separate high and low water for the tide station being investigated. There are two ways to do this: type a file that includes the times and heights of the highs and lows, or export the highs, lows and times of occurrence from a commercial tide prediction program for importation to Tide 8+. The data for typing can be found for each tide station in Table 1 of the tide books: East Coast of North and South America, Including Greenland and West Coast of North and South America, Including the Hawaiian Islands.

The data **MUST** be typed or exported from the commercial tide prediction program in the following format. Failure to use the format exactly will result in Tide 8+ crashing or returning erroneous data.

Additionally, the typed or exported file **MUST** have a *.TXP file extension.

Example Data Format for importation to Tide 8+:

Tides-SAVANNAH RIVER ENTRANCE	32° 2 N 80° 54 W
From 06 ,01, 2004 to 06 ,30, 2004	
06 ,01, 2004,01:16,6.8,07:33,0.8,13:41,6.0,19:36,1.3	
06 ,02, 2004,02:07,6.5,08:24,0.9,14:33,6.0,20:35,1.5	
06 ,03, 2004,02:57,6.3,09:17,1.0,15:23,6.1,21:37,1.5	
06 ,04, 2004,03:46,6.2,10:08,0.9,16:13,6.3,22:36,1.4	
06 ,05, 2004,04:35,6.1,10:55,0.7,17:02,6.6,23:29,1.2	
06 ,06, 2004,05:25,6.1,11:40,0.5,17:50,6.9	
06 ,07, 2004,00:18,1.0,06:14,6.2,12:24,0.4,18:36,7.2	
06 ,08, 2004,01:04,0.8,07:00,6.3,13:07,0.2,19:19,7.5	
06 ,09, 2004,01:49,0.5,07:44,6.4,13:51,0.1,20:00,7.8	
06 ,10, 2004,02:33,0.4,08:25,6.4,14:35,0.0,20:40,8.0	
06 ,11, 2004,03:17,0.2,09:06,6.4,15:19,0.0,21:21,8.1	
06 ,12, 2004,04:01,0.1,09:48,6.4,16:04,-0.1,22:04,8.0	
06 ,13, 2004,04:44,0.1,10:33,6.4,16:50,0.0,22:51,7.9	
06 ,14, 2004,05:29,0.1,11:25,6.4,17:38,0.1,23:43,7.8	
06 ,15, 2004,06:17,0.1,12:23,6.4,18:31,0.2	
06 ,16, 2004,00:40,7.6,07:08,0.1,13:23,6.6,19:29,0.3	
06 ,17, 2004,01:38,7.4,08:03,0.0,14:23,6.9,20:33,0.4	
06 ,18, 2004,02:36,7.3,09:02,0.0,15:21,7.2,21:41,0.4	
06 ,19, 2004,03:33,7.1,10:02,-0.2,16:19,7.5,22:47,0.2	

06 ,20, 2004,04:31,7.0,11:00,-0.4,17:17,7.8,23:48,0.0
06 ,21, 2004,05:30,6.9,11:55,-0.5,18:14,8.1
06 ,22, 2004,00:45,-0.2,06:27,6.9,12:48,-0.6,19:09,8.3
06 ,23, 2004,01:39,-0.3,07:21,6.9,13:40,-0.6,19:59,8.4
06 ,24, 2004,02:31,-0.4,08:12,6.9,14:30,-0.5,20:47,8.3
06 ,25, 2004,03:20,-0.4,09:01,6.8,15:18,-0.3,21:33,8.1
06 ,26, 2004,04:07,-0.2,09:48,6.6,16:04,-0.1,22:19,7.8
06 ,27, 2004,04:50,-0.1,10:36,6.4,16:48,0.2,23:05,7.4
06 ,28, 2004,05:32,0.2,11:24,6.2,17:30,0.6,23:52,7.1
06 ,29, 2004,06:13,0.4,12:14,6.1,18:13,0.9
06 ,30, 2004,00:39,6.7,06:54,0.6,13:04,6.1,18:58,1.2

File is comma separated ASCII and need not contain one full calendar month of data. However, NGS recommends that a full month of data be exported and processed through Tide 8+ at a time.

First line is: Name of tide gauge being predicted & location of gauge. (The location of the gauge is not necessary to the operation of Tide 8+ and may be omitted. It is shown here because it is part of the data that the commercial program used by NGS exports.)

Second line is the dates of the data

Third and all subsequent lines:

Month, Day, Year, Time, Height, Time, Height, Time, Height, Time, Height

(The spaces shown after the Month and the Day comma are not necessary. Those shown are remnants of the program used to export the data. Tide 8+ will work with or without them.)

All heights are referenced to MLLW. All heights are to .1 of a foot.

All times are based on a 24 hr clock and are in local time, Local Standard Time or Daylight Savings Time. That the times are in 24 hour format is critical. The use of a 12 hr civilian clock will cause erroneous data to be returned by Tide 8+.

3. TIDE 8+ - Tide 8+ is the Government written program that actually calculates the time when imagery tide windows will open and close. These calculations are based on the predicted highs and lows, the sun angle beginning and ending times, and the calculated tolerance.

3.1 OVERVIEW - Because Tide 8+ is an old DOS base program it will not accept input from a mouse or other pointing device. It may also have trouble printing over a network. NGS recommends that the computer on which this program is run has a local printer.

Start the Tide 8+ program.

Over view of Main Menu Functions:

Open TD4 file: Use this option to recall a saved *.TD4 (tide input parameters) file.

- Save TD4 file:** Use this option to save a *.TD4 file
- Path:** Use this option to tell the program the directory where you wish to save TD4 files and the path where the TXP data files exported from the commercial tide prediction program are saved. (For convenience sake, these should be in the same directory.)
- Edit Parameters:** Use this option to manually enter the time and height correctors, the calculated tolerance as well as the starting and ending flight times for the tide station under consideration and other variable data.
- View Tide Data:** Use this option to view the High and Low water tide window predictions before printing them.
- Hard Copy of Tide Data:** Use this option to print the High and Low water tide window predictions
- Change Time Zone:** Do Not use this option. Do Not Change the time zone unless you want the tide window predictions done in Greenwich Time. This option is the number of tide zones away from the photo project that Greenwich time falls. Local time = 0. As all input and output will be in local time no correction is warranted. Changing the time zone after importing data will scramble the data into uselessness.
- Import Other Tide Data:** Use this option to import the TXP file that was manually typed or exported from the commercial tide prediction program.
- eXit:** <Return to DOS>

3.2 TIDE 8+ PROCEDURE - Set the path for a TXP file to be the same path used to save the exported data from the commercial tide prediction program.

Set the path for the TD4 file to be a directory where the input tide station parameters will be saved. (TD4 files are useful for saving all of the input data for a particular tide station for a particular month in case there is any reason to go back and review it. A different TD4 file must be created for each tide station for each month. They also assist in creating a file of the tide window prediction out-put. Tide 8+ has no direct function for saving the high and low water tide window predictions.)

Import Other Tide Data: A menu of all the TXP files that have been saved to the specified directory will appear. Use the Cursor control keys to scroll down to the desired file and press ENTER. No confirmation message will appear.

Edit Parameters: A screen with all of the parameters necessary to predict tide windows will appear.

Check to see that the tide station name and the number of days of data are correct. (Tide 8+ will not crash if less than a month's worth of data are used to calculate tide windows. The output will simply be only for that time period chosen, possibly missing days of adequate tide windows.)

Edit the station name. This is useful if predicting the tide windows in a tide zone rather than on an individual station.

Enter the tide height at MLLW. This equals 0 feet always.

Enter the Range value (The range value is the same as the tolerance. When Tide 8+ was written the programmer did not realize that the word "Range" was used for more than one tidal value. Because all of the people using the program knew what was meant by Range the label was never changed.)

The low tide corrector = 0 (In rare cases there is a constant difference in tide height between a primary and subordinate tide station. When this difference is known the value goes here.)

The low tide ratio = 1 if calculating for a specific tide gauge. For tide zones the ratio will equal some other value that will be supplied to the contractor as part of a tidal zoning diagram. (This value is the ratio of tidal height at a subordinate station to that of its primary station.)

The low tide time corrector = 0 if calculation for a specific tide gauge. For tide zones the corrector will equal some other value that will be supplied to the contractor as part of a tidal zoning diagram. (This value is the time difference in minutes that it takes a subordinate station to reach the same height as its primary station.)

The correctors and ratio are set to equate to no corrections if they have been already accounted for by the commercial tide prediction program before the data was exported. The same holds true for the high tide correctors.

Enter the tide height at MHW. This equals the value of the Mean Range or the new Mean High Water/New Mean Range value that was previously calculated. See 3.2 of this Attachment.

The high tide corrector = either .3 or the calculated Tolerance

The high tide ratio = 1 if calculation for a specific tide gauge. For tide zones the ratio will equal some other value that will be supplied to the contractor as part of a tidal zoning diagram.

The high tide time corrector = 0 if calculation for a specific tide gauge. For tide zones the corrector will equal some other value that will be supplied to the contractor as part of a tidal zoning diagram.

The window begin and end times come from the calculation of when the sun rises to 30° and sets to 30°. They must be in a 24 hour clock format.

Page Down through the remaining data to get back to the Main Menu.
View Tide Data to be sure the output is reasonable.

Print a Hard Copy of the predicted tide windows.

Save the work as a TD4 file.

To save the tide window predictions as a file:

Open the just saved TD4 file

View the data (The data will be saved in a temporary file called *TD4filename.TXT* in the directory where the TD4 file was saved.)

Before viewing the data for the other stage of tide predictions, go to the directory and rename the temporary TXT file. (If it is not renamed, viewing any other data will over-write the data already in the file.)

Repeat the above steps for each month of data for each tide station or tide zone.

Exit the program

Informational Note: If the program used to export tide times and heights can automatically account for the daylight savings time - standard time change that occurs in April and October, the switching of the time within the exported data may cause Tide 8+ to return an Invalid TXP file error message. This problem is easily fixed by opening the original exported data file, looking at the data for the day of the time change and correcting for the change. NGS personnel have found that the most common error is that one day will be listed twice in the first column of data. The data is fixed by simply changing the date of the second one listed.

4. TIDAL ZONING AND TIDE ZONES - Because tide levels and/or the time of a tide can vary considerably within a project area, NGS will supply a Preliminary Tidal Zoning diagram to the Contractor. The diagram delineates various areas within a project area in which all of the tidal parameters are equal. Each zone can be considered to be a subordinate tide station to the main station on which its corrector values are calculated. Tide predictions for each zone used are then calculated as if the zone is a separate tide station. The correctors provided are: High Tide Time Corrector, Low Tide Time Corrector, and Range Corrector. These values are used in Tide 8+ as the input for: High and Low Time Correctors and the Ratio.

The diagram below shows the preliminary tide zones for Narragansett Bay, Rhode Island. Each of the Red polygons is a tide zone. Each zone has a block of data associated to it by an arrow. The block of data contains the Tide Zone Name, the High Tide Time corrector value, the Low Tide Time Corrector, the Range Corrector, and the main tide station used to calculate the correctors. The main tide stations are shown as gold stars on the diagram. Their label is shown in blue. The black lines running north to south are flight lines, which may or may not appear on a diagram.

The High Tide Time Corrector is \pm the number of minutes that the high water event occurs within the zone relative to the time it occurs at the primary tide station. A positive value indicates that the high water event within the zone occurs after that of the primary tide station. A negative value indicates that the high water event occurs before that at the primary station.

The Low Tide Time Corrector is \pm the number of minutes that the low water event occurs within the zone relative to the time it occurs at the primary tide station. The relationship of the \pm time is the same as for high water.

The Range Corrector is the ratio of height of the water within the zone to the height of the water at the primary station.

Because the tide zones are calculated for hydrographic surveys, it is not practical to use every zone when determining the predicted tidal imagery windows. Clearly, an aircraft can obtain data from an entire zone or zones much faster than can a hydrographic survey vessel.

Preliminary Tidal Zoning for Project RI0301 Remote Sensing for Rhode Island Shoreline

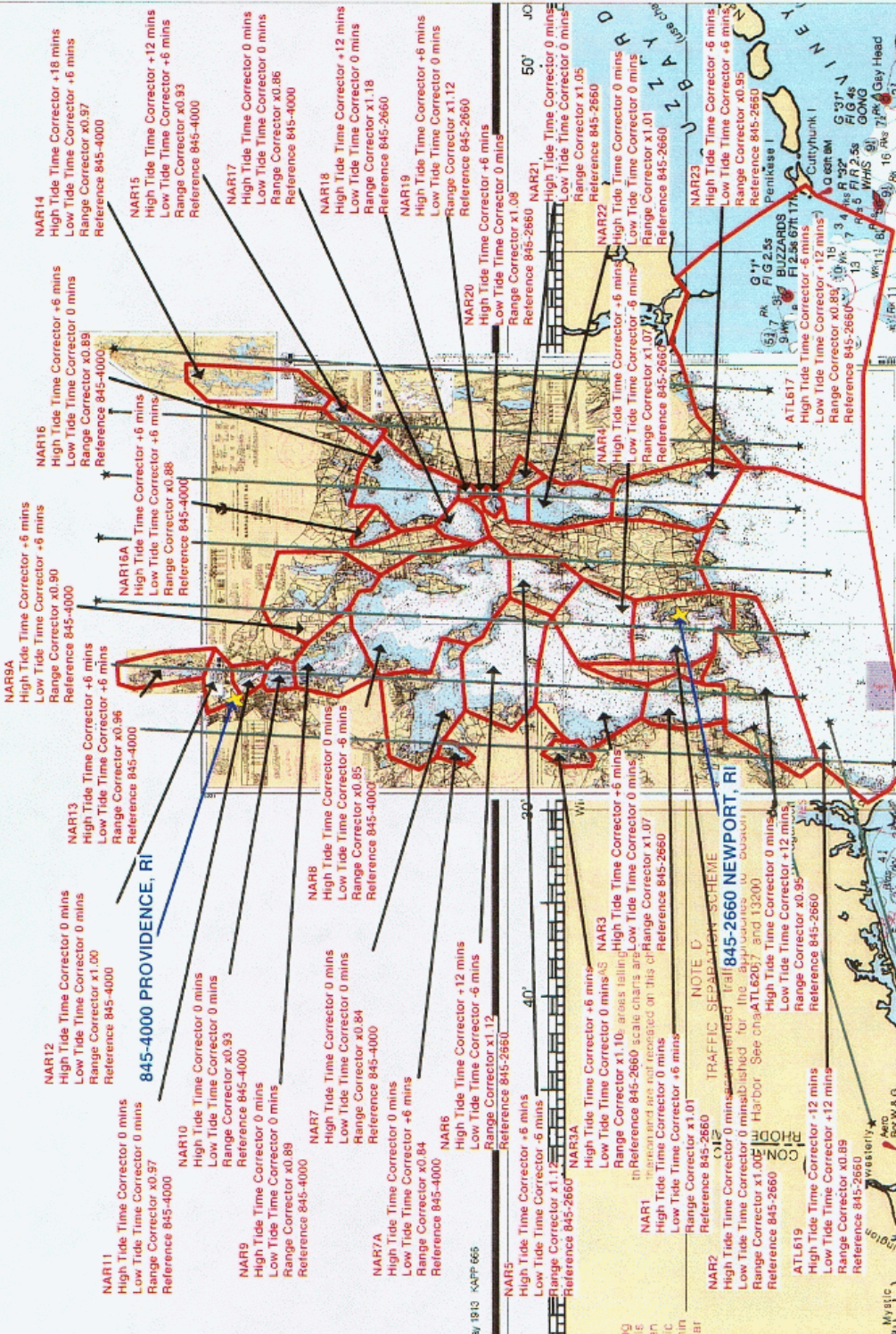

4.1 USING THE TIDAL ZONES IN TIDE WINDOW PREDICTION - First find the two zones that are at the ends of a flight line.

Import into Tide 8+ the monthly tide data for the Primary Station on which the zones are based. Edit the stations parameters in Tide 8+.

Choose one of the zones and rename the station to reflect the tide zone being worked. Apply the zone's corrector values to the appropriate inputs for the Primary Station.

The Low Tide Corrector value from the zoning diagram goes in the Low Tide Time Corrector parameter of Tide 8+.

The High Tide Corrector value from the zoning diagram goes in the High Tide Time Corrector parameter of Tide 8+.

The Range Corrector value from the zoning diagram goes into BOTH the Low Tide Ratio and High Tide Ratio in Tide 8+.

Supply the correct starting and ending times.

Run the program and get hard copies of both the MHW windows and MLLW windows.

Choose the other zone, rename the station to reflect the tide zone being worked and apply the correctors, ratio, and start/end times for that zone.

Run the program and get hard copies of both the MHW windows and MLLW windows.

Compare the output for each zone against the output for the other. If all has gone well each zone should have a series of windows that overlap with the other zone on a daily basis. The window within which that flight line can be flown is from the latest starting time in one zone to the earliest ending time in the other.

If there are no times of overlap, or no windows within which an aircraft could reasonably be expected to fly an entire line, pick a zone approximately half way between the first two.

Perform the calculations for it.

Check the output again for overlap with the other two zones.

It sometimes happens that two distant zones will not overlap with each other, but will with a zone between them. In this case the flight line will have to be broken and flown in pieces so that all of the imagery will be within tolerance.

Repeat this procedure with each flight line to get all the windows.

5. REAL TIME MONITORING OF TIDE GAUGES - In certain areas of the country such as the Gulf Coast or the North Slope of Alaska the tidal range may be so small or so affected by weather that predictions are not useful. In such cases the only way to obtain imagery within the appropriate tolerance may be to observe a tide gauge before and during an imagery flight mission. This is accomplished in one of two ways: 1) Physically monitoring one or more tide gauges in the project area and 2) Monitoring a real-time tide gauge through a radio or cell phone link or from an internet web page. Real time monitoring of tide gauges may be required by NGS. If so, a requirement will be included in the individual project instructions. If NGS does not require real time monitoring the contractor is not precluded from suggesting its usage.

5.1 PHYSICAL MONITORING - Physical monitoring requires a person or persons to be at a tide gauge before the expected level of tide occurs. The person stays in contact with the flight crew via radio or cell phone. The person then keeps the flight crew informed of the actual stage of tide on a continuing basis, telling them when it is proper to begin taking imagery and also when to stop.

5.2 MONITORING NOAA REAL TIME TIDE GAUGES - In certain areas of the country NOAA has Real Time Tide Gauges that can be monitored by the flight crew via radio, cell phone, or internet connection. The flight crew can then tell when it is appropriate to begin or stop taking imagery. These tide gauges are listed on the CO-OPS web site: <http://co-ops.nos.noaa.gov>.

6. CONTRACTOR INSTALLED TIDE GAUGES - The contractor shall, when required by the Project Instructions, install tide gauges. Tide gauge installation shall be in accordance with the CO-OPS publication: Specifications and Deliverables for Installation, Operation, and Removal of Water Level Stations. This publication is available at URL: <http://co-ops.nos.noaa.gov/pub.html>.

Tide gauges shall be installed at locations that will be determined by consultation between NGS and the contractor.

7. CONTRACTOR DETERMINED TIDAL DATUM - The contractor shall, when required by the Project Instructions, determine the local tidal datum for the project area. Datum computation shall be in accordance with CO-OPS publication: Computational Techniques for Tidal Datums Handbook. This publication is available at URL: <http://co-ops.nos.noaa.gov/pub.html>.

8. QUALITY ASSURANCE / QUALITY CONTROL - The contractor shall be responsible for all Quality Control / Quality Assurance of the tidal and geospatial data created and submitted in the course of a project.

NGS will provide the contractor training in how to calculate the predicted tide tolerance at a mutually acceptable time and place. After training, the contractors shall submit predictions to NGS so that NGS can be confident that the Contractor fully understands the procedure for calculating the tolerance. When NGS is satisfied that the Contractor can successfully make the calculations, they will notify the contractor that submission of tide window data is no longer necessary.

Version 1
January 31, 2005

ATTACHMENT K
SAMPLE LEVELING FINAL PROJECT REPORT

NATIONAL GEODETIC SURVEY
NATIONAL OCEAN SERVICE
NATIONAL OCEANIC & ATMOSPHERIC ADMINISTRATION
U.S. DEPARTMENT OF COMMERCE

U.S. DEPARTMENT OF COMMERCE
NATIONAL OCEANIC AND ATMOSPHERIC ADMINISTRATION

NATIONAL OCEAN SERVICE

NATIONAL GEODETIC SURVEY

Charles W. Challstrom

Director

PROJECT REPORT

Second Order Class I
Leveling, Mark Setting and Recovery

TASK NUMBER 8K6D4000

October 10, 2000 - October 23, 2000

George A. Sowell

Project Director - NL4130

Survey Section C

LEVEL PROJECT TITLES ARE SAME AS LINE TITLES

HGZ No. Line Title L25824

BAR HARBOR CORS SITE SURVEY 2000, MAINE

JOB CODE G2

CONTENTS

<i>I.</i>	<i>INTRODUCTION</i>	
	A. Authority	1
	B. Purpose	1
<i>II.</i>	<i>PROJECT AREA</i>	
	A. Locality	1
	B. Limits	1
	C. Terrain	1
<i>III.</i>	<i>CONDITIONS AFFECTING PROGRESS</i>	
	A. Climate and Terrain	2
<i>IV.</i>	<i>DIVIATION FROM INSTRUCTIONS</i>	<i>2</i>
<i>V.</i>	<i>ORGANIZATION</i>	
	A. Personnel	2
	B. Liaison	2
	C. Equipment	2-3
<i>VI.</i>	<i>FIELD WORK</i>	
	A. Chronology	3
	B. Summary for leveling	4
	C. Leveling procedures	4
	D. Data Formats and Handling	4
<i>VII.</i>	<i>STATISTICS</i>	
	A. Number of Days, marks set, recovered....	4
	B. Mark Setting and Recovery	5
	D. Logistics	5
	E. Summary for level procedure.....	5
	F. Attachments	5

PROJECT REPORT
Survey Unit C

I. INTRODUCTION

A. Authority

Leveling Observations at Bar Harbor, MAINE CORS SITE (L25824) ask Number 8K6D4000. Authorized October 11, 2000, and signed for Charles W. Challstrom, Director, National Geodetic Survey.

B. Purpose

The stations established at the site provide a very accurate tie to the antenna as an aid to quickly reposition the antenna should it become necessary. The purpose of this leveling project is to establish precise NAVD 88 heights for the bench marks located near the CORS sites.

II. PROJECT AREA

A. Locality:

BAR HARBOR - The CORS Site is located in the South-southeast part of the state of Maine, from Ellsworth Maine, at the junction of U.S. Highway 1 and State Highway 3, take State Highway 3 south-southeast to State Highway 102. turn left and continue east-southeast on State Highway 3 to the CORS Site, just before reaching Bar Harbor, Maine.

B. Limits

Survey operations were roughly within the boundaries of:

North 44 deg 28 min	North Latitude
South 44 deg 28 min	North Latitude
East 068 deg 15 min	West Longitude
West 068 deg 15 min	West Longitude

C. Terrain

The terrain is flat.

III. *CONDITIONS AFFECTING PROGRESS*

A. **Climate and Terrain**

The climate was mild. The Terrain is flat.

IV. *DEVIATION FROM INSTRUCTIONS*

NONE

V. *ORGANIZATION*

A. **Personnel**

Permanent Employees Title

Sowell, George A. Project Director-S/L
Breidenbach, Donald E. .. Marksetter/GPS,OBS./Rodperson/Utility
Palo, James A. Marksetter/LV Observer/Rodperson/Utility
Palo, Richard A. LWOP
Williams, John M. Computer/LV Observer/Utility

Schedule A Employees

Nowlin, Jason B. .GPS OBS/Rod Person/Recorder/LV OBS, THRU 10/13/00

Contract Employees

Cochran, Cheryl L. .GPS OBS/Rod Person/Recorder/LV OBS
Nowlin, Jason B. .GPS OBS/Rod Person/Recorder/LV OBS

B. **Liaison**

Liaison was maintained with the Field Operations Branch, Spatial Reference System Division.

Contact for **BAR HARBOR**: Gordon Longsworth, College of the Atlantic GIS Laboratory, 105 Eden Street, Bar Harbor, ME 04609 - Phone - 207-288-2271. Fax: 207-288-4126
E-mail: gordon1@ecology.coa.edu

C. **Equipment**

(1) **Level Instruments and serial numbers**
Ni002
456574

V. *ORGANIZATION* (continued)

C. **Equipment** (continued)

(2) **Rod pairs, Unmatched Kern, Invar 1/2 CM GRAD**

Serial Numbers

352134/368781

(3) **Vehicles**

1 - 1 ton Chevrolet/utility bed for mark setting.
1 - 3/4 ton Chevrolet suburban equipped for conventional, Phase II leveling procedures, 2 - Honda CT-110 motorbikes for Phase II leveling.

(4) **Field Equipment**

2 - Data collector, programmable CMT MC-V
2 - Thermometer, Digital Doric MDL-450
1 - Computers, Dell 133 Pentium
1 - Printers - 1 Cannon BJC-240,- various hand tools, mallets, turning plates and pins for leveling and mark setting.

(5) **Office Equipment**

1 - Dell 133 pentium. 1 Cannon BJC-620 Printers, and 1 - XC540 Xerox Copying Machine.

VI. *FIELD WORK*

A. **Chronology**

L25824 BAR HARBOR CORS SITE SURVEY 2000, MAINE

3.555 kms double run
1.990 kms single run
9.100 kms total linear distance
5.545 km forward progress
Setups=201
Leveling date: 10/20/00 - 10/23/00
Bench mark recovery: (7-rec.) Marks set 0:
Mark recovery (10/10/00).

JOB CODE **G2**

VI. *FIELD WORK* (continued)

B. Summary for leveling

Leveling was performed using Second Order Class I standard of accuracy. The CMT MC-V system was used for field data recording and data processing. Data for the project will be released under separate cover.

C. Leveling Procedures

Motorized leveling is with the use of 1-suburban for transporting the instrument man and recorder, and 2-Honda CT110 motorcycles for transporting the rod person, and leveling rods between setups.

Conventional leveling is with all personnel being afoot.

Both leveling procedures were used as dictated by traffic, road shoulders, and other terrain features.

D. Data Formats and Handling

All data was recorded and processed as outlined by Project Instructions, the NOAA NGS Operations Manual, and the Geodetic Leveling Manual.

VII. *STATISTICS*

A. Number of Days, Leveling, Marks set, and recovery

1. Personnel Days

0	----	Project Director S/L
3	----	Computer
3	----	Mark setting/recovery
0	----	Maintenance
4	----	Activity not defined
2	----	Level Observer
2	----	Recorder
4	----	Rod Persons
0	----	Travel
0	----	Holiday
0	----	Annual Leave
3	----	Sick Leave
<u>3</u>	----	LWOP
24	----	Total

VII. STATISTICS (continued)

B. Marks Set and Recovery

Mark setting and recovery were performed according to project instructions, established procedures, and mark setting manuals and memorandum.

The computer printout of the "**Vertical Bench Mark and Field Statistics**" for each level line are attached.

New marks established

0 ---- Class A
0 ---- Class B
0 ---- Total

Marks recovered

3 ---- Class A
3 ---- Class B
1 ---- Class C
0 ---- Class D
7 ---- total

C. Logistics

The field computations and project support was managed from the National Geodetic Survey Field Office in Bangor, Maine.

D. Summary for levels procedure

Both leveling procedures were used as dictated by traffic, road shoulders, and other terrain features. (see Item C Page 4)

E. Attachments

Project Instructions (1-set)
Letter Transmitting Data (1-sheet)
Memo from BM Setters (1 sheets)
List of Contacts (1-sheet)
Bench Mark Statistics (1 Sheets)
Field Statistics (1 sheets)
Abstract for CORS Site Levels (6 sheets - stapled)
NEW - OLD sheet for tie marks (1 sheet)

Version 2
February 20, 2007

**ATTACHMENT L
HEIGHT MODERNIZATION SURVEYS**

TO
SCOPE OF WORK FOR GROUND SURVEYS

NATIONAL GEODETIC SURVEY
NATIONAL OCEAN SERVICE
NATIONAL OCEANIC & ATMOSPHERIC ADMINISTRATION
U.S. DEPARTMENT OF COMMERCE

ATTACHMENT L – HEIGHT MODERNIZATION SURVEYS

1. GENERAL – These specifications are in addition to those in the “Main Text” portion of this Scope of Work (SOW) and are specific to Height Modernization (HtMod) surveys.

2. DATA FORMAT – All HtMod projects are required to be in Blue Book format and all require ties to CORS. Note, a new version of the NGS On-Line Positioning User Service (OPUS) called OPUS-DB may meet the Blue Book requirement, when ready.

3. SURVEY WORK - GPS ground surveying methods shall be used for HTMOD work specified in SOW, References A and B, and the Project Instructions.

3.1. HORIZONTAL CONTROL - A sufficient number-of high accuracy stations (as required by NGS-58 and/or SOW, Reference B) shall be recovered to provide horizontal control for the project. If the distribution is inadequate, the contractor shall then recover A-order, B-order, first-order, or second-order horizontal control stations (in that order) **established with GPS**, limiting the search to the number and/or area needed to provide enough control for the project. If there is still insufficient horizontal control for the project, the contractor shall extend the area of the search until enough control is found. Notify NGS of this situation immediately.

If the existing high accuracy GPS horizontal control stations are of sufficient accuracy and distribution, the primary network of 5-hour sessions may not be required. Contact NGS.

3.2. VERTICAL CONTROL - A sufficient number of high accuracy vertical stations (bench marks) shall be recovered to provide vertical control for the project. If there is insufficient vertical control for the project, the contractor shall extend the area of the search until enough control is found. Notify NGS of this situation immediately.

3.3 MARK MAINTENANCE - For all marks used in this survey, perform mark maintenance, if required, including replacing logo cap lids if missing. See SOW, Section 10.5K for additional information. Notify NGS of any other marks that need mark maintenance.

3.4 STATION TABLE – A Station Table is required, see SOW, Section 10.6.

3.5 NGS GUIDELINES - The Contractor shall follow guidelines for establishing GPS-derived heights documented in “NOAA Technical Memorandum NOS NGS-58” (ellipsoidal) (SOW, Reference A) and “A Guide for Establishing GPS-Derived Orthometric Heights (Standards: 2 cm and 5 cm)” (orthometric)(SOW, Reference B). **Note, use 45 minute observation periods rather than the 30 minutes specified in NGS-58 for stations other than “control stations and primary base stations.”**

3.6 TRIPODS - Fixed height tripods shall be used for HtMod surveys.

4. DATA PROCESSING – Data processing will vary with the survey equipment and methods used. Usage of CORS is required.

4.1. CONTROL AND BASE STATIONS - Vector processing shall be performed using the latest version of NGS software package PAGE-NT or equivalent. The equivalent of PAGE-NT is subjective, and is based on the software's ability to correct for the same systematic errors that PAGE-NT corrects, apply the NGS required antenna phase pattern variations, and reproduce the same results as PAGE-NT. This determination will be made by NGS.

The NGS PAGE-NT software package and User's Manual are available via anonymous FTP from NGS (see Attachment C). Follow the vector processing guidance below and the PAGE-NT User's Manual.

Vectors shall be processed using a 15-degree elevation mask

The grouping of vectors into processing sessions for each day of observations is determined by two factors: 1) the required reference station and 2) the distance of each solved station from the reference station. This vector distance determines the final solution type to be run in PAGE-NT. Reference station requirements are detailed in the sections below. Use the following table for grouping vectors into sessions according to vector length:

PAGE-NT Final Solution Type Determination

Vector Distance for Processing Session	Final Solution Type
Less than 5km	L1 Fixed
5-100km	Ion-Free Fixed

IGS precise orbit data and NGS National CORS data must be used in data processing. For information on downloading CORS data and ephemeris data from NGS via the Internet, see Attachment C.

International Earth Rotation Service Terrestrial Reference Frame (ITRF) station coordinates shall be used for all vector reductions. Information about ITRF is available on the NGS Web site, under "PRODUCTS and SERVICES." See: http://www.ngs.noaa.gov/products_services.shtml . The current ITRF epoch must be used in computations. If ITRF coordinates are not available for the reference stations, transform coordinates from NAD 83 with NGS program HTDP (Horizontal Time Dependent Positioning; see: <http://www.ngs.noaa.gov/TOOLS/Htdp/Htdp.html>).

The Antenna Height value entered into the PAGE-NT “Station Information” menu “Up” field is the distance from the monument to the Antenna Reference Point (ARP). For example, 2.000 meters is the Height-of-Instrument for some fixed height tripods. The monument for a CORS is generally coincident with the ARP; therefore, 0.000 is entered for a CORS station unless an offset is listed on the CORS coordinate sheet. PAGE-NT will automatically add a constant factor for the ARP to L1 phase center distance when it merges the data.

Review the PAGE-NT generated plots and text outputs to analyze each processing session. PAGE-NT’s overall RMS-of-fit of the post-fit, double-difference residuals should not exceed 2.0 cm. Investigate individual satellites with a relatively high RMS or where integers can not be fixed. Also review the files for input errors such as improper reference station coordinates, antenna height errors, or improper station names. Check all manual input and indicate that it has been checked by placing “check marks” next to each entry; the checker shall also initial each page.

4.2 SECONDARY AND LOCAL STATIONS - For these stations, vector processing can be performed using the GPS manufacturer’s latest version of the vector processing software package, with NGS approval.

Vectors shall be processed using a 15-degree elevation mask.
Refer also to publication NGS-58.

5. DATA ADJUSTMENT

For computation of the positions and ellipsoid heights, the control and primary networks will be combined into one top level network, and the secondary and local networks shall be combined into one lower level network. The control used will include all CORS, FBN/CBN stations, and any stations adjusted in previous levels of the project. Four adjustments are required for each of these two levels of the network, each consisting of: (1) free (minimally constrained) with one control station fixed, (2) constrained with all CORS stations fixed, (3) constrained with all control stations fixed (horizontal and ellipsoidal heights), and (4) final free with accuracies.

For computation of the orthometric heights, the top level and lower level networks shall be combined and adjusted as one network. Two adjustments are required for this network: (1) free with one control station (with NAVD 88 orthometric height) fixed, and (2) fully constrained with all vertical control fixed.

For further explanation see NGS-58 and SOW, Reference B. Regarding the fully constrained vertical adjustment, the contractor shall begin by performing an adjustment with all bench marks fixed and analyzing the results to determine which bench marks agree and which don't. After non-fitting bench marks are eliminated, a new adjustment will be performed and the results sent to NGS, with explanations, for approval.

CHECKING PROGRAMS - Execute the following four programs and submit the output:

COMPGB - tests the consistency and compatibility of the two required files, i.e., the B-file (GPS Project and Station Occupation Data) and the G-file (GPS Vector Data Transfer file) for a GPS project.

OBSDES - compares a horizontal Blue Book Description data set with its respective Blue Book Observation data set. OBSDES produces a list of error messages along with the description data set record and observation data set information.

OBSCHK - checks the Blue Book B-file and the G-file.

CHKDESC - validates all descriptions in a description (*.DSC) file.

6. DELIVERABLES

6.1 HTMOD ADJUSTMENT AND CHECKING PROGRAMS - Submit a paper copy of the output for programs COMPGB, NEWCHKOB, OBSCHK, OBSDES, CHKDESC, BBACCUR, and ELLACC. Submit paper copies of all ADJUST files. Also, submit the digital data sheet or coordinate file for stations used for fixed control during the adjustment (CORS log/coordinate sheets, NGS data sheet for HARN and bench mark coordinates, etc.).

6.2 ORIGINAL HTMOD DATA - Submit all the original, raw data, RINEX data, precise ephemeris, and vector files. Include the CORS RINEX data files used for processing. For all RAW and RINEX data files not named by their occupied station four character ID, submit an index of station names to RAW and RINEX file; see Section 10.9.

7. HTMOD STATION SELECTION SPECIFICATIONS

Generally, station selection shall be based on the following criteria. Specific requirements are project dependent and the following criteria will be supplemented by those project-specific requirements.

Unless specified otherwise, the overall HtMod project shall consist of stations spaced on average approximately 5 km apart. The actual station spacing shall be flexible enough to allow for optimum station selection but may not exceed the spacing limits specified in NOS-NGS-58.

Horizontal control stations shall be distributed in accordance with NOS-NGS-58. Vertical control stations shall be distributed in accordance with the "Guidelines for Establishing GPS-Derived Orthometric Heights." Existing survey monuments that don't qualify as horizontal or vertical control may be used for local network stations instead of

setting new marks. In fact, it is preferred that existing marks be used, as it saves the time and expense of setting new monuments, as long as the existing monument meet the criteria listed below.

For the list of considerations for every monument (new or old, control station or local network station) in the project, see Attachment D, STATION SELECTION GUIDELINES. The intent is to ensure that stations will be stable and usable years after the survey is completed. Each of the considerations is important, and so, they are not prioritized.

Version 2
February 20, 2007

ATTACHMENT M
SAMPLE STATION TABLE, (BLANK AND FILLED-IN)

TO
SCOPE OF WORK FOR GROUND SURVEYS

NATIONAL GEODETIC SURVEY
NATIONAL OCEAN SERVICE
NATIONAL OCEANIC & ATMOSPHERIC ADMINISTRATION
U.S. DEPARTMENT OF COMMERCE

Version 1
February 20, 2007

ATTACHMENT N
SURVEY DISK DIAGRAMS

NATIONAL GEODETIC SURVEY
NATIONAL OCEAN SERVICE
NATIONAL OCEANIC & ATMOSPHERIC ADMINISTRATION
U.S. DEPARTMENT OF COMMERCE

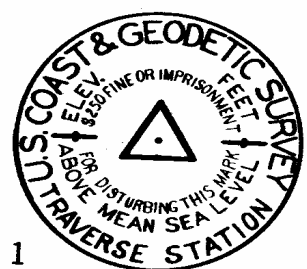

1

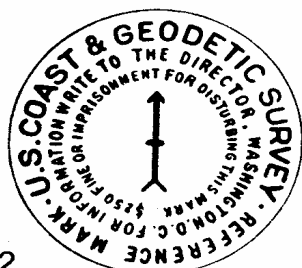

2

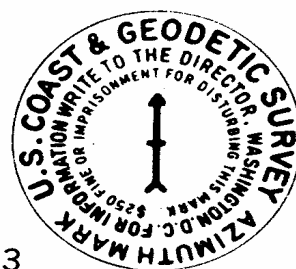

3

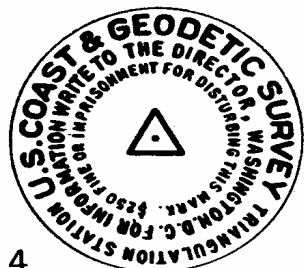

4

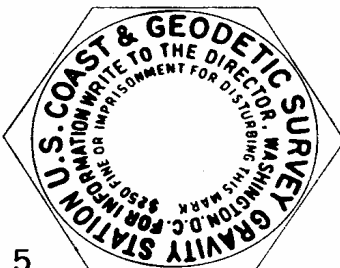

5

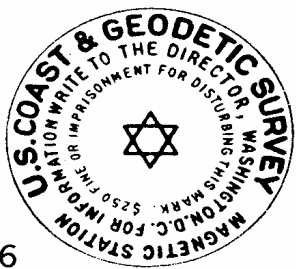

6

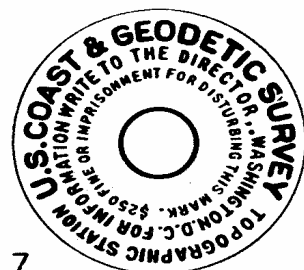

7

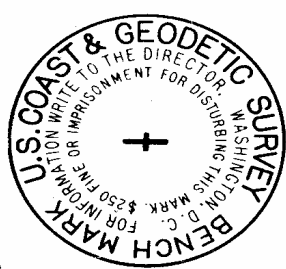

8

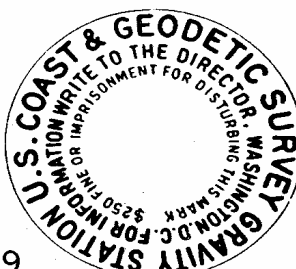

9

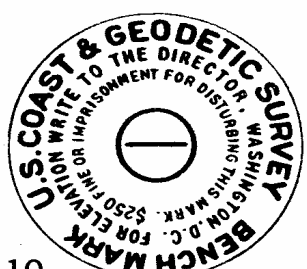

10

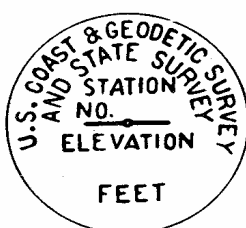

11

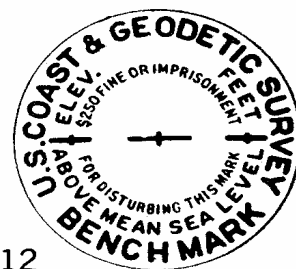

12

- | | | |
|-------------------------------------|-------------------------------------|-------------------------------------|
| 1. Traverse station mark. | 6. Magnetic station mark. | 11. State Survey mark. |
| 2. Reference mark. | 7. Topographic station mark. | 12. Geodetic bench mark (old type). |
| 3. Azimuth mark. | 8. Geodetic bench mark (new type). | |
| 4. Triangulation station mark. | 9. Gravity station mark (new type). | |
| 5. Gravity station mark (old type). | 10. Tidal bench mark. | |

Standard marks of the U.S. Coast and Geodetic Survey

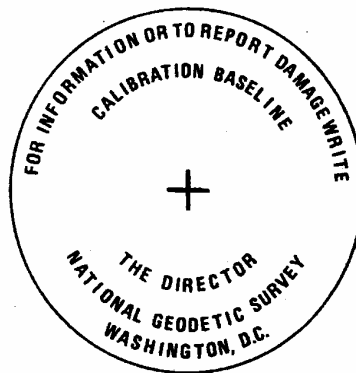
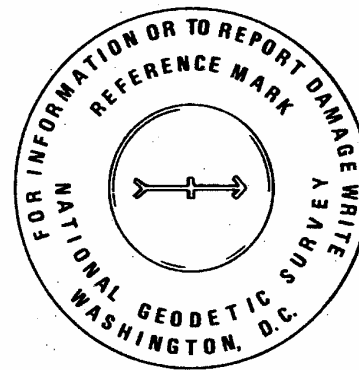
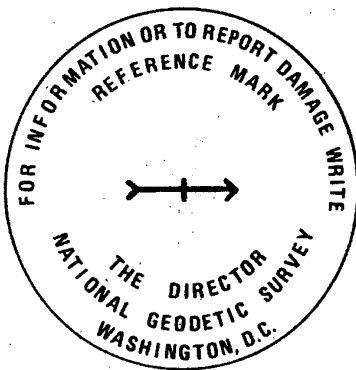
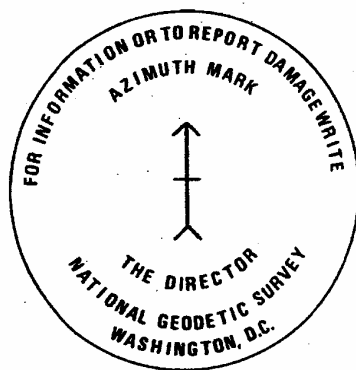
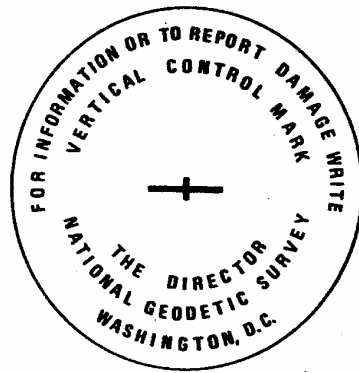
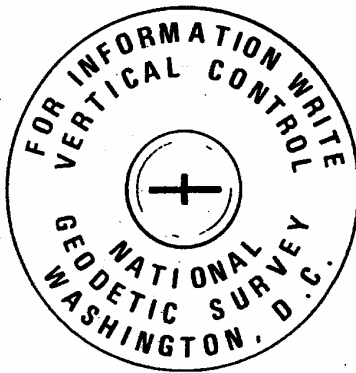

Standard marks of the National Ocean Survey/National Geodetic Survey

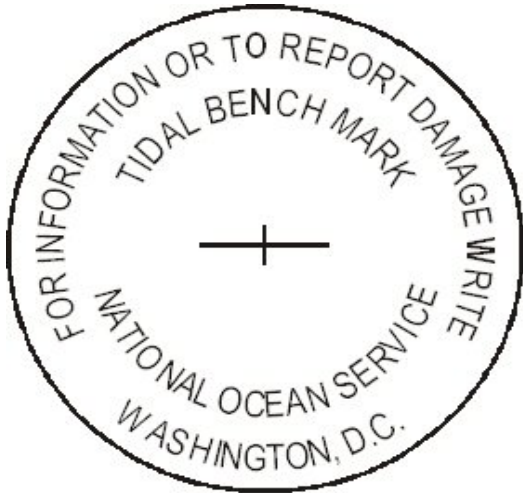

**National Ocean Service
Tidal Bench Mark**



**National Ocean Service
General Usage Disk**



**National Geodetic Survey
New Geodetic Control Disk**

Version 3A
February 20, 2007

ATTACHMENT O
GROUND PHOTO CONTROL

NATIONAL GEODETIC SURVEY
NATIONAL OCEAN SERVICE
NATIONAL OCEANIC AND ATMOSPHERIC ADMINISTRATION
U.S. DEPARTMENT OF COMMERCE

TABLE OF CONTENTS

ATTACHMENT O: <u>GROUND PHOTO CONTROL</u>	PAGE
1. INTRODUCTION.....	3
1.1 CHECK POINTS.....	3
1.2 GROUND CONTROL.....	3
1.3 AIRBORNE KINEMATIC GPS (KGPS) USED.....	3
1.4 GROUND CONTROL ONLY USED.....	3
1.5 NGS FORMS.....	3
2. CONTROL RECOVERY.....	4
2.1 CORS TIES.....	4
2.2 SURVEY MARK TIES.....	4
2.3 MARK DESCRIPTIONS & RECOVERY NOTES.....	4
2.4 CARE OF RECOVERY.....	4
2.5 NGS DATASHEETS.....	5
2.6 SURVEY DISKS.....	5
2.7 INTERSECTION STATIONS.....	5
3. SURVEY METHODS	5
3.1 CONVENTIONAL SURVEY POSITIONING TECHNIQUES.....	5
3.2 GPS SURVEY POSITIONING TECHNIQUES.....	5
3.3 CONNECTIONS TO NSRS.....	6
4. PENCIL RUBBINGS.....	6
5. PRE-MARKED PHOTO CONTROL POINTS.....	6
6. PHOTO IDENTIFICATION.....	6
7. CONTROL STATION FORM.....	7
8. PHOTOGRAPHS AND MAPS.....	7
9. DATA PROCESSING.....	8
10. QUALITY CONTROL.....	8
11. GROUND CONTROL REPORT	8
ANNEX A (Photo Panel Specifications).....	10

ATTACHMENT O: GROUND PHOTO CONTROL

1. INTRODUCTION - Ground photo control is used to establish scale, azimuth, and a coordinate system. For photography, pre-marked photo panels or photo identified control points may be used. Blue-booking (entering data into NGS' data entry format) is not required for check points, ground photo control points, or for temporary survey points. If permanent survey marks are set, then Blue-Booking including digital descriptions in NGS format are required, see 2.3, below.

1.1. CHECK POINTS - For shoreline mapping projects using film or digital cameras, at least four check points are required. These points shall have horizontal and vertical positions. In Alaska and other areas outside the continental United States where NAVD 88 bench marks are not available, the Contractor shall make GPS ties to tidal bench marks within the project area. The check points shall be approximately evenly spaced in the project area and shall be positioned using specifications listed below. On large projects, use at least one check point for every four strips, and at least one near each corner of a block. **These four check points shall not be used in the aerotriangulation computations, but rather serve as an independent check of the photogrammetric solution.** The contractor shall compare the ground positions of the check points to the results derived from the aerotriangulation solution and shall report these results to NGS in table form in the Ground Control Report. Note, it is recommended that at each of the four locations, multiple points be located.

1.2. GROUND CONTROL - The contractor may propose additional ground control to be used in the aerotriangulation. The Contractor shall determine an adequate number and distribution of ground control points. A description of the plan and the number, type and spacing of these points shall be included in the Technical Proposal. See also SOW, Section 6.2, Section 2.3 below, and MANUAL OF PHOTOGRAMMETRY (MOP), Fifth Edition, 2004.

1.3. AIRBORNE KINEMATIC GPS (KGPS) USED - For shoreline mapping projects relying mainly on airborne KGPS, the Contractor shall use at least four check points and may use additional control as described above in Section 1.2. See MOP, Fifth Edition, pages 1112-1113.

1.4. GROUND CONTROL ONLY USED - For Coastal Mapping Program (CMP) projects using ground control exclusively, the amount and distribution of the required photo control will depend on the project size, shape, and number of models, (for general guidelines, see MOP, Fifth Edition, pages 1111-1112. CMP projects (with no airborne KGPS) shall have at least the following photo control: a point at the beginning and end of each strip, a point every five photos along a single strip, points near the corners of a block, a point every seven photos around the perimeter of a block, and additional vertical points in the interior of the block. In addition, at least four check points are required as described in Section 1.1 above.

1.5 NGS FORMS – The required forms and photographs are listed in Attachment Q, Introduction.

2. CONTROL RECOVERY - All surveys shall be tied to the National Spatial Reference System (NSRS) using at least two points (CORS and/or survey marks). The specified datums are NAD 83 and NAVD 88.

2.1. CONTINUOUSLY OPERATING REFERENCE STATION (CORS) TIES - NGS recommends that all surveys be tied to the NSRS by using the CORS system. If a CORS is used, no recovery is required for that CORS. See the CORS map on the NGS www site at: <http://www.ngs.noaa.gov/CORS/> .

2.2. SURVEY MARK TIES - If the NSRS tie is done through survey marks, the marks shall be at least second-order horizontal and third-order vertical, and on-line or NGS format digital recovery notes are required. NSRS survey marks may be found in the NGS database at: <http://www.ngs.noaa.gov/cgi-bin/datasheet.prl> .

2.3. MARK DESCRIPTIONS AND MARK RECOVERY -

A. **Mark Descriptions** - If a new, permanent survey mark is set, a digital description in NGS format using NGS software WDDPROC or WINDESC is required, see Attachment S. If a temporary survey mark (iron pin, PK nail, etc.) is set, complete NOAA Form 76-82, "Control Station Identification". Digital photographs are required in both cases, two for temporary points and three photos for permanent marks. See Section 8 below, and Attachment R.

B. **Mark Recovery** - For NSRS survey marks recovered, the NGS on-line recovery method may be used (see: http://www.ngs.noaa.gov/FORMS_PROCESSING-cgi-bin/recvy_entry_www.prl), unless Ground Surveys under Attachment P are also being conducted in which case NGS software WDDPROC or WINDESC shall be used. For the on-line recovery system, complete all required fields and enter recovery information in the text box at the bottom of the form. Include in the Ground Surveys Report a list of all marks recovered using this on-line system, and a printout of each recovery note with photos. Recoveries may also be made using NGS software WDDPROC or WINDESC. Digital photographs are required in both cases, see Attachment R.

2.4. CARE OF RECOVERY - Recovery of survey marks shall be done with the utmost care to provide accurate information. The description of an existing station shall be carefully evaluated and checked with ground details, and the distances and directions to reference marks should be checked. This will help ensure that the mark found is in fact the station being searched for and not a replacement station, a reference mark, an azimuth mark, or a nearby mark set by another agency with the same or similar name. The stamping and the agency name must agree exactly with the datasheet from the NGS database. See Attachment N for drawings of different types of survey disks used by this agency. Note that azimuth marks and the main triangulation station have the same name and date stamping, just different words factory stamped or cast into the disk ("AZIMUTH MARK" or "TRIANGULATION STATION").

2.5. NGS DATASHEETS - Datasheets can be downloaded from the NGS WWW site at: <http://www.ngs.noaa.gov/cgi-bin/datasheet.prl> by clicking on “DATASHEETS”, then on “Radial Search”. Enter the approximate latitude and longitude, scroll down to “Horizontal Order-2 or better”, and then click on “Submit Query”. GPS connections may also be made to PACS (scroll down the list), which are located at many airports. The NGS database may also be searched by station name, Permanent IDentifier (PID), etc. Datasheets should be downloaded at the beginning of each project to ensure that the most recent data is available. See sample in Attachment Q. Data sheets for CORS may be found at: <http://www.ngs.noaa.gov/CORS/> and then click on “DOWNLOADS”, then on “Standard Files”, and then on “Data Sheet”.

2.6. SURVEY DISKS - NGS and its parent organization NOS and its predecessor organization USC&GS have used many different letter castings on disks. To help eliminate erroneous mark recoveries, review the drawings of these many disk styles in Attachment N. Note, the letters cast or stamped into a disk generally include the agency name and the type of disk (reference mark, azimuth mark, etc.), and are produced during the manufacture of the disk. These letters are different from the designation (name) and year stamped by the surveyor when the mark is set. Disk stampings shall not be altered at any time.

2.7. INTERSECTION STATIONS - Intersection stations such as stacks, tanks, navigational aids, and radio masts may be used to establish an azimuth, but must have an azimuth check since they are subject to erroneous recovery. Such structures may be demolished and rebuilt close to but not in exactly the same location, or structures of similar appearance may exist in the same vicinity. The recovery of such stations should be verified not only by visiting the station site but also by questioning local officials. Note, on-line recovery notes are not allowed for Intersection Stations, but WDDPROC or WINDESC recoveries are allowed.

3. SURVEY METHODS - Either conventional or GPS surveying techniques may be used.

3.1. CONVENTIONAL SURVEY POSITIONING TECHNIQUES - If conventional techniques are used, survey methods utilizing leveling, traverse, triangulation, and/or trilateration may be used to position photo panels or to perform photo identification. Surveys should result in horizontal accuracies of 0.1 meters, and vertical accuracies of 0.2 meters, or better. All surveys shall have an observational check including closing position and closing azimuth checks for horizontal surveys and an elevation check for vertical surveys.

3.2. GPS SURVEY POSITIONING TECHNIQUES - GPS techniques, such as static GPS or kinematic GPS (stop & go, etc.), which result in horizontal accuracies of 0.1 meter (vertical 0.2 meter) or better may be used to position photo panels and/or for photo identification. Each new point should be occupied twice, independently, and for the length of time necessary to meet the accuracy requirements. Positioning should be done by ties to CORS. Note: the CORS map on the NGS web page shows “National CORS” and “Cooperative CORS.” The data for the former are in the NGS database, the latter data are not. Cooperative CORS operators hold their own data and are only required to hold data for 30 days. Download data as soon as possible,

especially if the collection rate was one second. **Weather data is not required**, and weather (meteorological) data is not available at CORS.

3.3. CONNECTIONS TO NSRS - Both horizontal and vertical surveys shall be connected to the National Spatial Reference System (NSRS). Connections should be made to at least two NSRS stations (this may be two CORS). Panels may be constructed directly over third-order or better, NSRS stations.

4. PENCIL RUBBINGS - The contractor shall capture a pencil rubbing of a marks' stamping (disk or logo cap) each time the mark is occupied for observations. Use the form found at: <http://www.ngs.noaa.gov/PROJECTS/FBN/> (Click on "Forms," and then click on "Pencil Rubbing Form"), and in Attachment Q. When not feasible to make the required rubbing, a sketch of the mark shall be substituted accurately recording all markings. Photographs are not required at each occupation.

5. PRE-MARKED PHOTO CONTROL POINTS - The Contractor shall mark photo control panels (or targets) with a temporary point such as an iron pin or PK type nail. Photo control points should have the following characteristics: be in the required location on the photograph, allow positive identification of the image point, and provide good measurement characteristics of the image point. Of these, location is the over-riding factor. Panels may be installed directly over third-order or better, NGS NSRS stations, and also over newly positioned temporary marks accurate to 0.1 meter, or better, relative to the NSRS.

A triangular or square panel should be centered directly over the photo control point, with locating "wings" placed perpendicular to each side of the center panel. See Annex A, "Specifications for Premarking Control Stations" for recommended panel shapes and sizes. Modifications to the wings may be made as required by local circumstances. Wings may be placed further from the panel than the preferred distances listed on the diagram, but may not be located closer. A wing or wings may be deleted if the panel can be positively identified and the location of the panel precludes the placement of all wings. The identification and positioning of a nearby photo identifiable point is recommended in all cases and such a point shall be established when fewer than two wings can be placed at the panel. See also the Manual Of Photogrammetry, Fifth Edition, 2004, Sections 15.1.2.6, 15.1.3.2, and page 1114 for a target designed for softcopy photogrammetry.

6. PHOTO IDENTIFICATION POINTS - Photograph identified (photo ID) points should be temporarily marked, if possible. If photo ID points are used, the Contractor shall search for features that can be seen and identified in the aerial photographs. The points identified shall be on a feature minimally elevated from the ground, if possible, such as a lone boulder along a shoreline. A point with high contrast such as the intersection of two sidewalks, an intersection of two highway paint stripes, or similar is ideal. Extreme care must be exercised to ensure that the

point can be positively identified on a photo-pair and that the point has not changed since the date of the photography.

7. CONTROL STATION FORM - Control Station Identification (CSI) (NOAA Form 76-53) shall be completed for each check point, photo panel and photo ID point. See Attachment Q for sample forms (blank and filled-in), and sample ground photos. All modifications to the standard panel must be depicted on the CSI form. In cases where the target panels have a high probability of vandalism, it is recommended that two nearby photo identifiable objects be positioned for redundancy.

8. PHOTOGRAPHS AND MAPS - While at the site, three digital photographs shall be taken of each permanent mark, and two photographs shall be taken of each check point, panel, and/or photo identifiable point used. Photographs are only required during one visit to a mark.

TABLE OF DIGITAL PHOTOGRAPH REQUIREMENTS

	Permanent Marks	Check Points, Photo Control Points
Close-Up	V, Stamping legible	not required
Eye-Level	V, Mark & vicinity	H, vicinity
Eye-Level	H, show obstruction(s)	H, vicinity

V = vertical camera line-of-sight

H = horizontal camera line-of-sight

For horizontal photos show the mark in the foreground (with tripod in place, if possible) and the nearest obstruction or feature, such as trees, roads, bridges, telephone poles and buildings in the background. See Attachment R for detailed specifications. For photographs of photo control points, the two horizontal views shall show the photo point from two different angles, with the tripod in place, if possible. Check points, photo control points, and temporary survey points all require the same formats for photo captions and photo file names. These are explained in Attachment R Sections 3 and 4. Note, file names for photographs of all three of these type points shall begin with “RE”. For these three type points, leave the “PID” field blank and the “Station Type” field blank.

Place a sign in each photo (except the close-up) showing the name of the mark, panel, or point (may use a white board and heavy marker).

In addition, the location of each panel, photo identifiable point, and survey mark used shall be marked on a large scale map or chart of the area. See Attachment Q for samples of both.

9. DATA PROCESSING - Survey ties using CORS data should be processed using the On-line Positioning User Service (OPUS), see: <http://www.ngs.noaa.gov/OPUS/>. The OPUS www site states that at least two hours of data is required. Make sure the Rapid Orbits are available (usually one work day) before uploading data to OPUS. When OPUS is run, the default is that OPUS uses only National CORS. Cooperative CORS may be closer to the project area and may be selected manually within OPUS. (See Section 3.2 above for definitions.) Note, NGS is currently developing new versions of OPUS which may shorten the required GPS observation sessions and may fulfill Blue-Booking requirements. Any updates in this SOW's OPUS requirements will be included in the Project Instructions. Non-CORS Survey data shall be processed using standard techniques, including adjustment. All raw and processed data shall be submitted with formats and file naming conventions explained. The software used for data processing shall be pre-approved by NGS, but NGS software PAGES, ADJUST, etc. are not required to be used.

As of January 2007, NGS has released a new version of OPUS called OPUS-RS, see: <http://www.ngs.noaa.gov/OPUS/OPUS-RS.html> . OPUS-RS may be used to position all ground photo control and check points. Use two independent, 15-minute sessions for this work. See all the guidance at: http://www.ngs.noaa.gov/OPUS/OPUS-RS_More.html. Report the "Quality Indicators" for each session.

10. QUALITY CONTROL - The Contractor shall prepare and use a written Quality Control Plan, with a section on Photo Control. The Plan shall be supplied to NGS at the beginning of the project. The section shall include all phases of this work. NGS requires that all manually collected data be checked (e.g. Heights of Instruments (HI)) and recommends that all manually recorded and manually computer entered data be checked.

11. GROUND CONTROL REPORT - The Report shall include a discussion of:

- Project Identifier and location,
- Purpose,
- Firm and individuals performing work,
- Methodologies used (stop-and-go GPS, etc.),
- Equipment used (including model and serial numbers),
- Software used (including name and versions),
- Data processing,
- Data, raw and processed,
- Data formats and file naming convention,
- NOAA Form 76-53, "Control Station Identification", for each photo control point,

- Recovery Notes for survey marks used,
- Whether or not any data was submitted in “Blue-Book” format,
- A listing of all stations recovered using NGS’ On-line “Mark Recovery Form,”
- photographs of points surveyed, paper and digital copies,
- Accuracy,
- Unusual circumstances,
- Equipment malfunctions,
- A statement as to whether or not the work meets the SOW and Project Instructions, and recommendations,
- the NGS Visibility Obstruction Diagram” and the NGS “GPS Station Observation Log” may be used but are not required.

Any work not meeting specifications must be fully discussed in the report, including dates of prior communication with NGS.

If Ground Surveys under Attachment P were also performed, submit one combined report.

ANNEX A

SPECIFICATIONS FOR PREMARKING CONTROL STATIONS Revised November 23, 1976

ARRAY NO. 1

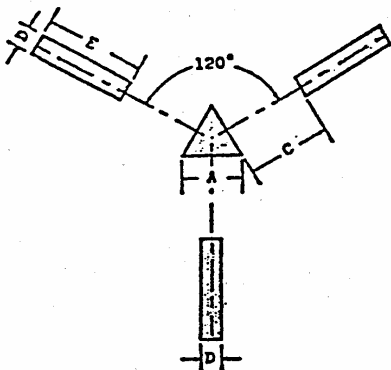

ARRAY NO. 2

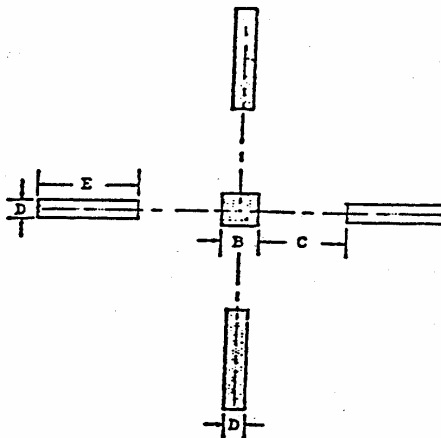

NOTE:

1. The dimensions and centering of center panel over station or substitute station are critical.
2. Panel array No. 1 is preferred but No. 2 is acceptable.
3. Array No. 3 - for contrast in very light colored areas. The border surrounding center panel and the recognition panels shall be black.
4. Chief of party will select array that makes best application of field conditions and is authorized to adjust or omit one of the recognition panels if terrain is not suitable for placement of entire array.

ARRAY NO. 3

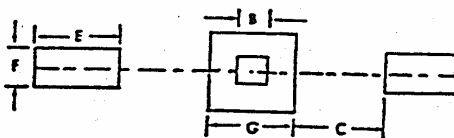

Photography Scale	PANEL AND SPACING DIMENSIONS (IN METERS)						
	A	B	C	D	E	F	G
1:10:000	0.5	0.3	1.3	0.2	0.9	0.9	1.5
1:20,000	1.1	0.7	2.6	0.4	1.8	0.9	1.9
1:30,000	1.6	1.0	3.9	0.5	2.7	0.9	2.2
1:40,000	2.2	1.3	5.2	0.7	3.6	0.9	2.5
1:50,000	3.2	2.0	7.8	1.1	5.4	1.8	3.8
1:60,000	3.8	2.3	9.1	1.3	6.3	1.8	4.1
1:70,000	4.4	2.6	10.4	1.4	7.2	1.8	4.4
1:80,000	5.0	3.0	11.7	1.5	8.0	1.8	4.8

Version 2
February 20, 2007

**ATTACHMENT P
GROUND SURVEYS V2A**

NATIONAL GEODETIC SURVEY
NATIONAL OCEAN SERVICE
NATIONAL OCEANIC AND ATMOSPHERIC ADMINISTRATION
U.S. DEPARTMENT OF COMMERCE

TABLE OF CONTENTS

ATTACHMENT P: <u>GROUND SURVEYS</u>	PAGE
1. INTRODUCTION.....	3
1.1 CHECK POINTS.....	3
1.2 GROUND CONTROL.....	3
1.3 AIRBORNE KINEMATIC GPS (KGPS) USED.....	3
1.4 NGS FORMS.....	3
2. CONTROL RECOVERY.....	3
2.1 CORS TIES.....	3
2.2 SURVEY MARK TIES.....	3
2.3 MARK DESCRIPTIONS & RECOVERY NOTES.....	3
2.4 CARE OF RECOVERY.....	4
2.5 NGS DATASHEETS.....	4
2.6 SURVEY DISKS.....	4
2.7 INTERSECTION STATIONS.....	4
3. SURVEY METHODS	4
3.1 CONVENTIONAL SURVEY POSITIONING TECHNIQUES.....	4
3.2 GPS SURVEY POSITIONING TECHNIQUES.....	5
3.3 FINDING CORS.....	5
3.4 FINDING 2 ND -ORDER OR BETTER STATIONS.....	5
3.5 GPS TIES TO TIDAL BENCH MARKS.....	5
4. VISIBILITY OBSTRUCTION DIAGRAMS & MARK RUBBINGS.....	6
4.1 VISIBILITY OBSTRUCTION DIAGRAMS.....	6
4.2 PENCIL RUBBINGS.....	6
5. GPS OBSERVATION LOGS.....	6
6. CONTROL STATION FORM.....	6
7. PHOTOGRAPHS AND MAPS.....	7
8. DATA PROCESSING.....	7
9. QUALITY CONTROL.....	7
10. GROUND CONTROL REPORT.....	8
ANNEX A – PROJECT SUBMISSION CHECKLIST.....	9

ATTACHMENT P: GROUND PHOTO CONTROL

1. INTRODUCTION - Ground surveys may be required to extend control into a project area and thereby ensure connection to the National Spatial Reference System (NSRS). See Attachment O for photo ground control requirements. Blue-booking (entering data into NGS' data entry format), is required for Ground Surveys.

1.1. CHECK POINTS - The four or more check points required by the SOW and described in Attachment O, Section 1.1 shall be connected to any Ground Surveys performed.

1.2. GROUND PHOTO CONTROL - Ground photo control surveyed for this project (see Attachment O) shall be connected to any Ground Surveys performed.

1.3 NGS FORMS – The required forms and photographs are listed in Attachment Q, Introduction.

2 CONTROL RECOVERY - All surveys shall be tied to the National Spatial Reference System (NSRS) using at least two points, CORS and/or survey marks. The specified datums are NAD 83 and NAVD 88.

2.1. CORS TIES - NGS recommends that all surveys be tied to the NSRS by using the CORS system. If a CORS is used, no recovery is required for the CORS. See the CORS map on the NGS www page at: <http://www.ngs.noaa.gov/CORS/>

2.2. SURVEY MARK TIES - If the NSRS tie is done through survey marks, the marks shall be at least second-order horizontal and third-order vertical, and digital recovery notes are required. NSRS survey marks may be found in the NGS database at: <http://www.ngs.noaa.gov/cgi-bin/datasheet.prl>

2.3. MARK DESCRIPTIONS AND MARK RECOVERY

A. Mark Descriptions - All new survey marks shall be set to NGS standards, see Attachments T, U, and V. In addition, the contractor shall write a digital description in NGS format using NGS software WDDPROC or WINDESC, see Attachment S. Digital photographs are required, see Attachment R.

B. Mark Recovery - When performing Ground Surveys, the contractor shall write a digital recovery note using NGS software WDDPROC or WINDESC for all NSRS survey marks recovered (including those recovered under Attachment O). The NGS on-line recovery method may not be used. Digital photographs are required, see Attachment R.

2.4. CARE OF RECOVERY - Recovery of survey marks shall be done with the utmost care to provide accurate information. The description of an existing station shall be carefully evaluated and checked with ground details, and the distances and directions to reference marks should be

checked. This will help ensure that the mark found is in fact the station being searched for and not a replacement station, a reference mark, an azimuth mark, or a nearby mark set by another agency with the same or similar name. The stamping and the agency name must agree exactly with the datasheet from the NGS database. See Attachment N for drawings of different types of survey disks used by this agency. Note that azimuth marks and the main triangulation station have the same stamping, just different words factory stamped or cast into the disk ("AZIMUTH MARK" or "TRIANGULATION STATION").

2.5. NGS DATASHEETS - Datasheets can be downloaded from the NGS WWW site at: <http://www.ngs.noaa.gov/cgi-bin/datasheet.prl> by clicking on "DATASHEETS", then on "Radial Search". Enter the approximate latitude and longitude, scroll down to "Horizontal Order-2 or better", and then click on "Submit Query". GPS connections may also be made to PACS (scroll down the list), which are located at many airports. The NGS database may also be searched by station name, Permanent Identifier (PID), etc. Datasheets should be downloaded at the beginning of each project to ensure that the most recent data is available. See sample in Attachment Q. Data sheets for CORS may be found at: <http://www.ngs.noaa.gov/CORS/> and then click on "DOWNLOADS", then on "Standard Files", and then on "Data Sheet".

2.6. SURVEY DISKS - NGS and its parent organization NOS and its predecessor organization USC&GS have used many different letter castings on disks. To help eliminate erroneous mark recoveries, review the drawings of these many disk styles in Attachment N. Note, the letters cast or stamped into a disk generally include the agency name and the type of disk (reference mark, azimuth mark, etc.), and are produced during the manufacture of the disk. These letters are different from the designation (name) and year stamped by the surveyor when the mark is set. Disk stampings shall not be altered at any time.

2.7. INTERSECTION STATIONS - Intersection stations such as stacks, tanks, navigational aids, and radio masts may be used to establish an azimuth, but must have an azimuth check since they are subject to erroneous recovery. Such structures may be demolished and rebuilt close to but not in exactly the same location, or structures of similar appearance may exist in the same vicinity. The recovery of such stations should be verified not only by visiting the station site but also by questioning local officials. Note, on-line recovery notes are not allowed for Intersection Stations, but WDDPROC or WINDESC recoveries are allowed.

3 SURVEY METHODS - Either conventional or GPS surveying techniques may be used to connect the surveys to the NSRS.

3.1. CONVENTIONAL SURVEY POSITIONING TECHNIQUES - If conventional techniques are used, survey methods utilizing leveling, traverse, triangulation, and/or trilateration may be used. Surveys should result in horizontal accuracies of 0.05 meters, and vertical accuracies of 0.1 meters, or better. All surveys shall have an observational check including closing position and closing azimuth checks for horizontal surveys and an elevation check for vertical surveys.

3.2. GPS SURVEY POSITIONING TECHNIQUES - If GPS techniques are used, static GPS

techniques with dual frequency GPS receivers shall be used. Each new point shall be occupied twice. All surveys should be connected to the NSRS via connections to CORS. NGS recommends observing two independent, 2-hour sessions for distances less than 50 miles (longer times for increased distances), collecting data at 15 second epochs, and using a 15 degree elevation mask. Connections should be made to the nearest NGS CORS, or if none available, to the nearest two NGS NSRS second-order or better stations. Connections shall also be made to two NGS bench marks, within 50 miles, if possible. For additional information on geodetic quality GPS observations see:

<http://www.ngs.noaa.gov/AERO/aerospecs.htm#vol1> , and

<http://www.ngs.noaa.gov/PROJECTS/FBN/>. Note: the CORS map on the NGS web page shows “National CORS” and “Cooperative CORS.” The data for the former are in the NGS database, the latter data are not. Cooperative CORS operators hold their own data and are only required to hold data for 30 days. Download data as soon as possible, especially if the collection rate was one second. **Weather data is not required**, and weather (meteorological) data is not available for CORS.

3.3. FINDING CORS - CORS may be found by visiting the NGS WWW homepage at: <http://www.ngs.noaa.gov/> and clicking on “CORS”. Note: the CORS map on the NGS web page shows “National CORS” and “Cooperative CORS.” The data for the former are in the NGS database, the latter data are not. Cooperative CORS operators hold their own data and are only required to hold data for 30 days. Download data as soon as possible, especially if the collection rate was one second.

3.4. FINDING SECOND-ORDER OR BETTER STATIONS - NSRS second-order or better stations may be found in the NGS database by visiting the NGS WWW Homepage at: <http://www.ngs.noaa.gov/> , then clicking on “DATASHEETS”, then on “Radial Search”. Enter the approximate latitude and longitude, scroll down to “Horizontal Order-2 or better”, and then click on “Submit Query”. GPS connections may also be made to PACS (next item down the scroll list), which are located at many airports.

For additional information, see “Geometric Geodetic Accuracy Standards and Specifications for Using GPS Relative Positioning Techniques”, Version 5.0, dated May 11, 1988, reprinted with corrections August 1, 1989 and “NAVSTAR GPS Surveying”, USACE, 1996.

3.5 GPS TIES TO TIDAL BENCH MARKS – A GPS tie to a tidal bench mark should consist of two, independent sessions, each four hours or more in length. See additional specifications in Section 3.2 above.

4 VISIBILITY OBSTRUCTION DIAGRAMS AND MARK RUBBINGS

4.1 VISIBILITY OBSTRUCTION DIAGRAMS - These diagrams shall be prepared for each station to depict any trees, buildings, mountains, wires, or other obstructions which may interfere with the GPS line-of-sight satellite signals. These diagrams are useful during processing to explain signal losses, multipath, or radio-interference. To fill out or check this form, use a magnetic compass to measure bearings and an inclinometer to measure vertical angles to obstructions. Sketch the surrounding obstructions as seen from the antenna viewpoint. The diagram depicts a "fish-eye" or "bubble view" of the sky over the antenna. The edges of the circle are the horizon, and the center of the circle is zenith. The NGS "Visibility Diagram" is available in Attachment Q, and a digital version at: <http://www.ngs.noaa.gov/PROJECTS/FBN/>

4.2 PENCIL RUBBINGS - The contractor shall capture a pencil rubbing of a marks' stamping (disk or logo cap) each time the mark is occupied for observations. Use the form found at: <http://www.ngs.noaa.gov/PROJECTS/FBN/> (Click on Forms," and then click on "Pencil Rubbing Form"). When not feasible to make the required rubbing, a sketch of the mark shall be substituted accurately recording all markings. Photographs are not required at each occupation.

5 GPS OBSERVATION LOGS - GPS Logs shall be used to record all equipment, activities, and other metadata associated with a GPS observing session. Please be very careful and thorough when filling out this form. GPS receivers and antennas must be uniquely identified by manufacturer, model names and numbers, and complete serial numbers. The antenna setup and height measurements must be explicitly described, using sketches and photographs if possible. All height measurements shall be checked. Any non-standard conditions shall be noted and explained. To ensure that all entries are correct, have another person check all data on the log and sign the bottom of the form as "Checked by" with their full name. The NGS "GPS Station Observation Log" is available in Attachment Q and the digital version at: <http://www.ngs.noaa.gov/PROJECTS/FBN/> . See Attachment Q for form requirements, sample forms (blank and filled-in), and sample ground photographs.

Also, see <http://www.ngs.noaa.gov/PROJECTS/FBN/> for instructions on correctly measuring GPS antenna heights. Weather data is not required.

6 CONTROL STATION FORM - Control Station Identification (CSI) (NOAA Form 76-53) is not required.

7 PHOTOGRAPHS AND MAPS - While at the site, three digital photographs shall be taken of each permanent mark, and two photographs shall be taken of each panel, and/or photo identifiable point used.

TABLE OF DIGITAL PHOTOGRAPH REQUIREMENTS

	Permanent Marks	Photo Control Points
Close-Up	V, Stamping legible	not required
Eye-Level	V, Mark & vicinity	H, vicinity
Eye-Level	H, show obstruction(s)	H, vicinity

V = vertical camera line-of-sight

H = horizontal camera line-of-sight

For horizontal view photos, show the mark in the foreground (with tripod in place, if possible) and the nearest obstruction or feature, such as trees, roads, bridges, telephone poles and buildings in the background. See Attachment R for detailed specifications.

For photographs of photo control points, the two horizontal views shall show the photo point from two different angles, with the tripod in place, if possible. Photo and file naming conventions are not required for photo points.

Place a sign in each photo (except the close-up) showing the name of the mark, panel, or point (may use a white board and heavy marker).

In addition, the location of each panel, photo identifiable point, and survey mark used shall be marked on a large scale map or chart of the area. See Attachment Q for samples of both.

8 DATA PROCESSING - Survey ties using CORS data should be processed using the On-line Positioning User Service (OPUS), see: <http://www.ngs.noaa.gov/OPUS/>. The OPUS www site states that at least two hours of data is required. When OPUS is run, the default is that OPUS uses only National CORS. Cooperative CORS may be selected manually within OPUS. (See Section 2.3 above for definitions.) Non-CORS Survey data shall be processed using standard techniques, including adjustment (NGS recommends software PAGES and ADJUST). All raw and processed data shall be submitted with formats and file naming conventions explained. See list of required files in Attachment O, Annex A.

Note, NGS is currently (mid-year 2005) developing new versions of OPUS which may shorten the required GPS observation sessions and may fulfill Blue-Booking requirements. Any updates in this SOW's OPUS requirements will be included in the Project Instructions.

9 QUALITY CONTROL - The Contractor shall prepare and use a written Quality Control Plan. The Plan shall be supplied to NGS at the beginning of the project. The plan shall include all phases of this work. NGS requires that all manually collected data be checked (e.g. Heights of Instruments (HI)) and recommends that all manually recorded and manually computer entered

data be checked.

10 GROUND CONTROL REPORT - The Report shall include a discussion of:

- Project Identifier and location,
- Purpose,
- Firm and individuals performing work,
- Methodologies used (static GPS, etc.),
- Equipment used (including model and serial numbers),
- Software used (including name and versions),
- Data processing,
- Data, raw and processed,
- Data formats and file naming convention,
- WDDPROC or WINDESC format Descriptions and Recovery Notes,
- "Blue-Book" required files (see Attachment O, Annex A),
- photographs of points surveyed, paper and digital copies,
- Accuracy,
- Unusual circumstances,
- Equipment malfunctions,
- A statement as to whether or not the work meets the SOW and Project Instructions, and Recommendations,
- NGS Visibility Obstruction Diagrams",
- NGS "GPS Station Observation Log".

Any work not meeting specifications must be fully discussed in the report, including dates of prior communication with NGS. If photo control under Attachment O was also performed, submit one combined report.

ANNEX A - PROJECT SUBMISSION CHECKLIST - GPS PROJECTS

Project Title: _____
 Accession Number: _____
 Submitting Agency: _____
 Observing Agency: _____
 Receiver Type: _____

PACKAGE CONTENTS

<u>Project Report and Attachments</u>	<u>Required For</u>
() Project Report	All Projects
() Approved Reconnaissance and Project Sketch	All Projects
() Project Instructions or Contract Specifications	All Projects
() Final Station List	All Projects
() Station Visibility Diagrams	All Projects
() Final Observing Schedule	All Projects
() Observation Logs	All Projects
() Equipment Failure Logs	NGS Projects
() Loop Misclosures	Optional
() Free Adjustment with Analysis	All Projects
() Free Adjustment with Accuracies	All Projects
() Constrained Horizontal Adjustment	All Projects
() Constrained Vertical Adjustment (NAVD 88 Heights)	All Projects
() Meteorological Instrument Comparison Logs	If Specified
() Photographs of Views from Stations	If Specified
() Photographs or Rubbings of Station Marks	All Projects
() COMPGB Output (Validation program-B/G file)	All Projects
() OBSDES Output (Validation program-D-file)	All Projects
() OBSCHK Output (Validation program-D-file)	All Projects
() CHKDESC Output (Validation program-D-file)	All Projects
() ELLACC Output	All Projects
() BBACCUR Output	All Projects

Digitized Data Files () Diskettes () Other: _____

() Raw Phase Data (R-files)	All Projects
() Base Line Vectors (G-file)	All Projects
() Project and Station Occupation Data (Final B-file)	All Projects
() Descriptions or Recovery Notes (D-file)	All Projects
() Terrestrial Horizontal Observations (T-file)	If Applicable
() Differential Leveling Observations (L-file)	If Applicable

Comments - Enter on the reverse side of this form.

	Org Code	Name	Date
Received by:	_____	_____	_____
Reviewed by:	_____	_____	_____
Reviewed by:	_____	_____	_____

Version 3
February 20, 2007

**ATTACHMENT Q
HORIZONTAL CONTROL FORMS**

TO
SCOPE OF WORK FOR GROUND SURVEYS

NATIONAL GEODETIC SURVEY
NATIONAL OCEAN SERVICE
NATIONAL OCEANIC & ATMOSPHERIC ADMINISTRATION
U.S. DEPARTMENT OF COMMERCE

ATTACHMENT Q - HORIZONTAL CONTROL FORMS

Q1. WDDPROC printout of NGS Station Description (1p)

To download, see: http://www.ngs.noaa.gov/PC_PROD/DDPROC4.XX/ddproc.index.html

Q2. "Mark Recovery Entry" form on NGS WWW site (blank)

Q3. "Mark Recovery Entry" form on NGS WWW site (filled in sample)

For entries on-line, see: <http://www.ngs.noaa.gov/> and scroll to bottom of page.

Q4. NGS Station Description/Recovery Form (Short paper version, 2p), (blank)

Q5. NGS Station Description/Recovery Form (Short paper version, 2p), (filled-in sample)

For on-line versions (blank and filled-in) see: <http://www.ngs.noaa.gov/PROJECTS/FBN/>

Q6. NGS - GPS Observation Log (Info. at time of GPS observations, 2p), (blank)

Q7. NGS - GPS Observation Log (Info. at time of GPS observations, 2p), (filled-in sample)

For on-line versions (blank and filled-in) see: <http://www.ngs.noaa.gov/PROJECTS/FBN/>

Q8. NGS Visibility Obstruction Diagram (GPS satellite visibility, 1p), (blank)

Q9. NGS Visibility Obstruction Diagram (GPS satellite visibility, 1p), (filled-in sample)

For on-line versions (blank and filled-in) see: <http://www.ngs.noaa.gov/PROJECTS/FBN/>

Q10. Station Pencil Rubbing Form (blank)

Q11. Station Pencil Rubbing Form (filled-in sample)

For on-line versions (blank and filled-in) see: <http://www.ngs.noaa.gov/PROJECTS/FBN/>

Q12. "Station Location Sketch and Visibility Diagram" (New), (blank)

Q13. "Station Location Sketch and Visibility Diagram" (New), (filled in sample)

For on-line versions (blank and filled-in) see: <http://www.ngs.noaa.gov/PROJECTS/FBN/>

Q14. Control Station Identification (NOAA Form 76-53)(Photo panel desc. and sketch, 1p), blank

Q15. Control Station Identification (NF 76-53)(Photo panel desc. and sketch, 1p), filled-in

Above form is not available on-line, but is included on CD with SOW.

Q16. Three Digital Photographs - For samples of the three required digital photographs, see Attachment R.

Q17. Two Digital Photographs - Sample photos of check points, photo control panels, and photo control ID points (13 sample photos).

Q18. Sample map showing flight lines, survey points, and approximate photo panel locations.

Q19. NGS Data Sheet printout of survey station (Sample output from NGS database, 2p)

To search for a data sheet, see: <http://www.ngs.noaa.gov/cgi-bin/datasheet.pr1>

Notes:

1. See Attachment R for digital ground photography specifications and samples.

2. The www sites listed above contains PDF versions of the forms which may be printed out or completed on-line.

REQUIREMENTS FOR SHORELINE MAPPING PROJECTS

REQUIRED TYPE SURVEY	WDDPROC (FORM Q1) OR WINDESC	NGS WWW ON-LINE REC FORM Q2-3	STATION DESC/ RECOVERY FORM FORM Q4-5	NGS GPS OBSERVA LOG FORM Q6-7	VISIBILITY DIAGRAM FORM Q8-9	PENCIL RUBBING Q10-11	CONTROL STATION ID. (NF 76-53) Q14-15	3 DIGITAL PHOTOS Q16	2 DIGITAL HORIZONTAL PHOTOS Q17	PROJECT AREA MAP Q18
NEW GROUND BASE STATION (MK SET)	YES	-----	RECOM.	YES	YES	AT EACH OBSERVA	-----	YES	-----	YES
NEW GROUND BASE STATION (TEMP PT)	-----	-----	-----	YES	YES	AT EACH OBSERVA	YES	-----	YES	YES
GROUND BASE STA. (EXISTING MARK)	-----	YES	RECOM.	YES	YES	AT EACH OBSERVA	-----	YES	-----	YES
CHECK POINT	-----	-----	-----	RECOM.	RECOM.	-----	YES	-----	YES	YES
PHOTO CONTROL PT	-----	-----	-----	RECOM.	RECOM.	-----	YES	-----	YES	YES
GROUND SURVEY PT (BLUE-BOOK PROJECT)	YES	-----	RECOM.	YES	YES	AT EACH OBSERVA	-----	YES	-----	YES

Notes:

1. All NSRS stations found will be recovered using WDDPROC or WINDESC (for Blue-Book projects), or using the NGS on-Line “Mark Recovery Entry” system.
2. The new “Station Location Sketch and Visibility Diagram” form (three windows + page 2) may be used to replace the “Visibility Diagram,” the “Pencil Rubbing,” and the “Station Description/Recovery” forms.
3. See Attachment R for digital photograph requirements.

***** O R I G I N A L D E S C R I P T I O N *****

 SSN: 0002
 Designation: MAGO
 PID:
Approx. Latitude: 441042N State: MI
Approx. Longitue: 0862159W County: MANISTEE
Approx. Elevation: 162.9M Disk From:
 Stamping: MAGO

Surface Mark-

 Type: Survey disk
Magnetic code: N
 Setting: SURROUNDED BY A MASS OF CONCRETE
Rod depth: Sleeve Depth:

***Mark is suitable for GPS

Set by NOS in 1993, Chief of party ALG.

THE STATION IS LOCATED 4.0 MI (6.4 KM) WEST OF MANISTEE,
MICHIGAN, IN THE NORTHWEST QUADRANT OF 'THE INTERSECTIONS OF
COUNTY LINE ROAD AND RED APPLE ROAD.

TO REACH FROM THE INTERSECTION OF U.S. HIGHWAY 31 AND COUNTY LINE
ROAD AT THE MANISTEE-MASON COUNTY LINE, GO WEST ON COUNTY LINE
FOR 3.3 MI (5.3 KM) TO A ROAD RIGHT JUST BEFORE THE END OF THE
PAVED ROAD SURFACE AND THE STATION ON THE RIGHT IN A GRASSY RIGHT
OF WAY IN THE NORTHEAST QUADRANT OF THE INTERSECTION OF COUNTY
LINE ROAD AND RED APPLE ROAD.

THE STATION IS 43.0 FT (13.1 M) NORTH OF A DEAD END SIGN, 47 FT
(14.3 M) NORTHWEST OF A STOP SIGN, 57.0 FT (17.4 M) WEST OF
CENTERLINE OF RED APPLE ROAD AND 62.0 FT (18.9 M) NORTH OF
CENTERLINE OF COUNTY LINE ROAD.

Mark Recovery Entry

This form can be used to submit recovery information for survey marks to the National Geodetic Survey. If the data sheet for this mark shows a recovery within the past 12 months and the status has not changed, please do not report it.

Enter PID:

Select condition of mark:

- Good
- Not recovered, not found
- Poor, disturbed, mutilated, requires maintenance

For Destroyed condition, see **Note** below

Note: For destroyed marks do one of the following:

1) If you have found the actual marker separated from its setting, you can report the point as destroyed. To do so please send the report on the destroyed mark as an email to Deb Brown (Deb.Brown@noaa.gov). If you send this email, please do not submit the current form, Deb Brown will submit the report for you. **In addition, please submit proof of the mark's destruction via actual disk, rubbing, photo, or digital picture (preferred) to Deb Brown:**

Deb Brown, N/NGS143
National Geodetic Survey, NOAA
1315 East West Highway
Silver Spring, MD 20910

2) If you did not find the actual marker, then you should enter notes concerning evidence of its possible destruction as text records and select "Not recovered, not found" as the condition of mark.

Enter agency code of the recovering organization/agency:

- USPSQD - U.S. Power Squadron
- INDIV - Local Surveyor or Engineer
- NGS - National Geodetic Survey
- Other - Enter the approved agency code of the organization which recovered the mark in the textbox below.

If you do not know your approved agency code, you can generate the latest contributors' list from NGS'

integrated database (NGSIDB). On this list the agency code starts in column 1 and the agency full name follows it. The list is sorted alphabetically by agency code. If your agency or firm is not on this list and you would like to be assigned a specific agency code, please contact Deb Brown at NGS to make the appropriate arrangements.

Enter initials of the person who recovered the mark (Optional):

The date of recovery must be expressed as a numerical month (between 1 and 12), a numerical day of the month, and a four character numerical year. The month, day, and year may be separated by spaces or by commas.

Valid examples are:

4,25,1998 for April 25, 1998

4 25 1998 for April 25, 1998

The current program is not valid for dates before 1990.

Enter date of recovery:

Enter your name and email address:

Privacy Statement: Your name and email address will be used only to contact you if there is a problem in loading your recovery. They will not be used for any other purpose.

Enter name:

Enter email address:

You can, if you wish, enter up to 15 lines of text in the space below. The only characters that are allowed are: letters, numbers, blank or space (), comma (,), period or decimal (.), apostrophe or single quote ('), asterisk (*), plus sign (+), minus sign or hyphen (-), equal sign (=), slash (/), left parenthesis ((), and right parenthesis ()).

Warning: Do not enter personal phone numbers.

Note: Text such as RECOVERED AS DESCRIBED, or MARK NOT FOUND, or DESCRIPTION IS ADEQUATE, etc. is not necessary.

Mark Recovery Entry

This form can be used to submit recovery information for survey marks to the National Geodetic Survey. If the data sheet for this mark shows a recovery within the past 12 months and the status has not changed, please do not report it.

Enter PID:

Select condition of mark:

- Good
 Not recovered, not found
 Poor, disturbed, mutilated, requires maintenance

For Destroyed condition, see **Note** below

Note: For destroyed marks do one of the following:

1) If you have found the actual marker separated from its setting, you can report the point as destroyed. To do so please send the report on the destroyed mark as an email to Deb Brown (Deb.Brown@noaa.gov). If you send this email, please do not submit the current form, Deb Brown will submit the report for you. **In addition, please submit proof of the mark's destruction via actual disk, rubbing, photo, or digital picture (preferred) to Deb Brown:**

Deb Brown, N/NGS143
National Geodetic Survey, NOAA
1315 East West Highway
Silver Spring, MD 20910

2) If you did not find the actual marker, then you should enter notes concerning evidence of its possible destruction as text records and select "Not recovered, not found" as the condition of mark.

Enter agency code of the recovering organization/agency:

- USPSQD - U.S. Power Squadron
 INDIV - Local Surveyor or Engineer
 NGS - National Geodetic Survey
 Other - Enter the approved agency code of the organization which recovered the mark in the textbox below.

If you do not know your approved agency code, you can generate the latest contributors' list from NGS' integrated database (NGSIDB). On this list the agency code starts in column 1 and the agency full name

follows it. The list is sorted alphabetically by agency code. If your agency or firm is not on this list and you would like to be assigned a specific agency code, please contact Deb Brown at NGS to make the appropriate arrangements.

Enter initials of the person who recovered the mark (Optional):

The date of recovery must be expressed as a numerical month (between 1 and 12), a numerical day of the month, and a four character numerical year. The month, day, and year may be separated by spaces or by commas.

Valid examples are:

4,25,1998 for April 25, 1998

4 25 1998 for April 25, 1998

The current program is not valid for dates before 1990.

Enter date of recovery:

Enter your name and email address:

Privacy Statement: Your name and email address will be used only to contact you if there is a problem in loading your recovery. They will not be used for any other purpose.

Enter name:

Enter email address:

You can, if you wish, enter up to 15 lines of text in the space below. The only characters that are allowed are: letters, numbers, blank or space (), comma (,), period or decimal (.), apostrophe or single quote ('), asterisk (*), plus sign (+), minus sign or hyphen (-), equal sign (=), slash (/), left parenthesis ((), and right parenthesis ()).

Warning: Do not enter personal phone numbers.

Note: Text such as RECOVERED AS DESCRIBED, or MARK NOT FOUND, or DESCRIPTION IS ADEQUATE, etc. is not necessary.

MARK RECOVERED AS DESCRIBED, EXCEPT A NEW FENCE IS NOW 6 METERS WEST OF THE STATION.	<input type="text"/>
--	----------------------

For assistance contact Deb Brown

--> Click here to clear the sample data <--

NATIONAL GEODETIC SURVEY STATION DESCRIPTION / RECOVERY FORM

4-char ID: _____ Designation: _____

PID: _____ Alias: _____

Country: (USA / _____) State: _____ County: _____

Latitude: N _____ ° _____ ' _____ " Longitude: W _____ ° _____ ' _____ " Elevation: _____ (meter / ft)

Original Description (check one):	
<input type="checkbox"/> P	Preliminary (mark has not been set yet)
<input type="checkbox"/> D	A newly set mark
<input type="checkbox"/> R	A recovered mark
Established by: (NGS / CGS / Other:)	
Date: _____	Chief of Party (initials): _____

Recovery Description (check one):	
<input type="checkbox"/> F	Full description of a station <i>not</i> in the database
<input type="checkbox"/> T	Full description of a station <i>in</i> the database
<input type="checkbox"/> M	<i>Partial</i> description of a station in the database
Recovered by: (NGS / Other:)	
Date: _____	Chief of Party (initials): _____

Monument Stability (check one):	
<input type="checkbox"/> A	Of the most reliable nature; expected to hold well
<input type="checkbox"/> B	Will probably hold position and elevation well
<input type="checkbox"/> C	May hold well, but subject to ground movement
<input type="checkbox"/> D	Of questionable or unknown reliability

Recovery Condition (check one):	
<input type="checkbox"/> G	Recovered in good condition
<input type="checkbox"/> N	Not recovered or not found
<input type="checkbox"/> P	Poor, disturbed, or mutilated
<input type="checkbox"/> X	Surface mark known destroyed

Setting Information:	
Marker Type: (Rod / Disk / Other)	
Setting Type: (Bedrock / Concrete / Other:)	
Y / N / ?	Monument contains magnetic material?

Stamping:	
Agency Inscription: (NGS / CGS / Other:)	
Rod Depth: _____ (m/ft)	Sleeve Depth: _____ (m/ft)
Monument is: (flush / projecting / recessed) _____ (cm/ft)	

Special Type (check all applicable):	
<input type="checkbox"/> F	Fault monitoring site
<input type="checkbox"/> T	Tidal Station
<input type="checkbox"/> --	Control Station: (FBN / CBN / Bench mark)
<input type="checkbox"/> --	Airport Control Station: (PACS / SACS)
Y / N	Mark is suitable for GPS use?

Transportation (check one):	
<input type="checkbox"/> C	Car
<input type="checkbox"/> P	Light truck (pickup, carry-all, etc.)
<input type="checkbox"/> X	Four-Wheel Drive Vehicle
<input type="checkbox"/> _	Other (SnowCat, Plane, Boat; describe)
Y / N	Pack Time (hike) to mark? (hh:mm):

See Back of Form to add Text Description

General Station Location: The station is located in _____

_____ (Describe general location; include airline distances to three towns or mapped features.)

Ownership: _____
_____ (name, address, phone of landowner)

To Reach Narrative: To reach the station from the intersection of _____

_____ (Leg-by-leg distances and directions from major road intersection to mark)

Monument Description and Measurements: The station is _____

_____ (Add at least three measurements to permanent, identifiable, nearby objects; and a description of the monument size, shape, height, etc.)

NOTE: - Include a pencil rubbing, sketch, or photographs of mark.

Described by: _____ Phone: (_____) _____ e-mail: _____

NATIONAL GEODETIC SURVEY STATION DESCRIPTION / RECOVERY FORM

4-char ID: BALD Designation: BALD 2 RESET

PID: QE2736 Alias: _____

Country: (USA / USA) State: OR County: LINCOLN

Latitude: N 44 49 49.17802 " Longitude: W 124 03 56.23447 " Elevation: 17.0 (meter / ft)

Original Description (check one):	
<input type="checkbox"/> P	Preliminary (mark has not been set yet)
<input type="checkbox"/> D	A newly set mark
<input checked="" type="checkbox"/> R	A recovered mark
Established by: (NGS / CGS / Other:) <u>Oregon DOT</u>	
Date:	Chief of Party (initials): <u>???</u>

Recovery Description (check one):	
<input type="checkbox"/> F	Full description of a station <i>not</i> in the database
<input checked="" type="checkbox"/> T	Full description of a station <i>in</i> the database
<input type="checkbox"/> M	<i>Partial</i> description of a station in the database
Recovered by: (NGS / Other:) <u>Oregon DOT</u>	
Date:	Chief of Party (initials): <u>CFS</u>

Monument Stability (check one):	
<input checked="" type="checkbox"/> A	Of the most reliable nature; expected to hold well
<input type="checkbox"/> B	Will probably hold position and elevation well
<input type="checkbox"/> C	May hold well, but subject to ground movement
<input type="checkbox"/> D	Of questionable or unknown reliability

Recovery Condition (check one):	
<input checked="" type="checkbox"/> G	Recovered in good condition
<input type="checkbox"/> N	Not recovered or not found
<input type="checkbox"/> P	Poor, disturbed, or mutilated
<input type="checkbox"/> X	Surface mark known destroyed

Setting Information:	
Marker Type: (Rod / <input checked="" type="checkbox"/> Disk / Other)	
Setting Type: (Bed <input checked="" type="checkbox"/> rock / Concrete / Other:)	
<input checked="" type="checkbox"/> / N / ?	Monument contains magnetic material?

Stamping:	<u>BALD 2 1991</u>	
Agency Inscription: (NGS / CGS / Other:)	<u>Oregon DOT</u>	
Rod Depth:	(m/ft)	Sleeve Depth: (m/ft)
Monument is: (<input checked="" type="checkbox"/> flush / projecting / recessed)	(cm/ft)	

Special Type (check all applicable):	
<input type="checkbox"/> F	Fault monitoring site
<input type="checkbox"/> T	Tidal Station
<input checked="" type="checkbox"/> --	Control Station: (FBN / <input checked="" type="checkbox"/> CBN / Bench <input checked="" type="checkbox"/> mark)
<input type="checkbox"/> --	Airport Control Station: (PACS / SACS)
<input checked="" type="checkbox"/> /N	Mark is suitable for GPS use?

Transportation (check one):	
<input checked="" type="checkbox"/> C	Car
<input type="checkbox"/> P	Light truck (pickup, carry-all, etc.)
<input type="checkbox"/> X	Four-Wheel Drive Vehicle
<input type="checkbox"/> _	Other (SnowCat, Plane, Boat; describe)
<input checked="" type="checkbox"/> /N	Pack Time (hike) to mark? (hh:mm): <u>00:03</u>

See Back of Form to add Text Description

General Station Location: The station is located in about 10 km south from Lincoln Bay, 13 km north from Depoe Bay, and at the US101 Boiler Bay wayside rest area.

(Describe general location; include airline distances to three towns or mapped features.)

Ownership: The station is on the property of Oregon State Department of Parks and Recreation.

(name, address, phone of landowner)

To Reach Narrative: To reach the station from the intersection of US routes 5 and 101 in Depoe Bay, go north on US 101 for 1 km to the south entrance of the Boiler Bay wayside. Bear left on entrance road for 0.4 km to the parking area on the left. Park northwest inside fence for about 90 meters to end of fence and the station on the right.

(Leg-by-leg distances and directions from major road intersection to mark)

Monument Description and Measurements: The station is set into drill hole in bedrock, 7.6 m south from the north fence corner, 8.8 m east from the west fence corner, and 3.6 m southeast from the northwest end of the outcrop.

(Add at least three measurements to permanent, identifiable, nearby objects; and a description of the monument size, shape, height, etc.)

NOTE: - Include a pencil rubbing, sketch, or photographs of mark.

Described by: John Q. Surveyor Phone: (301)713-3194 e-mail: jqs@ordot.gov

--> Click here to clear the sample data <--

	Station Designation: (check applicable: __ FBN __ CBN __ PAC __ SAC __ BM)	Station PID, if any:	Date (UTC):
	General Location: Airport ID, if any:	Station 4-Character ID:	Day of Year:
Project Name:	Project Number: GPS-	Station Serial # (SSN):	Session ID:(A,B,C etc)

NAD83 Latitude o . "	NAD83 Longitude o . "	NAD83 Ellipsoidal Height meters	Agency Full Name: Operator Full Name: Phone # () e-mail address:
Observation Session Times (UTC): Sched. Start _____ Stop _____		NAVD88 Orthometric Ht. meters	
Actual Start _____ Stop _____		GEOID99 Geoid Height meters	

Receiver Brand & Model: P/N: S/N: Firmware Version: <input type="checkbox"/> CamCorder Battery, <input type="checkbox"/> 12V DC, <input type="checkbox"/> 110V AC, <input type="checkbox"/> Other	Antenna Code*, Brand & Model: P/N: S/N: Cable Length, meters: Vehicle is Parked _____ meters _____(direction) from antenna.	Antenna plumb before session? (Y/N) Circle Yes or No Antenna plumb after session? (Y/N) -if no, explain Antenna oriented to true North? (Y/N) Weather observed at antenna ht. (Y/N) Antenna ground plane used? (Y/N) "
--	--	--

Tripod or Antenna Mount: Check one: <input type="checkbox"/> Fixed-Leg Tripod, <input type="checkbox"/> Collapsible-leg tripod <input type="checkbox"/> Fixed Mount Brand & Model: P/N: S/N: Last Adjustment date: Psychrometer (if used) Brand & Model: P/N: S/N: Last Calibration or check Date:	** ANTENNA HEIGHT **				
	A= Datum point to Top of Tripod (Tripod Height)	Before Session Begins: Meters	Before Session Begins: Feet	After Session Ends: Meters	After Session Ends: Feet
	B= Additional offset to ARP if any (Tribrach/Spacer)				
	H= Antenna Height = A + B = Datum Point to Antenna Reference Point (ARP)				

Barometer (if used) Brand & Model: S/N:	Weather Data	Weather Codes	Time (UTC)	Dry-Bulb Temp Fahrenheit Celsius	WetBulb Temp Fahrenheit Celsius	Rel. % Humidity	Atm. Pressure inches Hg millibar
	Before						
	Middle						
	After						

Remarks, Comments on Problems, Sketches, Pencil Rubbing, etc:

Calculate

Weather codes are required. Weather data are optional but encouraged. *Antenna code comes from ant_info file furnished by project coordinator.

Data File Name(s): (Standard NGS Format = aaaaddds.xxx) where aaaa=4-Character ID, ddd=Day of Year, s=Session ID, xxx=file dependant extension	Updated Station Description: <input type="checkbox"/> Attached <input type="checkbox"/> Submitted earlier Visibility Obstruction Form: <input type="checkbox"/> Attached <input type="checkbox"/> Submitted earlier Photographs of Station: <input type="checkbox"/> Attached <input type="checkbox"/> Submitted earlier Pencil Rubbing of Mark: <input type="checkbox"/> Attached	LOG CHECKED BY:
---	---	-----------------

Table of Weather Codes	CODE	PROBLEM	VISIBILITY	TEMPERATURE	CLOUD COVER	WIND
	0	did not occur	Good, over 15 miles	Normal, 32° F- 80°F	Clear, below 20%	Calm, under 5mph (8km/h)
	1	did occur	Fair, 7-15 miles	Hot, over 80°F (27 C)	Cloudy, 20% to 70%	Moderate, 5 to 15 mph
	2	- not used -	Poor, under 7 miles	Cold, below 32° F (0 C)	Overcast, over 70%	Strong, over 15 mph (24km/h)

Examples: 00000 = No problem, good visibility, normal temp, clear, calm wind 12121 = Problems, poor visibility, hot, overcast, moderate wind

 <p>GPS STATION OBSERVATION LOG April 16, 2003</p>	Station Designation: (check applicable: ___ FBN ___ CBN ___ PAC ___ SAC ___ <input checked="" type="checkbox"/> BM) BALD 2 RESET	Station PID, if any: QE2736	Date (UTC): 31 Dec 2002	
	General Location: Boiler Bay Wayside Airport ID, if any: ---	Station 4-Character ID: BALD	Day of Year: 365	
Project Name: Sample GPS, 2002		Project Number: GPS- 1234	Station Serial # (SSN): leave blank	Session ID:(A,B,C etc) A

NAD83 Latitude 44 49 49.17802	NAD83 Longitude 124 03 56.23447	NAD83 Ellipsoidal Height -6.44 meters	Agency Full Name: Oregon DOT Operator Full Name: John Q. Surveyor Phone # () (301) 713-3194 e-mail address: jqs@ordot.gov
Observation Session Times (UTC): Sched. Start 12:00 Stop 17:30		NAVD88 Orthometric Ht. 17.0 meters	
Actual Start 11:55 Stop 17:32		GEOID99 Geoid Height -23.52 meters	

Receiver Brand & Model: Leica SR530 p/n 667122 s/n 0030354 Firmware Version: Version 3.0	Antenna Code*, Brand & Model: Trimble Choke Ring p/n 29659-00 s/n 02200-63591 Cable Length, meters: 30 meters	<input checked="" type="checkbox"/> Antenna plumb before session? (Y/N) Circle Yes or No <input checked="" type="checkbox"/> Antenna plumb after session? (Y/N) -if no, explain <input checked="" type="checkbox"/> Antenna oriented to true North? (Y/N) <input checked="" type="checkbox"/> Weather observed at antenna ht. (Y/N) <input checked="" type="checkbox"/> Antenna ground plane used? (Y/N) <input type="checkbox"/> Antenna radome used? (Y/N) If yes, describe. <input type="checkbox"/> Eccentric occupation (>0.5 mm)? (Y/N) Use <input type="checkbox"/> Any obstructions above 10'? (Y/N) Use <input type="checkbox"/> Radio interference source nearby (Y/N) Vis. form
<input checked="" type="checkbox"/> CamCorder Battery, <input type="checkbox"/> 12V DC, <input type="checkbox"/> 110V AC, <input type="checkbox"/> Other Vehicle is Parked <u>25</u> meters <u>N</u> (direction) from antenna.		

Tripod or Antenna Mount: Check one: <input checked="" type="checkbox"/> Fixed-Leg Tripod, <input type="checkbox"/> Collapsible-leg tripod <input type="checkbox"/> Fixed Mount Brand & Model: SECO P/N: none. S/N: 97-G Last Adjustment date: 2002-11-01 Psychrometer (if used) Brand & Model: P/N: Psychrodyne S/N: J.Q.S. Last Calibration or check Date:	** ANTENNA HEIGHT **		Before Session Begins:		After Session Ends:	
		Meters	Feet	Meters	Feet	
	A= Datum point to Top of Tripod (Tripod Height)	2.000		2.000		
	B= Additional offset to ARP if any (Tribrach/Spacer)	-0.003		-0.003		
	H= Antenna Height = A + B = Datum Point to Antenna Reference Point (ARP)					
Meters = Feet x (0.3048) Note &/or sketch ANY unusual conditions. Height Entered Into Receiver = <u>2.000</u> meters. Be Very Explicit as to where and how Measured!						

Barometer (if used) Brand & Model: pretel altiplus A2	Weather Data	Weather Codes	Time (UTC)	Dry-Bulb Temp		WetBulb Temp		Rel. % Humidity	Atm. Pressure	
				Fahrenheit	Celsius	Fahrenheit	Celsius		inches Hg	millibar
S/N: J.Q.S. none. 01-Nov-02	Before	00000	12:00	74.0		68.0		74	29.44	
	Middle	00001	14:45	77.0		72.5		81	29.55	
	After	00102	17:30	82.5		78.0		82	29.66	

Remarks, Comments on Problems, Sketches, Pencil Rubbing, etc:

Calculate

1. Winds, calm at start, gradually increased to 20 knots by end of session.

2. Semi-trailer parked 12 meters SSE of antenna from 15:17 to 15:32 UTC, possibly blocking satellites and causing multipath environment.

Weather codes are required. Weather data are optional but encouraged. *Antenna code comes from ant_info file furnished by project coordinator.

Data File Name(s): BALD365A.dat <small>(Standard NGS Format = aaaadddd.xxx) where aaaa=4-Character ID, ddd=Day of Year, s=Session ID, xxx=file dependant extension</small>	Updated Station Description: <input checked="" type="checkbox"/> Attached <input type="checkbox"/> Submitted earlier Visibility Obstruction Form: <input checked="" type="checkbox"/> Attached <input type="checkbox"/> Submitted earlier Photographs of Station: <input checked="" type="checkbox"/> Attached <input type="checkbox"/> Submitted earlier Pencil Rubbing of Mark: <input checked="" type="checkbox"/> Attached	LOG CHECKED BY: JGE
--	---	-------------------------------

Table of Weather Codes	CODE	PROBLEM	VISIBILITY	TEMPERATURE	CLOUD COVER	WIND
	0	did not occur	Good, over 15 miles	Normal, 32° F- 80°F	Clear, below 20%	Calm, under 5mph (8km/h)
1	did occur	Fair, 7-15 miles	Hot, over 80°F (27 C)	Cloudy, 20% to 70%	Moderate, 5 to 15 mph	
2	- not used -	Poor, under 7 miles	Cold, below 32° F (0 C)	Overcast, over 70%	Strong, over 15 mph (24km/h)	

Examples: 00000 = No problem, good visibility, normal temp, clear, calm wind 12121 = Problems, poor visibility, hot, overcast, moderate wind

ILLUSTRATION FOR ANTENNA HEIGHT MEASUREMENTS:

I. Instructions for Fixed-Height Tripods:

Measure & record the fixed-height tripod length (A) and other offsets, if any, between the tripod and the Antenna Reference Point (ARP) (B)

$$\text{Antenna Height} = H = A + B$$

II. Instructions for Slip-Leg Tripods:

1. Measure the Slant Height (S)

Measure the slope distance from the mark to at least three notches on the Bottom of Ground Plane (BGP) using two independent rulers (e.g., metric and Imperial). Record measurements in the table below, and compute the average.

Measure S	Notch #_	Notch #_	Notch #_	Average
Before, cm	223.40	223.30	223.30	
Before, inch	87.95	87.94	87.93	
After, cm	223.40	223.40	223.30	
After, inch	87.97	87.96	87.95	
Note: cm= inch x (2.54)		Overall average, cm		

$$S = \text{_____ cm}$$

2. Record the Antenna Radius (R) and the Antenna Constant (C)

The antenna radius (R) is the horizontal distance from the center of the antenna to the measurement notch. The antenna constant (C) is the vertical distance from the ARP to the BGP. Consult your antenna users manual for exact measurements.

$$R = \text{19.05 cm}$$

$$C = \text{3.50 cm}$$

3. Compute Antenna Height (H)

Use the following Pythagorean equation:

$$\text{Antenna Height} = H = ((\sqrt{S^2 - R^2}) - C)$$

$$\text{Antenna Height} = H = a + b$$

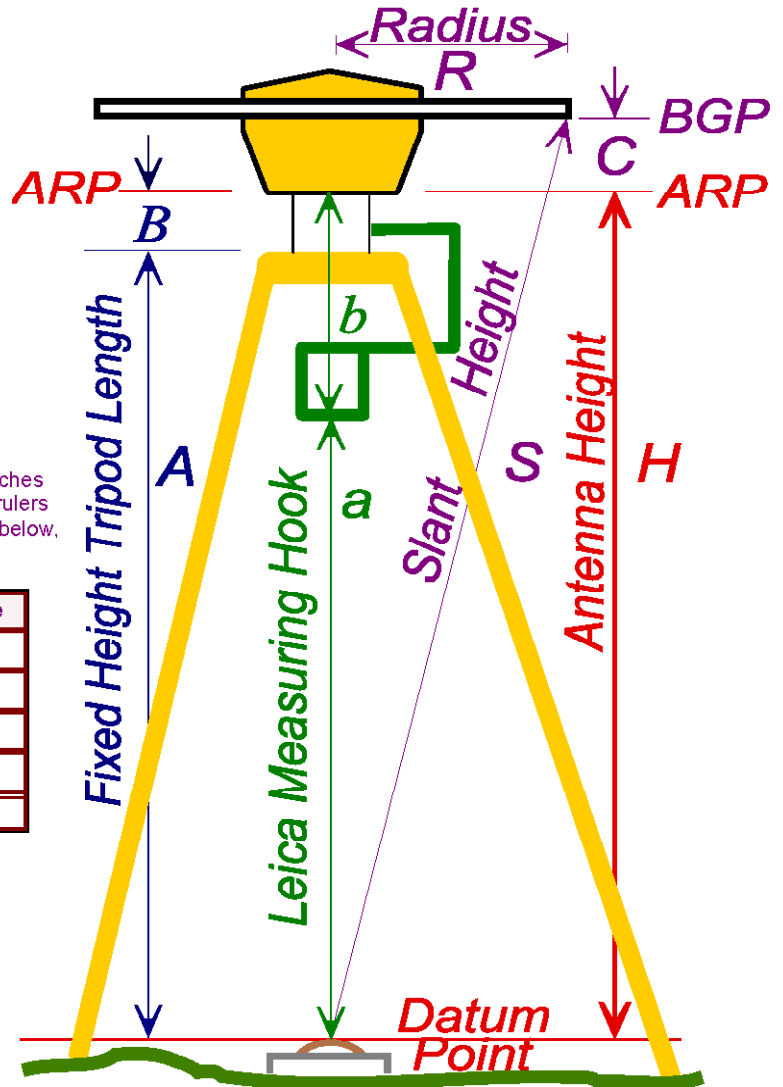

III. Instructions for using the Leica Brand Measuring Hook:

Follow the Leica operating instructions, being sure to reduce the height to the Antenna Reference Point (ARP), NOT the L1 Phase Center.

Table of Weather Codes -- for entry into Weather Data Table on front of form:

CODE	PROBLEM	VISIBILITY	TEMPERATURE	CLOUD COVER	WIND
0	NO PROBLEMS encountered	GOOD More than 15 miles	NORMAL 32° F to 80° F	CLEAR Below 20%	CALM Under 5mph (8km/h)
1	PROBLEMS encountered	FAIR 7 to 15 miles	HOT Over 80° F (27 C)	CLOUDY 20% to 70%	MODERATE 5 to 15 mph
2	-- NOT USED --	POOR Less than 7 miles	COLD Below 32° F (0 C)	OVERCAST Over 70%	STRONG over 15mph (24km/h)
Examples: Code 00000 = 0 - No problems, 0 - good visibility, 0 - normal temperature, 0 - clear sky, 0 - calm wind					
Code 12121 = 1 - Problems, 2 - poor visibility, 1 - hot temperature, 2 - overcast, 1 - moderate wind					

[--> Click here to clear the sample data <--](#)

NATIONAL GEODETIC SURVEY VISIBILITY OBSTRUCTION DIAGRAM

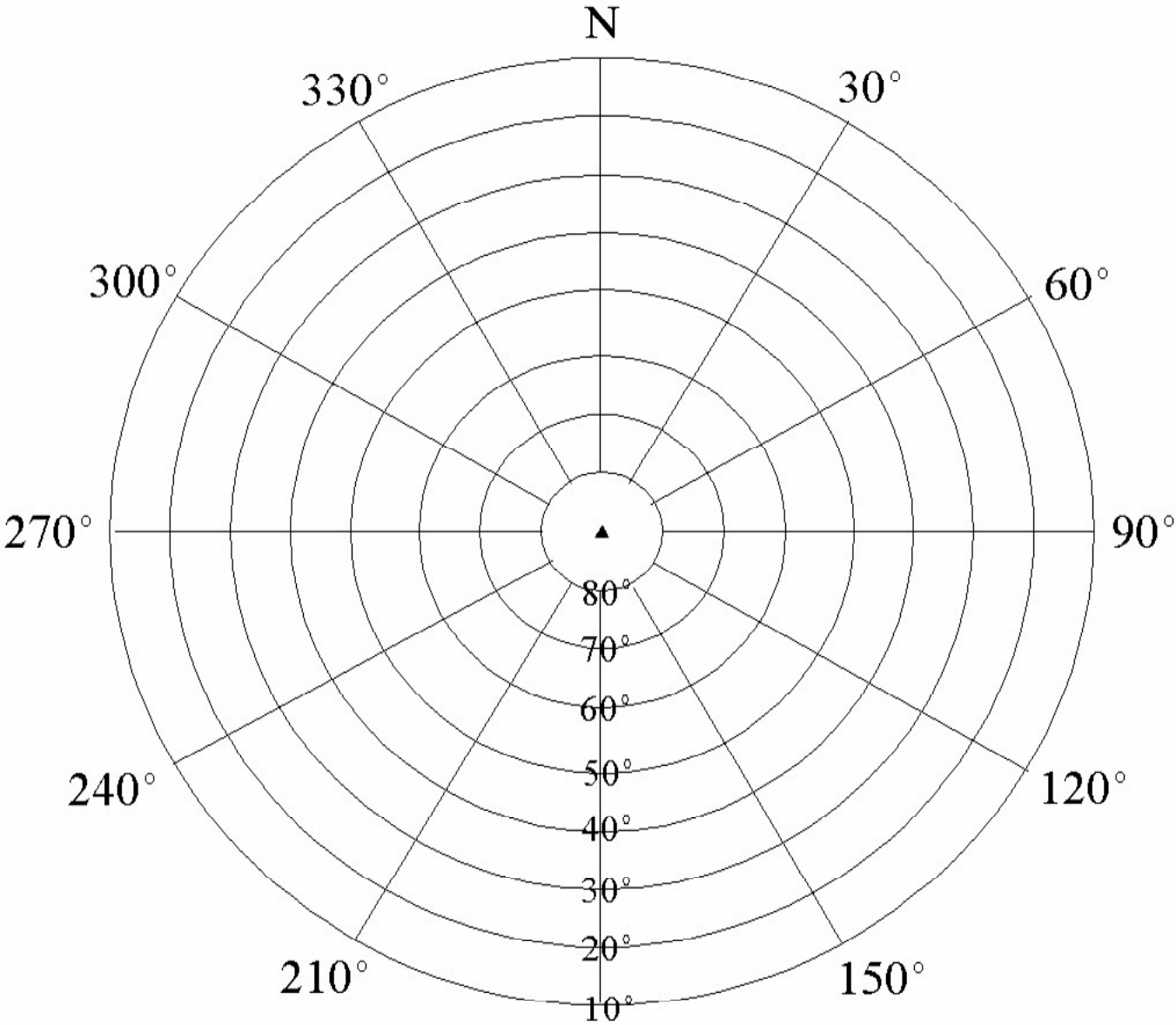

INSTRUCTIONS:

Identify obstructions by azimuth (magnetic) and elevation angle (above horizon) as seen from station mark. Indicate distance and direction to nearby structures and reflective surfaces (potential multipath sources).

4-char ID: _____ Designation: _____

PID: _____ Location: _____

County: _____ Reconnaissance By: _____

Height above mark, meters: _____ Agency/Company: _____

Phone: (_____) _____ Date: _____

Check if no obstructions above 10 degrees

--> Click here to clear the sample data <--

NATIONAL GEODETIC SURVEY VISIBILITY OBSTRUCTION DIAGRAM

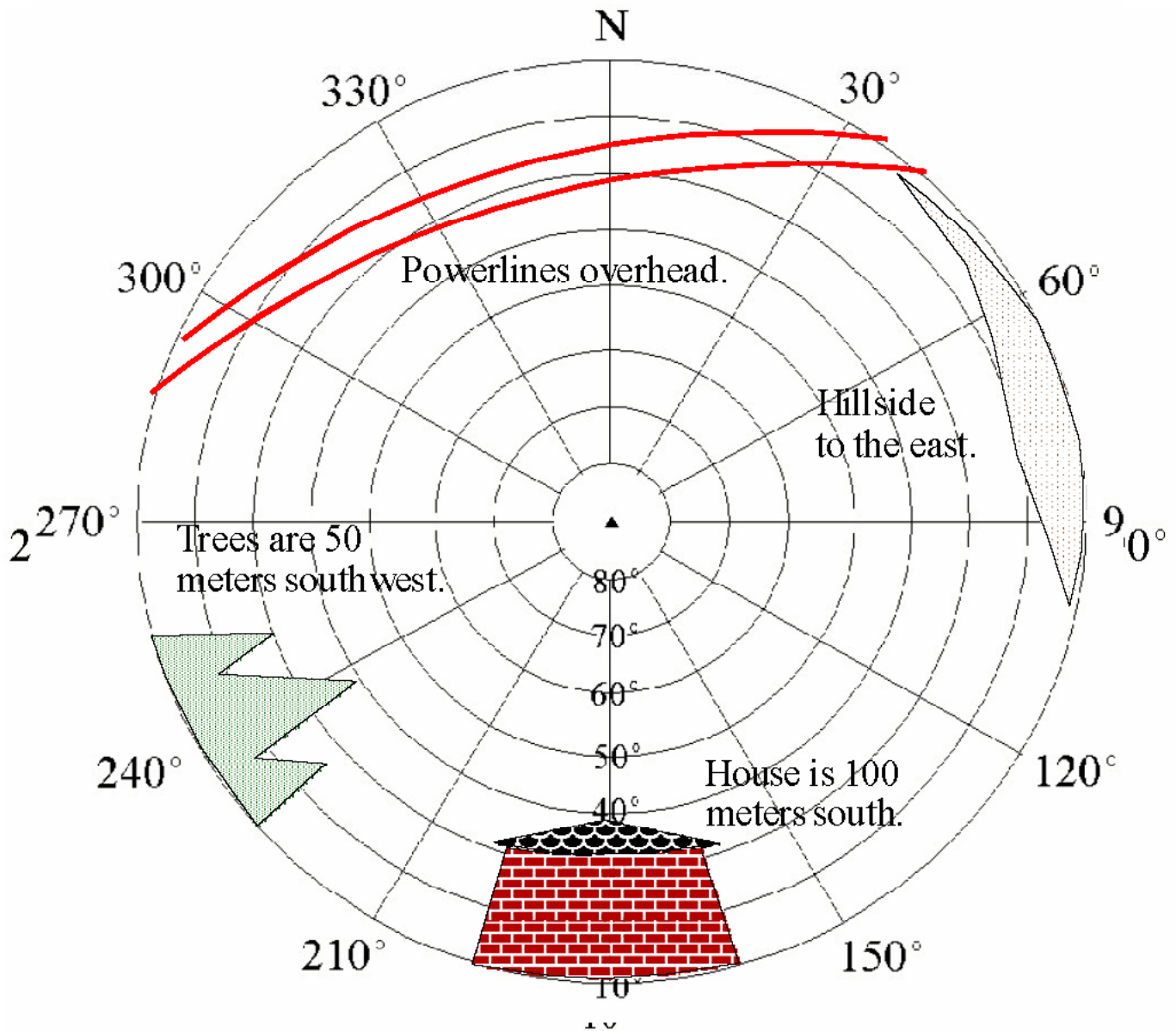

INSTRUCTIONS:

Identify obstructions by azimuth (magnetic) and elevation angle (above horizon) as seen from station mark. Indicate distance and direction to nearby structures and reflective surfaces (potential multipath sources).

4-char ID: BALD Designation: BALD 2 RESET

PID: QE2736 Location: Boiler Bay Wayside

County: LINCOLN Reconnaissance By: John Q. Surveyor

Height above mark, meters: 2 Agency/Company: Oregon DOT

Phone: () (301) 713-3194 Date: 1998-12-31

Check if no obstructions above 10 degrees

[--> Click here to clear the sample data <--](#)

NATIONAL GEODETIC SURVEY PENCIL RUBBING FORM

4-char ID: _____ Day of Year ("Julian Day"): _____

Designation: _____ PID: _____

Stamping: _____

Mark Type / Agency Inscription: _____

Location: _____ County: _____

Rubbing By: _____ Date: _____

Agency: _____ Phone: (____) _____

Remarks: _____

INSTRUCTIONS:

Place the blank form (or other blank paper) over the mark and rub over the entire disk with a pencil. For rod marks, rub only the designation and date stamping from the rim of the aluminum logo cap. If it is impossible to make a rubbing of the mark, or if the rubbing appears indistinct, a sketch and/or photograph may be substituted.

--> Click here to clear the sample data <--

NATIONAL GEODETIC SURVEY PENCIL RUBBING FORM

4-char ID: BALD Day of Year ("Julian Day"): 365

Designation: BALD 2 RESET PID: QE2736

Stamping: BALD 2 1991

Mark Type / Agency Inscription: Brass Disk Oregon DOT

Location: Boiler Bay Wayside County: LINCOLN

Rubbing By: John Q. Surveyor, ORDOT Date: 1998-12-31

Agency: Oregon DOT Phone: () (301) 713-3194

Remarks: This disk is reset into the same drill hole as the original station BALD 1962.

INSTRUCTIONS:

Place the blank form (or other blank paper) over the mark and rub over the entire disk with a pencil. For rod marks, rub only the designation and date stamping from the rim of the aluminum logo cap. If it is impossible to make a rubbing of the mark, or if the rubbing appears indistinct, a sketch and/or photograph may be substituted.

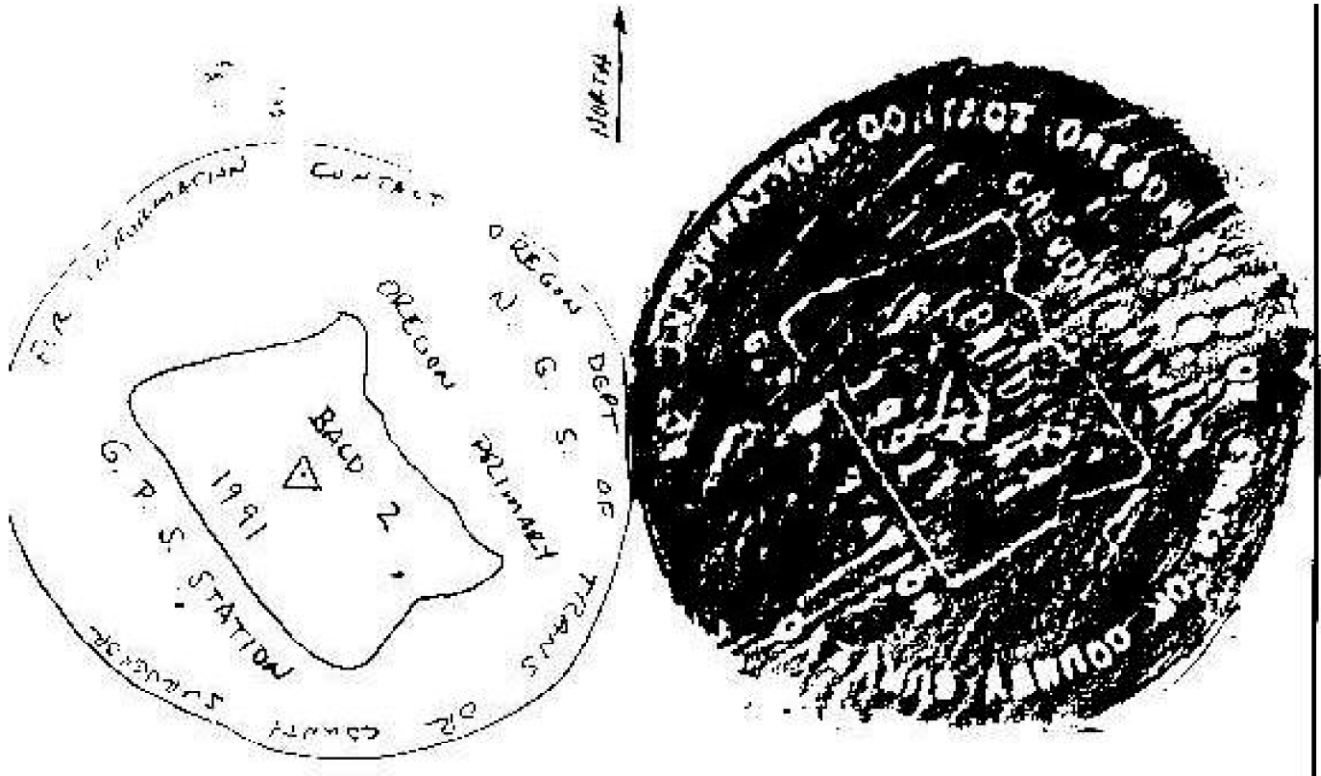



--> Click here to clear the sample data <--

Station Location Sketch and Visibility Diagram

Location / Airport Name and ID _____ Project _____

Station Designation _____ PID _____ Date _____

Circle all applicable: PACS SACS BM FBN CBN OTHER _____

Observer & Organization _____

Station Location Sketch

Sketch of Disk

- Monument Stability Quality: Photos Available
- A- Most stable
 - B- Excellent
 - C- Good
 - D- Poor

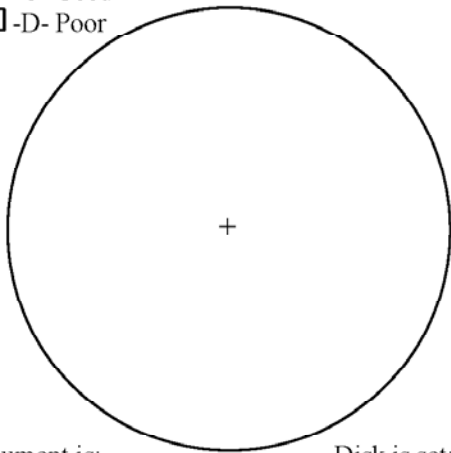

- Monument is:
- Recessed ___ cm
 - Flush with ground surface
 - Projecting ___ cm
- Disk is set:
- in bedrock.
 - in concrete.
 - in structure.

Visibility Diagram

- No Obstructions above 10° Photos Available

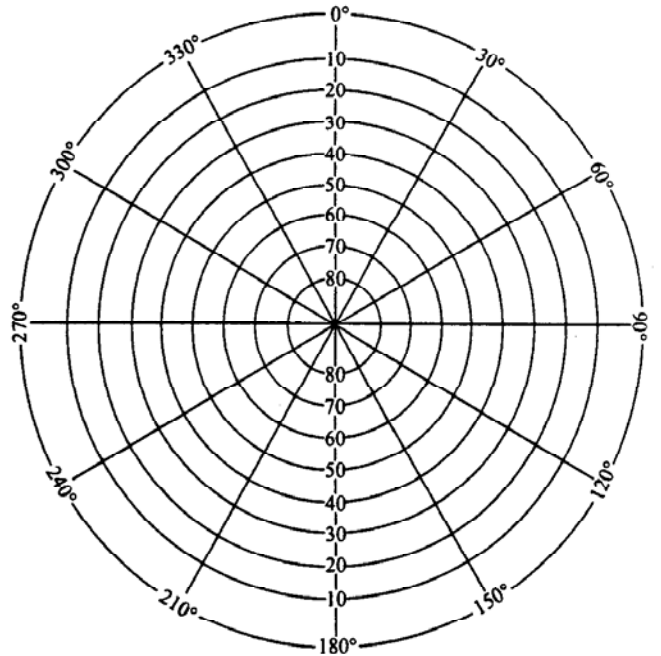

General Station Location: *"The station is located in . . .*

(Describe general location; include airline distances to three towns or mapped features.)

Ownership:

(OPTIONAL: name, address, phone of landowner)

To Reach Narrative: *"To reach the station from the intersection of . . .*

(Leg-by-leg distances and directions from major road intersection to mark.)

Monument Description and Measurements: *"The station is . . .*

(Add at least 3 measurements to permanent, identifiable, nearby objects; and a description of the monument size, shape, height, etc.)



--> Click here to clear the sample data <--

Station Location Sketch and Visibility Diagram

Location / Airport Name and ID Boiler Bay Wayside Project Sample GPS, 1998

Station Designation BALD 2 RESET PID QE2736 Date 1998-12-31

Circle all applicable: PACS SACS FM FBN OTHER Observer & Organization John Q. Surveyor

Station Location Sketch

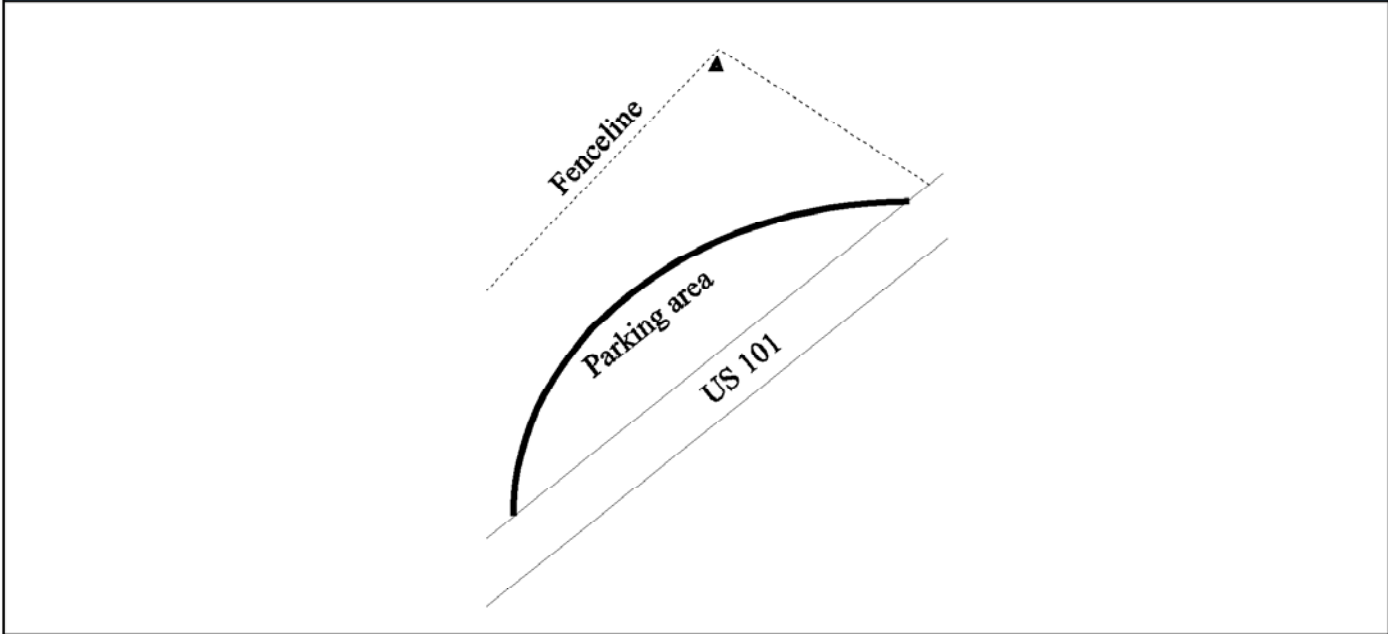

Sketch of Disk

Monument Stability Quality: -A- Most stable
 -B
 -C
 -D

Photos Available

A hand-drawn sketch of a monument disk. The disk is roughly rectangular with rounded corners. Handwritten text around the perimeter includes: 'F.R. INFORMATION CONTACT', 'OREGON N. S. DEPT. OF TRANSPORTATION', 'G.P.S. STATION BALD 2', '1991', 'MILLERS SUPPLY', 'CONTRACT', 'OREGON PRIMARY', 'N. S. DEPT. OF TRANSPORTATION'. A north arrow is drawn to the right of the sketch.

Monument is: Recessed ___ cm
 Flush with ground surface
 Projecting ___ cm

Disk is set: in bedrock.
 in concrete.
 in structure.

Visibility Diagram

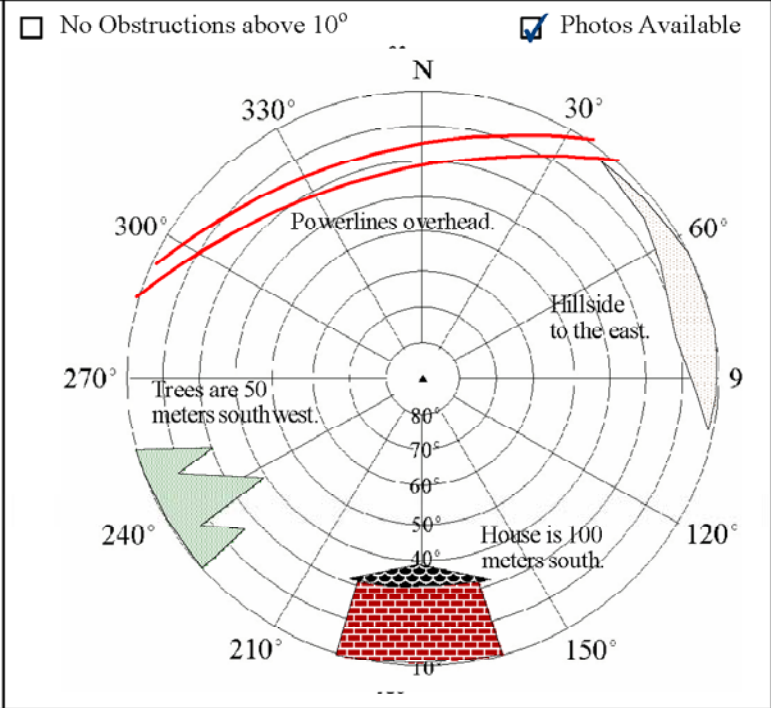

General Station Location: *"The station is located in . . . about 10 km south from Lincoln City, 13 km north from Depoe Bay, and at the US101 Boiler Bay Wayside.*

(Describe general location; include airline distances to three towns or mapped features.)

Ownership: The station is on the property of Oregon State Dept of Parks & Recreation.

(OPTIONAL: name, address, phone of landowner)

To Reach Narrative: *"To reach the station from the intersection of . . . US routes 5 and 101 in Depoe Bay, go north on US 101 for 1 km to the south entrance of the Boiler Bay wayside. Bear left on entrance road for 0.4 km to the parking area on the left. Pack northwest inside fence for about 90 meters to end of fence and the station on the right.*

(Leg-by-leg distances and directions from major road intersection to mark.)

Monument Description and Measurements: *"The station is . . . set into drill hole in bedrock, 7.6 m south from the north fence corner, 8.8 m east from the west fence corner, and 3.6 m southeast from the northwest end of the outcrop.*

(Add at least 3 measurements to permanent, identifiable, nearby objects; and a description of the monument size, shape, height, etc.)

CONTROL STATION IDENTIFICATION

STATION		CONTROL DATA REF.
STATE	COUNTY	IDENTIFIED BY
DATE	ACCURACY	CHIEF OF PARTY
MAP NUMBER	JOB NUMBER	PHOTO NUMBER

DESCRIPTION OF SUBSTITUTE STATION A	SKETCH (SUBSTITUTE STATION A)	
		
	INFORMATION REQUIRED-SUBSTITUTE STATION A	
	INST. STATION	
	AZ. STATION	
< TO STA. (RIGHT)		
DISTANCE	FT.	M.

DESCRIPTION OF SUBSTITUTE STATION B OR STATION IDENTIFIED DIRECT.	SKETCH (SUBSTITUTE STATION B)	
		
	INFORMATION REQUIRED-SUBSTITUTE STATION B	
	INST. STATION	
	AZ. STATION	
< TO STA. (RIGHT)		
DISTANCE	FT.	M.

CONTROL STATION IDENTIFICATION

STATION PANEL NO 2		CONTROL DATA REF. MAGC
STATE MICHIGAN	COUNTY MANISTEE	IDENTIFIED BY C.S. MIDDLETON JR.
DATE 6/16/93	ACCURACY	CHIEF OF PARTY A.L. GRIMES III
MAP NUMBER	JOB NUMBER CM-9303	PHOTO NUMBER

DESCRIPTION OF SUBSTITUTE STATION A
The panel consists of a standard array No. 1 for 1:40,000 of white material. It is located about 4.2 mi SSW of Manistee, 1.1 mi ENE of Lake Michigan, 1 mi South of Mayons Creek in the NW quadrant of a "T" intersection of paved roads in grassy pasture 16 meters North of the E-W road (County Line Rd) and 15 meters West of the North-South road (Red Apple Road). It is placed over real station "MAGC" postured by GPS.

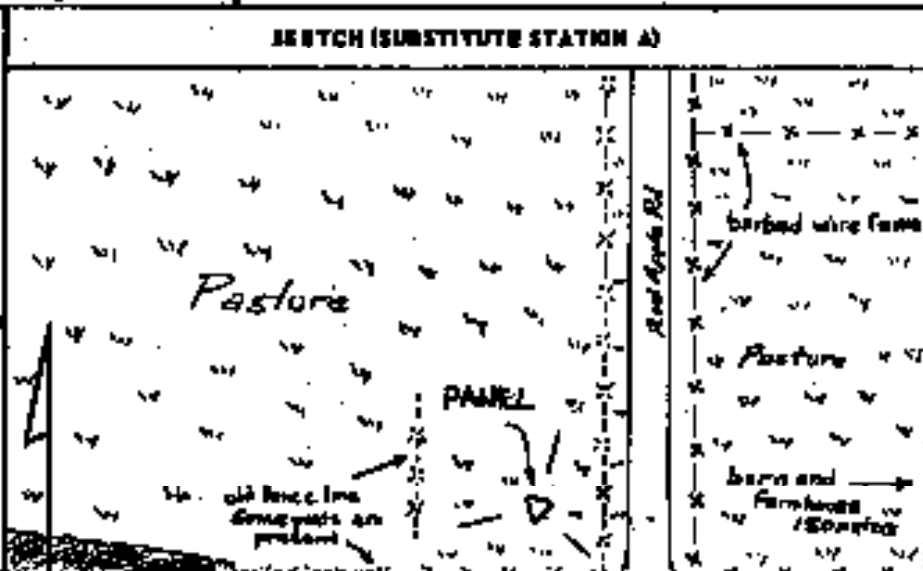

INFORMATION REQUIRED-SUBSTITUTE STATION A

INSTR. STATION		
AZ. STATION		
C TO STA. (RIGHT)		
DISTANCE	FT.	M.

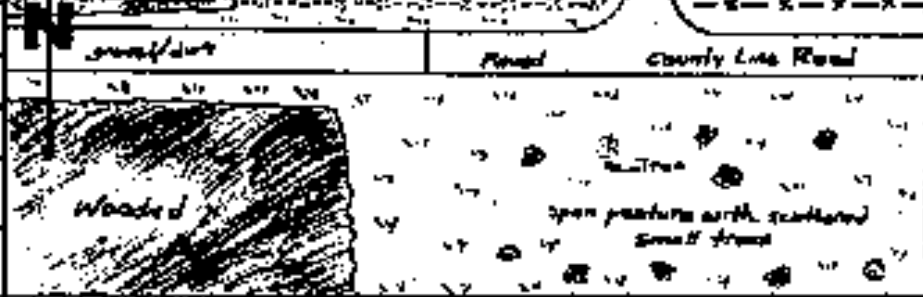

DESCRIPTION OF SUBSTITUTE STATION B OR STATION IDENTIFIED DIRECT.

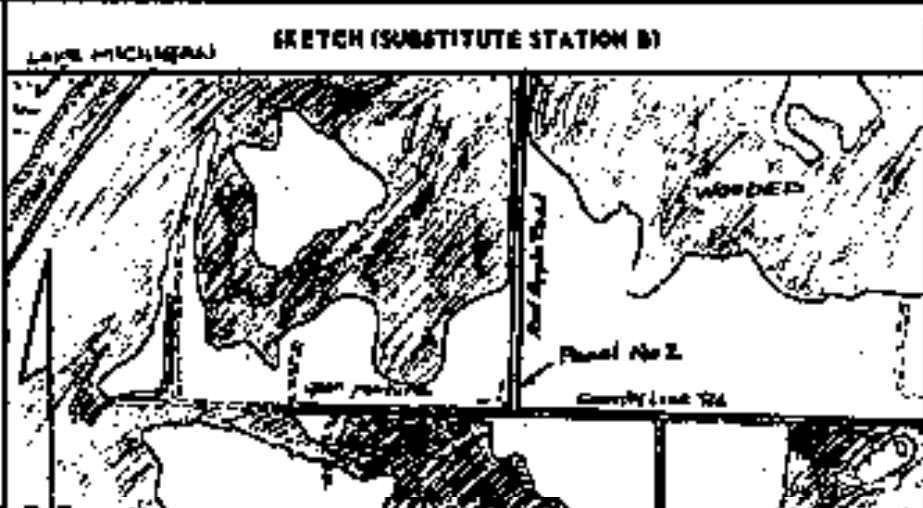

INFORMATION REQUIRED-SUBSTITUTE STATION B

INSTR. STATION		
AZ. STATION		
C TO STA. (RIGHT)		
DISTANCE	FT.	M.





LAYTON, JV4425, 1, 28 FEB 01



LAYTON

LAYTON, JV4425, 2, 28 FEB 01



LAYTON NE

LAYTON, JV4425, 3NE, 28FEB01



PT1,3NW,14JUN05



PT2,3SE,23MAY05



PT3,3SE,24JUN05



P08,3E,30OCT03



P08,3W,30OCT03



P09,3E,30OCT03



P09,3N,30OCT03



P11A,3N,30OCT03



P11A,3S,30OCT03



P12,3E,30OCT03



P12,3S,30OCT03

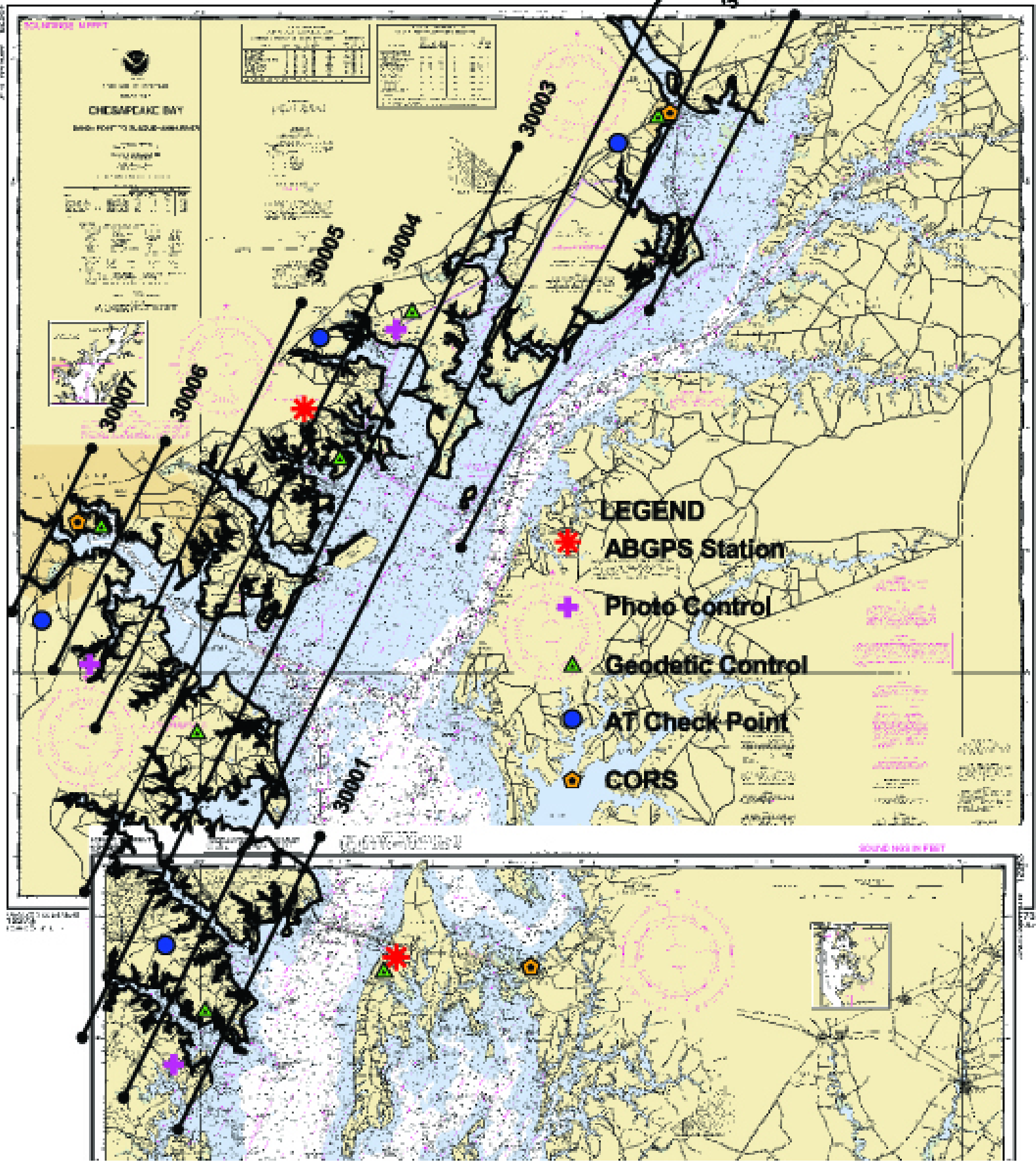

11-10-2008

11-10-2008

11-10-2008

11-10-2008

The NGS Data Sheet

See file [dsdata.txt](#) for more information about the datasheet.

```
DATABASE = Sybase ,PROGRAM = datasheet, VERSION = 6.55
1 National Geodetic Survey, Retrieval Date = NOVEMBER 1, 2001
PM0610 *****
PM0610 DESIGNATION - MAGO
PM0610 PID - PM0610
PM0610 STATE/COUNTY- MI/MANISTEE
PM0610 USGS QUAD -
PM0610
PM0610 *CURRENT SURVEY CONTROL
PM0610
PM0610* NAD 83(1994)- 44 10 42.42614(N) 086 21 59.07961(W) ADJUSTED
PM0610* NAVD 88 - 198.7 (meters) 652. (feet) VERTCON
PM0610
PM0610 X - 290,374.115 (meters) COMP
PM0610 Y - -4,572,586.816 (meters) COMP
PM0610 Z - 4,422,447.482 (meters) COMP
PM0610 LAPLACE CORR- 5.74 (seconds) DEFLEC99
PM0610 ELLIP HEIGHT- 163.48 (meters) GPS OBS
PM0610 GEOID HEIGHT- -35.11 (meters) GEOID99
PM0610
PM0610 HORZ ORDER - SECOND
PM0610 ELLP ORDER - FOURTH CLASS I
PM0610
PM0610.The horizontal coordinates were established by GPS observations
PM0610.and adjusted by the National Geodetic Survey in February 1997.
PM0610
PM0610.The NAVD 88 height was computed by applying the VERTCON shift value to
PM0610.the NGVD 29 height (displayed under SUPERSEDED SURVEY CONTROL.)
PM0610
PM0610.The X, Y, and Z were computed from the position and the ellipsoidal ht.
PM0610
PM0610.The Laplace correction was computed from DEFLEC99 derived deflections.
PM0610
PM0610.The ellipsoidal height was determined by GPS observations
PM0610.and is referenced to NAD 83.
PM0610
PM0610.The geoid height was determined by GEOID99.
PM0610
PM0610; North East Units Scale Converg.
PM0610;SPC MI C - 97,734.994 5,840,105.658 MT 1.00000112 -1 24 45.5
PM0610;UTM 16 - 4,891,888.539 550,644.965 MT 0.99963154 +0 26 29.6
PM0610
PM0610 SUPERSEDED SURVEY CONTROL
PM0610
PM0610 NAD 83(1986)- 44 10 42.43156(N) 086 21 59.08087(W) AD( ) 2
PM0610 NGVD 29 - 198.8 (m) 652. (f) GPS OBS
PM0610
PM0610.Superseded values are not recommended for survey control.
PM0610.NGS no longer adjusts projects to the NAD 27 or NGVD 29 datums.
PM0610.See file dsdata.txt to determine how the superseded data were derived.
PM0610
PM0610_MARKER: DD = SURVEY DISK
PM0610_SETTING: 4 = SURROUNDED BY MASS OF CONCRETE
```

PM0610_STAMPING: MAGO
PM0610_MARK LOGO: NOS
PM0610_MAGNETIC: N = NO MAGNETIC MATERIAL
PM0610_STABILITY: A = MOST RELIABLE AND EXPECTED TO HOLD
PM0610+STABILITY: POSITION/ELEVATION WELL
PM0610_SATELLITE: THE SITE LOCATION WAS REPORTED AS SUITABLE FOR
PM0610+SATELLITE: SATELLITE OBSERVATIONS - 1993

PM0610
PM0610 HISTORY - Date Condition Report By
PM0610 HISTORY - 1993 MONUMENTED NOS

PM0610
PM0610 STATION DESCRIPTION
PM0610

PM0610'DESCRIBED BY NATIONAL OCEAN SERVICE 1993
PM0610'THE STATION IS LOCATED 4.0 MI (6.4 KM) WEST OF MANISTEE, MICHIGAN, IN
PM0610'THE NORTHWEST QUADRANT OF THE INTERSECTIONS OF COUNTY LINE ROAD AND
PM0610'RED APPLE ROAD.
PM0610'TO REACH FROM THE INTERSECTION OF U.S HIGHWAY 31 AND COUNTY LINE ROAD
PM0610'AT THE MANISTEE-MASON COUNTY LINE, GO WEST ON COUNTY LINE FOR 3.3 MI
PM0610'(5.3 KM) TO A ROAD RIGHT JUST BEFORE THE END OF THE PAVED ROAD
PM0610'SURFACE AND THE STATION ON THE RIGHT IN A GRASSY RIGHT OF WAY IN THE
PM0610'NORTHEAST QUADRANT OF THE INTERSECTION OF COUNTY LINE ROAD AND RED
PM0610'APPLE ROAD.
PM0610'THE STATION IS 43.0 FT (13.1 M) NORTH OF A DEAD END SIGN, 47.0 FT
PM0610'(14.3 M) NORTHWEST OF A STOP SIGN, 57.0 FT (17.4 M) WEST OF
PM0610'CENTERLINE OF RED APPLE ROAD AND 62.0 FT (18.9 M) NORTH OF CENTERLINE
PM0610'OF COUNTY LINE ROAD.

*** retrieval complete.
Elapsed Time = 00:00:02

Version 13B
February 20, 2007

ATTACHMENT R
REQUIREMENTS FOR DIGITAL PHOTOGRAPHS V13b

NATIONAL GEODETIC SURVEY
NATIONAL OCEAN SERVICE
NATIONAL OCEANIC AND ATMOSPHERIC ADMINISTRATION
U.S. DEPARTMENT OF COMMERCE

TABLE OF CONTENTS

ATTACHMENT R - REQUIREMENTS FOR DIGITAL PHOTOGRAPHS

	PAGE
1. PURPOSE.....	3
2. SURVEY MARKS.....	3
2.1 NUMBER OF PHOTOGRAPHS.....	3
2.2 CAPTION.....	4
2.3 DESCRIPTION OF PHOTOGRAPHS.....	5
3. RECONNAISSANCE.....	6
3.1 PROPOSED LOCATIONS FOR MARKS.....	7
3.2 RUNWAY END PHOTOGRAPHS.....	7
3.3 NAVIGATION AIDS.....	7
3.4 DEPTH OF HOLE PHOTOGRAPHS.....	7
3.5 PHOTOGRAMMETRIC CONTROL POINTS.....	7
3.6 OTHER REQUIRED PHOTOGRAPHS.....	7
4. GENERAL.....	8
4.1 IMAGE SIZE.....	8
4.2 FILE SIZE.....	8
4.3 IMAGE FORMAT.....	8
4.4 PHOTOGRAPH FILE NAME.....	8
5. STORAGE MEDIUM.....	8
*ACRONYMS.....	8
ANNEX 1	9

ATTACHMENT R: REQUIREMENTS FOR DIGITAL PHOTOGRAPHS

1. PURPOSE - This document describes digital photographic standards for images of survey marks that will be stored in the National Geodetic Survey (NGS) database and for other reconnaissance photographs (including photo ground control). Since many of these images will be in the NGS database and available to the public, the subject matter (survey equipment, personnel, background, etc.) must be in good taste and professional in nature.

Digital photographs are useful for station (mark) reconnaissance, mark recovery, mark stability assessment, quality control, and as an aid during data processing and data verification. Some projects may require digital photographs during several stages of the project. Generally three photographs per station will be stored in the NGS database, which will make them accessible to future users. The table below summarizes the required photographs. Detailed descriptions of the photographs follow.

2. SURVEY MARK PHOTOGRAPHS - This section states the requirements for digital photographs of new and existing survey marks. For the requirements for reconnaissance photographs, including photo control points, runways, etc., see Section 3.

Take all photographs during daylight hours.

2.1. NUMBER OF SURVEY MARK PHOTOGRAPHS - At least three digital photographs are required for each mark recovered or described. This means marks for which a written, NGS format, digital description or recovery note was prepared. The three photographs are described as numbers: (1) extreme close-up, (2) eye-level (5-6 feet distant), and (3) horizontal view (approx. 10-30 feet distant). All three photographs require a digital caption and the correct file name. Photographs 2 and 3 require a **small, temporary sign** in the photograph. Use a small sign with large, clear letters (e.g. white board with dark marker). Ensure that the sign does not cover any portion of the mark, the monument, or any important feature.

REQUIRED PHOTOGRAPHS

<u>All Marks Recovered and/or Described</u>
1. Close-up (Taken Vertically; so stamping is legible)
2. Eye level (Taken Vertically; shows mark and area)
3. Horizontal view(s), mark in foreground, feature(s) in background

Take sufficient photographs to describe the stamping, appearance, condition, and location of the mark and points of potential interest including visibility obstructions, roads, runways, taxiways, or other dangers, any special set-up requirements, etc. Alter the orientation of the photographs as necessary to include this information in as few photographs as possible (For example, for a tall obstruction, rotate the camera 90 degrees so that the long axis of the image is vertical). Capture

the tops of nearby obstructions, if possible. If a station already has acceptable photographs in the NGS database, additional photographs are not required, unless changes have occurred or more than one year has passed. An “acceptable photograph” is defined as an image that meets the requirements of this document, is of good visual quality, and that no changes have taken place that a new photograph would help clarify.

2.2. CAPTION - The photographer shall write a caption for each photograph and add the caption to the image. The block containing the caption shall not cover any portion of the mark, the monument, or any important feature. The caption should contain the following comma-separated information:

- Station designation (name),
- Station Permanent IDentifier (PID), for existing stations in the NGS database, leave blank if new station,
- Airport Location IDentifier (LID), if on airport, leave blank if not on airport,
- Photo number with cardinal direction (N, NE, E, SE, etc) that the camera is pointing, note, only photo #3 has a direction
- Station type (PACS, SACS, FBN, CBN), otherwise leave blank
- Date photo was taken (yyyymmdd).

SAMPLE CAPTION FOR NEW MARK

JONES, 2, 20040825

SAMPLE CAPTION FOR PHOTO CONTROL POINT

PH1,2,20040825

SAMPLE CAPTION FOR EXISTING PACS ON AIRPORT

SMITH, AB1234, LAX, 3N, PACS, 20040825

Note, the cardinal direction should not be included on photographs 1 and 2 since they were taken vertically. Do not leave blank spaces for missing data, see JONES example above with no PID, no LID, no station type, and no extra “commas”.

The caption may be digitally captured on the image at the time of exposure or may be inserted later, off-line. Record at least the date on-line, if possible. If caption information is added later, take careful notes at the time of exposure to help ensure that the correct caption is added. **Note, the caption shall not obstruct any pertinent aspects of the station or surroundings.** To ensure that the letters of the caption are visible, use software to “erase” a rectangular area for the caption’s lettering; see samples in section 2.3 and Attachment Q.

2.3. DESCRIPTION OF PHOTOGRAPHS:

A. CLOSE-UP - For survey marks, the first photograph (photo no.1) will be a close-up, taken vertically. It will be oriented downward to show the survey mark from directly above with the disk or logo cap nearly filling the image. The tripod shall not be in place when this photograph is captured. Brush any dirt or debris off the mark to show the disk. If it has a logo cap, the logo cap should be open. The intent of this photograph is to **clearly show the mark, its condition, and all stamping on the mark or logo cap so that it is clearly legible.** Use extra care to ensure that the stamping is clear.



Suggestions: set the camera to its highest quality and resolution modes; **rub a yellow crayon across the stamping to highlight the letters;** set the camera to “macro” mode, if available; consider the minimum focusing distance of the camera (take test photographs to determine the minimum focusing distance and consult the camera owner’s manual) ; and, if a flash is used, hold the camera above and off to the side so that the flash does not create a bright spot in the middle of the disk’s image. Note, medium quality and resolution camera modes may be used for photographs other than the close-ups. If additional photographs are required, number these close-ups as 1A, 1B, etc.

B. EYE-LEVEL - For survey marks, this photograph (photo no.2) will be oriented vertically downward from eye level to show the monument from directly above and cover an area about 1 meter in radius, all around the mark. The tripod shall not be in place when this photograph is captured. Brush any dirt or debris off the mark to show the disk and the setting. If it is a concrete monument, clear off debris to the edge of the monument. If it has a logo cap, the logo cap should be open. **Include a small, temporary sign in this photograph with the station designation (name) printed so it is clearly visible in the photograph.** The intent of this photograph is to show the general condition of the mark and the immediate surrounding area. If additional photographs are required, number these eye-level photos as 2A, 2B...



C. HORIZONTAL VIEW(S) - For survey marks, take at least one additional, daylight photograph oriented near horizontal, and show the mark, with tripod and antenna (if possible), in the foreground, and the mark's identifying surroundings and any significant obstructions or possible sources of multi-path in the background. Show the top of nearby obstructions, if possible. Consider rotating the camera 90 degrees to use the long axis of the image to capture an entire obstruction. **Place a temporary sign in this photograph with the station designation (name) and the direction the camera is pointing, both printed so they are clearly visible in the photograph.** If additional photographs are taken, ideally move around the mark to locations which are 90 degrees apart (preferably cardinal directions). Name these photographs number 3XX, where the "XX" is the cardinal direction the camera is pointing, for example, 3N or 3NE.



3. RECONNAISSANCE PHOTOGRAPHS - Some, none, or all of the digital images described in this section may be required on a given project; refer to the Project Instructions. Each of these photographs requires a sign, a caption, and the correct file name. **The names for all of these files shall begin with "RE" to indicate reconnaissance.**

<u>Required Item</u>	<u>Contents</u>	<u>Description</u>
Sign in Photo	Name & Direction (unless vertical photo)	Place a sign in this photograph with the station designation (name) and the direction the camera is pointing, both printed so they are clearly visible in the photograph.
Digital Caption	Name, PID, LID, Number, Type, Date	See Section 2.2 above
Photo File Name	RE-Name-PID-Number-Date.jpg	See Section 4.4 below

All of the images required by this section shall be designated as reconnaissance (recon) with the letters “RE” at the beginning of their file names. Generally these recon images will not be loaded in the NGS data base but may be required for use during planning, review, etc. All reconnaissance photographs will have digital captions. These captions may be captured on the image or added later. Note, in these specifications, “**RE**” stands for “**RE**connaissance” and “**R**” stands for “**R**ight” runway.

See the Project Instructions to determine which of the following are required:

3.1. PROPOSED LOCATIONS FOR MARKS - Take two photographs of each proposed permanent mark location. These may be one photo number 2 and one number 3, or two number 3 (3A and 3B), depending on which combination better shows the proposed mark location. Include a tripod, stake, sign, or other device showing the proposed mark location.

3.2. RUNWAY END PHOTOGRAPHS - Take at least three photographs at the end of each runway (including thresholds and stopways), as follows:

- Eye-Level (photo type #1) - photo from directly above the mark, showing about 1 meter in diameter,
- Approach (photo type #3) - photo showing tripod over mark in foreground and approach in background
- Across runway (photo type #3) - photo taken from the side of the runway looking across the end of the runway, with a tripod or arrow indicating the end point; include any features used to identify the runway end.

3.3. NAVIGATION AIDS (NAVAIDS) - Take photo(s) (type #3) of all NAVAIDS surveyed. Show the survey tripod in place to indicate the exact point surveyed, or if positioned remotely, add arrows and labels to the photograph indicating the horizontal and/or vertical point(s) surveyed.

3.4. DEPTH OF HOLE PHOTOGRAPHS - Take at least one photograph showing the hole dug or drilled for a concrete or rod mark. Place a measuring device (e.g., tape measure or level rod) in the hole, clearly showing the depth of the hole.

3.5. PHOTGRAMMETRIC CONTROL POINTS (Paneled and photo identified) - **Take two number 3 type photographs** of all photogrammetric control points clearly showing the point. These photos will be used later as an aid in identifying the point on the aerial photographs. Show the mark in the foreground and the nearest identifiable feature in the background. The two photographs should be taken from two different directions, ideally 90 degrees apart (such as from the East and the South). It may be helpful to have the survey tripod in the photograph.

3.6. OTHER REQUIRED PHOTOGRAPHS - as may be required by other instructions.

4. GENERAL:

4.1. IMAGE SIZE - Each image should be about 800 by 1000 pixels when submitted.

4.2. FILE SIZE - Maximum file size for each image is 500 KB, typical file size should be about 50 - 100KB.

4.3. IMAGE FORMAT - Store the digital photographs in JPEG format, approximately 50% reduction.

4.4. PHOTOGRAPH FILE NAME - Use the following file naming convention: “RE” (for reconnaissance photographs only), dash, the station designator, dash, the PID, dash, the photo number (1, 1A, 2, 3N, or 3NE, etc.), dash, date, dot, jpg. For new marks, there is no PID. Use a maximum of 30 alpha-numeric characters to the left of the dot.

Sample File Names

For new stations:	SMITH-3-date.jpg
For existing stations:	JONES-AB1234-1-date.jpg
For recon/photo control photos:	RE-MILLER-3N-date.jpg
For runway end point:	RE-LAX_CL_END_RWY_12R-3-date.jpg

For the runway end point example, “RE” = reconnaissance, dash, LAX = LID, dash, “CL END RWY 12R” = runway end point designator (CL = centerline, END = end, RWY = runway, 12 = runway number, and R = right (or C = center, or L = left), dash, “3” = photo number, and date. Note, “_” (underscores) used to fill blanks. Note, in these specifications, “RE” stands for “reconnaissance” and “R” stands for “right” runway (used if there is a parallel set of runways). Also, the LID may be four characters rather than just three.

The format for the date is: “yyyymmdd”, all numeric.

5. STORAGE MEDIUM - Submit all digital photos together on their own medium (CD), **not on the same medium with other types of data.** For airport work, submit all photos for a given airport in a subdirectory named for that airport.

*Acronyms:

PACS - Primary Airport Control Station

SACS - Secondary Airport Control Station

FBN - Federal Base Network

CORS - Continuously Operating Reference Station (Global Positioning System receiver)

CBN - Cooperative Base Network

ANNEX 1

INFORMATION SHEET FOR TAKING PHOTOGRAPHS OF SURVEY MARKS

EQUIPMENT REQUIRED:

CAMERA (WITH MEMORY CHIP, OR FILM FOR LATER SCANNING)
STIFF BRUSH TO CLEAN OFF MARK AND CLEAN LETTERING
SMALL SHOVEL OR SCRAPER TO CLEAN OFF MARK
YELLOW CONSTRUCTION CRAYON
WHITE BOARD WITH DARK MARKER
WEED WACKER (OR OTHER CUTTING DEVICE) TO CUT BACK GRASS AND WEEDS
COMPASS TO DETERMINE DIRECTIONS

PHOTO #1 - CLOSE-UP:

- SET CAMERA TO HIGH RESOLUTION,
 - SET CAMERA TO MACRO MODE (IF AVAILABLE),
 - DETERMINE MINIMUM FOCUS DISTANCE,
 - SET CAPTION OR DATE INTO CAMERA, IF POSSIBLE,
 - THOROUGHLY CLEAN OFF TOP OF MARK (INCL. LOGO CAP, CONCRETE, ETC.),
 - THOROUGHLY CLEAN LETTERING (DISK OR LOGO CAP),
 - CUT BACK GRASS AND WEEDS, AS REQUIRED,
 - REMOVE SURVEY TRIPOD,
 - OPEN LOGO CAP,
 - RUB YELLOW CRAYON ACROSS STAMPING,
 - ORIENT CAMERA VERTICALLY, AT APPROX. MINIMUM FOCUS DISTANCE,
 - COMPOSE TO INCLUDE ENTIRE DISK, OR TOP OF ROD AND LOGO CAP STAMPING,
 - EXPOSE PHOTOGRAPH IN MID-AM OR MID-PM, IF POSSIBLE, TO OBTAIN GOOD LIGHTING OF THE STAMPING
 - NOTE, IF FLASH IS REQUIRED, MOVE CAMERA SLIGHTLY OFF CENTER TO MINIMIZE REFLECTION.
-

PHOTO #2 - EYE LEVEL

- SET CAMERA TO NORMAL RESOLUTION,
 - SET CAMERA TO NORMAL MODE (NOT MACRO),
 - SET CAPTION OR DATE INTO CAMERA (IF AVAILABLE),
 - IF NOT ALREADY DONE, CLEAN OFF MARK AND STAMPING,
 - CUT BACK GRASS AND WEEDS, AS REQUIRED,
 - REMOVE SURVEY TRIPOD,
 - WRITE STATION NAME ON SIGN AND PLACE NEAR (NOT ON) MARK,
 - CLOSE LOGO CAP,
 - ORIENT CAMERA VERTICALLY AT EYE LEVEL,
 - COMPOSE WITH ENTIRE MONUMENT AND AREA AROUND MARK APPROX. 1 M. IN RADIUS,
 - EXPOSE PHOTOGRAPH.
-

PHOTO #3 - HORIZONTAL VIEW(S)

- SET CAMERA TO NORMAL RESOLUTION,

- SET CAMERA TO NORMAL MODE (NOT MACRO),
- SET CAPTION OR DATE INTO CAMERA (IF AVAILABLE),
- IF NOT ALREADY DONE, CLEAN OFF MARK AND STAMPING,
- CUT BACK GRASS AND WEEDS, AS REQUIRED,
- SET-UP SURVEY TRIPOD OVER MARK,
- WRITE STATION NAME AND CAMERA DIRECTION ON SIGN AND PLACE NEAR MARK,
- CLOSE LOGO CAP,
- ORIENT CAMERA HORIZONTALLY AT EYE LEVEL,
- COMPOSE TO INCLUDE MARK, AND IDENTIFYING SURROUNDINGS, ANY OBSTRUCTIONS OR POSSIBLE SOURCES OF MULTI-PATH,
- EXPOSE PHOTOGRAPH.

Version 8
February 20, 2007

ATTACHMENT S
WRITING STATION DESCRIPTIONS WITH WDDPROC V8

NATIONAL GEODETIC SURVEY
NATIONAL OCEAN SERVICE
NATIONAL OCEANIC & ATMOSPHERIC ADMINISTRATION
U.S. DEPARTMENT OF COMMERCE

TABLE OF CONTENTS

ATTACHMENT S: <u>STATION DESC WITH WDDPROC</u>	PAGE
1. GENERAL.....	3
1.1 DEFINITION OF DESCRIPTION VS. RECOVERY NOTE.....	3
1.2 LEVELS OF COMPLEXITY OF RECOVERY NOTES.....	
	3
1.3 SOFTWARE.....	3
1.4 CHECKING.....	4
1.5 TYPICAL RECOVERY NOTE CASES.....	4
2. DESCRIPTION FORMAT.....	4
2.1 FIRST PARAGRAPH.....	5
2.2 SECOND PARAGRAPH.....	5
2.3 THIRD PARAGRAPH.....	6
3. IMPORTANT POINTS REGARDING DESCRIPTIONS.....	9
3.1 NAMES.....	9
3.2 TERMINOLOGY.....	9
3.3 DISTANCES.....	9
3.4 REPAIR.....	9
3.5 REFERENCE MARK NAMES.....	9
3.6 WCHKDESC.....	9
3.7 METRIC CONVERSION.....	9
3.8 ABBREVIATIONS.....	9
4. THE WDESC PROGRAM.....	9
4.1 GENERAL.....	9
4.2 BACKUP FILE.....	9
4.3 GPS OBSERVATIONS.....	10
4.5 SETTING CONDITION CODES.....	10
4.6 SPACING.....	10
4.7 AGENCY CODES.....	10
5. MARK TYPES.....	10
5.1 CONCRETE MARK.....	10
5.2 ROD MARK GREATER THAN 4 METERS.....	10
5.3 ROD MARKS LESS THAN 4 METERS.....	10
5.4 DISK IN ROCK OUTCROP.....	11

ATTACHMENT S: WRITING STATION DESCRIPTIONS WITH WDDPROC

Descriptions are one of the end products of surveying, along with the positions and the survey marks themselves. All three shall be of highest quality. The descriptions must be complete, accurate and in standardized format if the station is to be reliably and easily recovered for use in the future. Descriptions shall be in the standard NGS format of three paragraphs as described in Section 2 "Description Format."

1. GENERAL

1.1 DEFINITION OF DESCRIPTION VS. RECOVERY NOTE

A. A *description* details the location of a new survey mark, or one not previously in the NGS digital database.

B. A *recovery note* is an update and/or refinement to a description already in the NGS digital database, written upon a return visit to a survey mark.

1.2 LEVELS OF COMPLEXITY OF RECOVERY NOTES

A. No Changes - If an existing station's digital description is complete, accurate, and meets Blue Book requirements, the station may be recovered with a brief recovery note, such as "RECOVERED AS DESCRIBED."

B. Minor Changes - If minor changes or additions to the description are required, they may be added after the above phrase, such as "RECOVERED AS DESCRIBED, EXCEPT A NEW WOODEN FENCE IS NOW 3 METERS NORTH OF THE STATION." See typical cases listed in Section 1.5 A.

C. Major Changes - Where major changes have occurred, major inaccuracies are found, or where required information is missing (in any portion of the description), a complete three-paragraph recovery note, with the same format as a new description, is required. If a measurement discrepancy is found, state that the new distance was verified, for example, by taping in both English units and metric units or by two separate measurements by two different people. See typical cases in Section 1.5 B.

D. Exemption - If a recovery note has been written for the station within one year and no changes have taken place, a new recovery note is not required. Note, this may cause an error message in the description checking software, which may be ignored.

1.3 SOFTWARE - Descriptions and Recovery notes must be properly encoded into a D-file by using NGS WDDPROC software. Please refer to the NGS Web site:

<http://www.ngs.noaa.gov/FGCS/BlueBook/>, Annex P (Geodetic Control Descriptive Data), for information. Note: WDDPROC is used for both new Descriptions and for Recovery Notes.

1.4 CHECKING - Descriptions shall be written by one person and checked by another. Recovery notes should also be checked. For example, a mark setter can draft a description immediately after setting the mark, and an observer can check the description during observations. For existing marks, the reconnaissance person can draft the recovery note and the observer can check it. Descriptions and Recovery Notes should be written while at the station or immediately after visiting a station so that all details are fresh in the writer's mind.

1.5 TYPICAL RECOVERY NOTE CASES

- A. A brief, one or two sentence Recovery Note is adequate:
- i. When the mark is found and the description is completely accurate, sample: ("RECOVERED AS DESCRIBED"),
 - ii. When the mark is found and there are one or two minor changes, ("RECOVERED AS DESCRIBED EXCEPT A NEW WOODEN FENCE IS NOW 3 METERS NORTH OF THE STATION"),
 - iii. When the mark is not found, ("MARK NOT FOUND AFTER 3 PERSON-HOUR SEARCH"),
 - iv. When the mark is not found and presumed destroyed, (" MARK NOT FOUND AND PRESUMED DESTROYED. CONSTRUCTION FOREMAN STATES THAT THE MARK WAS DESTROYED YESTERDAY"),
 - v. When the mark is found destroyed, (" THE MARK IS DESTROYED AND THE DISK HAS BEEN SENT TO NGS" or "THE MARK IS DESTROYED AND ITS PHOTOGRAPH HAS BEEN SENT TO NGS"). Note, for a station to be considered destroyed by NGS, the disk or photograph showing the destroyed mark must be received by NGS.
- B. A complete, new, three-paragraph Description/Recovery Note is required:
- i. When a new mark is set,
 - ii. When an existing mark does not have a PID,
 - iii. When an existing mark does not have an NSRS digital description (i.e., description is not in the NGS database),
 - iv. When an existing mark has only a brief description not meeting the three-paragraph requirement (many bench marks have only short, one-paragraph descriptions),
 - v. When an existing mark's description is no longer accurate or complete.

2. DESCRIPTION FORMAT

The original USC&GS Special Publication No. 247, MANUAL OF GEODETIC TRIANGULATION, page 116, states, "A description must be clear, concise, and complete. It should enable one to go with certainty to the immediate vicinity of the mark, and by the measured distances to reference points and the description of the character of the mark, it should inform the searcher of the exact location of the mark and make its identification certain. It should include only essential details of a permanent character." NGS still follows these guidelines, so that a person with a minimal background in surveying and no local geographic or historical knowledge can easily find the mark by logically following the text of the description.

2.1 FIRST PARAGRAPH - The **first paragraph** is the *description of locality*. This part of the description begins by referring to the airline distance and direction (cardinal or inter-cardinal point of the compass) from the **three** nearest well-known mapped geographic feature(s), usually the nearest cities or towns. Use three references equally spaced around the horizon, if possible. **In writing the Description, always progress from the farthest to the nearest reference point.** Distances in this part of the description shall be in kilometers (followed by miles), or meters (followed by feet), all distances to one decimal place. Detailed measurements which appear elsewhere in the description should not be repeated in this paragraph. Points of the compass should be fully spelled out. Do not use bearings or azimuths. State the name, address, and phone number of public sector property owners (however, phone numbers of private property owners are NOT included). State any advance notice and security access requirements for reaching the station. Also state any unusual transportation methods that may be required to reach the station.

Sample first paragraph:

"STATION IS LOCATED ABOUT 12.9 KM (8.0 MILES) SOUTHWEST OF EASTON, ABOUT 6.4 KM (4.0 MILES) NORTHWEST OF CAMBRIDGE, AND ABOUT 3.6 KM (2.2 MILES) EAST OF SMITHVILLE ON PROPERTY OWNED BY MR. H.P. LAYTON, AND KNOWN AS OLD GOVERNOR JACKSONS ESTATE."

2.2 SECOND PARAGRAPH - The **second paragraph** contains the *directions to reach the station*. This section is one of the most useful parts of a description. It usually enables a stranger to go directly to a station without a delay due to a detailed study of maps or of making local inquiries. It is a route description which should start from a definite point, such as (a) the nearest intersection of named or numbered **main** highways (ideally Interstate and U.S. highways, or at least those which are shown on commonly used road maps), and approximately where that intersection is, or (b) some definite and well-known geographical feature (e.g. main post office or county courthouse) and give its name and general location. Odometer distances shall be given to tenths of kilometers (followed by tenths of miles). For roads with names and numbers, give both in the first occurrence.

- A. The format for the first leg of the "To Reach" is:
- i. FROM THE MAIN POST OFFICE IN DOWNTOWN SMITHVILLE, or FROM THE INTERSECTION OF INTERSTATE XX AND STATE HIGHWAY YY, ABOUT 4.8 KM (3 MILES) NORTH OF SMITHVILLE;
 - ii. GO A DIRECTION (north, northeast, northerly, northeasterly, etc.);
 - iii. ON A ROAD (name or number of road or highway);
 - iv. FOR A DISTANCE (km followed by miles in parentheses);
 - v. TO SOMETHING (intersection, or fork in road, or T-road left or T-road right).

- B. The format for all other legs:
- i. TURN LEFT OR RIGHT, OR TAKE RIGHT OR LEFT FORK, OR CONTINUE STRAIGHT AHEAD;
 - ii. GO A DIRECTION (north, northeast, northerly, northeasterly, etc.),
 - iii. ON ROAD (name of road or highway);
 - iv. FOR A DISTANCE (km followed by miles in parentheses);
 - v. TO SOMETHING (intersection, or fork in road, or side-road left or right, or station on left or right).

All five parts of each leg shall be included in each "To Reach".

Sample:

"TO REACH THE STATION FROM THE INTERSECTION OF INTERSTATE 300 AND MAIN STREET (STATE HIGHWAY 101) IN JONESVILLE, GO EASTERLY ON HIGHWAY 101 FOR 3.7 KM (2.3 MILES) TO AN INTERSECTION. TURN RIGHT AND GO SOUTH ON MILLER ROAD FOR 5.1 KM (3.2 MILES) TO A SIDE-ROAD RIGHT. CONTINUE SOUTH ON MILLER ROAD FOR 6.6 KM (4.1 MILES) TO AN INTERSECTION. TURN LEFT AND GO EASTERLY ON SMITH ROAD FOR 2.4 KM (1.5 MILES) TO STATION ON THE LEFT IN THE FENCE LINE."

Use the word "EAST" if the road goes due east and "EASTERLY" if the road wanders in a general easterly direction. Use intermediate references, such as Miller Road above, if the distance becomes longer than about 5 miles. The place at the end of truck travel should be mentioned. If walking is required, note the approximate time required for packing. If travel to the station is by boat, the place of landing should be stated.

2.3 THIRD PARAGRAPH - The **third paragraph** provides *details of the mark and reference measurements*. It is made up of six parts:

- (A) The station mark type;
- (B) How the mark is stamped;
- (C) How the mark is set;
- (D) Reference measurements;
- (E) The handheld GPS position; and
- (F) PACS or SACS designation, if appropriate.

These sections are not numbered in the description, but shall be in the stated order with the stated information.

SECTION

(A) - State what the mark is:

EXAMPLE

THE MARK IS AN NGS HORIZONTAL DISK, OR A USC&GS TRIANGULATION DISK, OR A STAINLESS STEEL ROD, OR A CHISELED "X", ETC.),

(B) - State how the mark is stamped (in dashes):

STAMPED --JONES 1952--.

(C) - State how and in what the mark is set:

THE MARK IS SET IN A DRILL HOLE IN BEDROCK, OR SET IN A SQUARE CONCRETE MONUMENT, OR IS A ROD DRIVEN TO REFUSAL, ETC. A GREASE-FILLED SLEEVE ONE M LONG WAS INSTALLED.

The description shall specify whether the rod was driven to refusal or whether it met the slow driving rate (this is specified in Attachment V, Section 4.0 as 60 seconds per foot or 90 feet). Also state if a grease-filled sleeve was installed and its length. For a rod mark, the diameter of the stainless steel rod and the diameter of the PVC pipe with the aluminum cap should be in English units, and the length of the plastic sleeve should be given in metric units only.

- State if the mark projects above the ground, is flush, or is recessed and the amount, (for a rod mark state the above for both the rod and the logo cap):

MARK PROJECTS 15 CM (5 IN), OR MARK IS FLUSH WITH THE GROUND, OR MARK IS RECESSED 20 CM (8 IN); OR LOGO CAP IS FLUSH WITH THE GROUND AND TOP OF ROD IS 10 CM (3.9 IN) BELOW THE TOP OF THE LOGO CAP,

- State the depth of the mark, if known:

CONCRETE MONUMENT, 1.2 M (4 FT) DEEP, OR, ROD DRIVEN TO REFUSAL AT 15 M (49 FT)

(D) - State reference distances and directions from three or more permanent objects in the mark's immediate vicinity (farthest to nearest):

IT IS 20.7 M (67.9 FT) SOUTHWEST OF POWER POLE #2345, 15.2 M (49.9 FT) WEST OF THE EDGE OF HIGHWAY 134, AND 3.4 M (11.1 FT) NORTH OF A FENCE LINE.

Examples of objects used as references: existing reference marks, witness posts, center lines of roads, edges of runways, ditches, power or telephone poles, or buildings. Start with the farthest distance. Horizontal distances should be used. If slope distances were measured, that fact should be stated in the paragraph. The distances shall be in meters (followed by English measurement units in parentheses, except as noted in (C) above), and the directions shall be cardinal and inter-cardinal directions, fully spelled out, such as "NORTH", "NORTHEAST", or "NORTH-NORTHEAST". Magnetic bearings from the reference objects are recommended to assist in future recoveries.

(E) Provide a handheld GPS position for all new and recovered marks, and for all proposed mark locations. Include the handheld GPS position in both the scaled position field (in the top portion of the digital description) and in the text, described hereafter. In the text, include the position and the accuracy code of HH1 or HH2, depending on the type of receiver used. HH1 stands for Hand-Held accuracy code 1 (differentially corrected, hand-held GPS), and HH2 stands for Hand-Held accuracy code 2 (stand-alone, hand-held GPS), as follows:

Accuracy code 1 (HH1) = ± 1-3 meters
Accuracy code 2 (HH2) = ± 10 meters

GPS Data Formats:

<u>CODE</u>	<u>LATITUDE</u>	<u>LONGITUDE</u>	<u>SECOND PLACES</u>
HH1	NDDMMSS.ss	WDDMMSS.ss	(2 places of seconds)
HH2	NDDMMSS.s	WDDMMSS.s	(1 place of seconds)

Use "N" or "S" for latitude and "W" or "E" for longitude. Use three digits for the degrees of longitude.

(F) If the station is a Primary or Secondary Airport Control Station mark, the third paragraph shall end with the appropriate designation of Primary or Secondary Airport Control Station): THIS STATION IS DESIGNATED AS A PRIMARY AIRPORT CONTROL STATION.

Sample for a rod mark:

"THE STATION IS THE TOP-CENTER OF A 9/16 INCH STAINLESS STEEL ROD DRIVEN TO REFUSAL DEPTH OF 18M. THE LOGO CAP IS STAMPED --SMITH 2003--. THE LOGO CAP IS MOUNTED ON A 5 IN DIAMETER PVC PIPE. A ONE METER LONG GREASE-FILLED SLEEVE WAS INSTALLED. LOGO CAP IS FLUSH WITH THE GROUND AND TOP OF ROD IS 10 CM (3.9 IN) BELOW THE TOP OF THE LOGO CAP. THE MARK IS 32.4 METERS (101.74 FEET) NORTHEAST OF NORTHEAST CORNER OF THE HOUSE, 16.62 METERS (54.5 FEET) NORTH OF WATER PUMP ALONGSIDE OF HEDGE AROUND OLD FLOWER GARDEN, AND 4 METERS (12.96 FEET) NORTH OF NORTHEAST CORNER OF HIGH HEDGE ENCLOSING OLD FLOWER GARDEN. THE HH1 GPS IS: N304050.2, W1201020.4."

Sample for a concrete monument:

"THE STATION IS AN NGS HORIZONTAL DISK, STAMPED --JONES 2003-- SET IN A ROUND CONCRETE MONUMENT 1.2 M (4 FT) DEEP AND 0.3 M (12 IN) IN DIAMETER. IT IS SET FLUSH WITH THE GROUND. IT IS 32.4 METERS (101.74 FEET) NORTHEAST OF NORTHEAST CORNER OF THE HOUSE, 16.62 METERS (54.5 FEET) NORTH OF WATER PUMP ALONGSIDE OF HEDGE AROUND OLD FLOWER GARDEN, AND 4 METERS (12.96 FEET) NORTH OF NORTHEAST CORNER OF HIGH HEDGE ENCLOSING OLD FLOWER GARDEN. THE HH1 GPS IS: N304050.2, W1201020.4."

3. IMPORTANT POINTS REGARDING DESCRIPTIONS

3.1 NAMES - Use the station designation (name) and PID, exactly as listed in the NGS database, in all survey records. Do not add dates, agency acronyms, or other information to the name, nor the stamping. Note, frequently the stamping and the official station designation are not the same. For example, stampings include the year set, but designations generally do not.

3.2 TERMINOLOGY - Correct NGS survey terminology shall be used in all station descriptions and reports (see GEODETIC GLOSSARY, NGS, 1986).

3.3 DISTANCES - All measurements are assumed to be horizontal unless labeled "slope." Distances measured from a line (e.g., the center-line of a road or a fence line) are assumed to be measured perpendicular to that line. The origin of measurements at the junction of two roads is assumed to be the intersection of center-lines of both roads. Measurements are assumed to be from the center of an object (i.e. power pole) unless stated otherwise.

3.4 REPAIR - Any work done to repair a mark shall be described completely in the updated recovery note. Note: a repair strengthens the mark but must not change its position. For example, adding concrete or epoxy around a disk where some is missing is a repair.

3.5 REFERENCE MARK NAMES - Note, reference marks are abbreviated "RM x" in descriptions, but on "Reference Mark" disks they are stamped "NO. X".

3.6 WCHKDESC - Run the digital D-file through the WCHKDESC program (field-level option), one of several programs within the WDDPROC Software Suite, to identify format and coding errors. This program is accessed by (a) running the WDDPROC program and (b) selecting the option, WCHKDESC, from the main menu.

3.7 METRIC CONVERSION - Use 3.2808333333 feet equals one meter.

3.8 ABBREVIATIONS - Meter = M, kilometer = KM, centimeter = CM, mile = MI, nautical mile = NM, feet = FT, inch = IN.

4. THE WDESC PROGRAM

4.1 GENERAL - The WDESC program, one of several programs within the WDDPROC Software Suite (available over the Web at http://www.ngs.noaa.gov/PC_PROD/DDPROC4.XX/ddproc.index.html), is used to encode descriptions and recovery notes in D-FILE format for the loading of these descriptions into the NGS database. The NGS Blue Book and the WDESC documentation contain information for properly encoding descriptions. Helpful information is contained in the following paragraphs.

4.2 BACKUP FILE - When creating a description file, a backup file is automatically created. Every time a few descriptions are entered, it would be best if they are checked with WCHKDESC and the file corrected. The backup should be renamed **before** reopening the program or it will be overwritten. Always exit from the WDESC program from the pull-down File, option Exit. It is

recommended to save the description file as a new filename every time the program is exited; saving after each description is entered is also recommended.

4.3 GPS OBSERVATIONS - Remember to enter "Y" into the satellite usage code field in the *Header Record* if the mark is suitable for GPS observations.

4.4 SETTING CONDITION CODES - Set the *condition code* on the *Description Header* form as described in **The Description Processing Handbook, Chapter 1, D-FILE Format (for Both Microsoft Windows 95/98/NT and UNIX): The Format of a Description File (D-FILE)**, which is available on the Web by downloading *dformat.htm* from Section 4 of the WDDPROC page (http://www.ngs.noaa.gov/PC_PROD/DDPROC4.XX/ddproc.index.html).

4.5 SPACING - Three separate paragraphs are required in the descriptive text field since they make the description much easier to read. Therefore, when entering the text into the *Description Header* form using the WDESC program, separate each paragraph by pressing the [ENTER] key on the keyboard to add a blank line at the end of the first paragraph.

4.6 FLUSH, PROJECTED, RECESSED - The FPR code is a field on the *Description Header* form in the WDESC program. Set the "FPR" field in the Description Header form to "F", "P", or "R", for Flush, Projected, or Recessed, respectively. In the description, include the logo cap relationship to the ground surface (projecting above, flush with, or recessed below), and include the distance that the top of the rod is below the top of the logo cap. It is important to include information regarding the exact placement of the logo cap for future reference.

4.7 AGENCY CODES - A list of the proper agency codes for the WDDPROC Software Suite can be found on the NGS Web site in WDDPROC ANNEX C (<http://www.ngs.noaa.gov/FGCS/BlueBook/annexc/annexc.index.html>). The agency code to be used for marks that are set by the National Geodetic Survey is NGS. The agency code for marks set by the USC&GS is CGS. Contractors shall use the code assigned to their company. If a contractor does not have a code, a request for one should be emailed to: Burt.Smith@noaa.gov.

5. MARK TYPES

5.1 CONCRETE MARK - For a concrete mark set in accordance with the requirements of Attachment T, use a **setting code** of "07". This classifies the station with a default **vertical stability code** of "C".

5.2 ROD MARK GREATER THAN 4 METERS - For an NGS 3-D stainless steel rod mark driven to a depth of 4 meters or GREATER, use a **monumentation code** of "F" and a *setting code* of "59". This classifies the station with a default **vertical stability code** of "A". Note, if the standard one meter plastic sleeve is used, the vertical stability code must be downgraded to "B".

5.3 ROD MARKS LESS THAN 4 METERS - **ARE GENERALLY NOT ACCEPTABLE**, see "Geodetic Bench Marks", page 27, Table 3.

5.4 DISK IN ROCK OUTCROP - For a disk that is set in solid rock outcrop, use a **monumentation code** of "DH" or "DD" and a **setting code** of "66". This classifies the station with a default **vertical stability** code of "B".

Check the listing of valid **monumentation codes** and **setting codes** in **The Description Processing Handbook, Chapter 1, D-FILE Format (for Both Microsoft Windows 95/98/NT and UNIX): The Format of a Description File (D-FILE)**, which is available on the Web in Annex P of the blue book (<http://www.ngs.noaa.gov/FGCS/BlueBook/>), for the proper codes to use for other types of marks.

Again, refer to the complete directions available at the Web site for using the NGS software package WDDPROC to write the required station descriptions, and be sure to check your final product with WCHKDESC.

Version 2
February 20, 2007

ATTACHMENT T
SETTING CONCRETE MARKS V2

NATIONAL GEODETIC SURVEY
NATIONAL OCEAN SERVICE
NATIONAL OCEANIC & ATMOSPHERIC ADMINISTRATION
U.S. DEPARTMENT OF COMMERCE

TABLE OF CONTENTS

ATTACHMENT T: <u>CONCRETE MARKS</u>	PAGE
1. CONCRETE CHARACTERISTICS.....	3
1.1 GENERAL.....	3
1.2 DESTRUCTIVE FORCES	3
1.3 INGREDIENTS.....	3
1.4 MIXING, PLACING, AND CURING.....	3
1.5 COLD WEATHER PRECAUTIONS	4
2. CONCRETE MONUMENTS.....	4
2.1 STEPS.....	4
ANNEX 1: STANDARD NGS CONCRETE MONUMENT.....	8

ATTACHMENT T: CONCRETE MARKS

(From NGS OPERATIONS HANDBOOK and
MANUAL OF GEODETIC TRIANGULATION, S.P. 247)

1. CONCRETE CHARACTERISTICS

1.1 GENERAL - Concrete should have properties that make it workable, strong and durable. Workability refers to the ease with which concrete can be effectively placed, consolidated, and finished, while remaining free from segregation. Workability depends on the proportions of the ingredients and the shape of the individual particles of aggregate. Strength refers to the ability to withstand external forces without rupturing. For survey monuments, high strength is not the most important property, although strong concrete usually indicates that it is durable. Durability is the ability to withstand deterioration over a long time and is primarily influenced by the watertightness of the cured concrete.

1.2 DESTRUCTIVE FORCES - Several forces can lead to the weakening or deterioration of concrete. The freezing of water in cured cement exerts great pressure against the inner walls of the pores, tending to break down the concrete. In fresh concrete, the expansion of freezing water breaks the bonds developing between solid particles, making the concrete weak and porous. Leaching and chemical attack also have detrimental effects on concrete. Leaching occurs over a long period when water slowly percolates through concrete and dissolves some of its constituents. Chemical attack is particularly common in alkali soils. Dense, impervious concrete is resistant to these destructive forces.

1.3 INGREDIENTS - The quality of the ingredients and their proportions help determine how dense and impervious the cured concrete will be. The ingredients include aggregate, cement, and water. The aggregate should be clean (free from silt and clay, harmful chemicals, and organic matter) and well-graded, i.e., it contains proportionate amounts of many particle sizes. In specifying mix proportions the aggregate is usually divided into two parts -- sand (particle size less than $2/3$ cm) and gravel (particle size greater than $2/3$ cm). Both parts should be well-graded. Aggregates that are porous, split easily, or are otherwise weak or permeable result in poor concrete. Examples of poor aggregates include shale, claystone, sandstone, and micaceous rocks.

Portland cement is designated by one of five types. Type I is for general use where no special properties are needed. Type III is a high-early-strength type for use when concrete will be curing during cold weather. Type V is used where the concrete will be subject to an alkali environment. Types II and IV are not suited for setting marks. Local concrete companies should be contacted to determine the best concrete type to use in the work area.

The water used in a concrete mix should be relatively free of impurities such as acids, alkalis, salts, oil, organic matter, and silt. These can decrease the strength and durability of cured concrete. As a rule, do not use water that you would not drink.

1.4 MIXING, PLACING, AND CURING - Pre-mixed concrete materials may be used. If raw materials are used, the suitable proportions (by bulk volume) of cement to sand to gravel are 1:2:3. If the gravel is made up of fragmented or angular particles, use a little less gravel and

proportionately more sand. Add only enough water to make the mix workable. About half the water added to the mix is used in the chemical reaction (hydration) that causes the paste to harden into binder. If too little water is used, however, the mix will not compact properly and spaces will be left in the mass. **A good indication of the right amount of water is that the mix neither runs nor falls off the shovel but sluggishly slides off and flattens upon hitting the ground.**

1.5 COLD WEATHER PRECAUTIONS - The freezing of fresh concrete has a damaging effect because the expansion of water as it freezes separates the solid particles in the mix. This reduces the strength of the bond and makes the concrete more porous and correspondingly less durable.

Three protective measures should be taken in cold weather, either singly or in combination. First, use warm ingredients. During the first 24 hours after a mix has been placed, it develops little heat of its own to prevent freezing. After 24 hours some heat is developed as a product of the chemical reactions occurring in the mix. The use of warm ingredients is especially beneficial during the first 24 hours. Note, however, that mixing water above 165 degrees F could cause a flash set. To keep the aggregate and cement warm, store them indoors.

Second, use Type III (high-early-strength) cement or special additives that speed curing. Calcium Chloride is good for this in amounts not exceeding 2 pounds per 94-pound sack of cement. The Calcium chloride should be dissolved in the mixing water instead of mixing it with the other ingredients. Other additives include Thoroguard and Trimix. If a large number of concrete marks are being installed by mass production using a "ready-mix" contractor, fast-curing additives should not be added until the concrete is delivered on site.

Third, insulate the finished mark for a week after the concrete is poured. One method is to cover the mark with boards resting on supports. This is covered with paper or plastic, then by a layer of straw, Styrofoam, or similar insulating materials above 15 centimeters thick and finally by a layer of soil 15 to 30 centimeters thick. Pile snow loosely on top if it is available.

2. CONCRETE MONUMENTS (Note: portions of this paragraph apply to concrete collars around rod marks as well as to concrete monuments.)

2.1 STEPS:

1. Obtain property owner permission prior to proposing new mark locations.

2. Install a tall stake (lath) at each proposed site for a new mark. Write the proposed station name on the stake.

3. Obtain clearance from "MISS UTILITY" type services (underground utilities) before digging.

4. Drill or dig a 12 - 14 inch diameter hole in the ground 4.0 to 8+ feet deep. The depth depends on frost penetration in that area. The minimum depth is 4.0 feet. Keep the sides of the hole as smooth as possible. The rounded, bottom portion of the monument

must extend at least one foot below the frost line. See NOAA Manual NOS NGS1, *Geodetic Bench Marks* which contains a diagram showing average frost line depth.

5. Enlarge the bottom portion of the hole using a shovel such as a "sharp-shooter" (also called "drain spade") so that the hole is at least 2 inches larger in radius than the main shaft of the hole. This will make the bottom of the monument bell-shaped; see diagram.

6. Remove or tamp down the loose dirt at the bottom of the hole.

7. Remove any loose dirt that might fall into the hole during concrete installation. A layer of loose dirt from the sides or top of the hole, mixed with the concrete will create a fracture line (or plane) which could lead to the monument breaking, thus destroying the mark.

8. Procure a round, cardboard form 12 inches in diameter to line the top 12 - 18 inches of the hole. Test fit the form in the top of the hole. This form will help avoid any shoulders or mushrooming effect near the top of the monument which might afford purchase for frost heave. The form will also help make a neater looking monument. A cardboard, biodegradable, 12-inch diameter form is commercially available. Allow the form to protrude from the ground 2 - 6 inches.

9. Mix the concrete well before it is placed, otherwise the minute particles of cement will not be sufficiently wet and the aggregate will not be completely covered with paste. Prior to adding water, mix the ingredients well. Then, slowly add water and continue to mix. Do not make the mixture too wet.

10. Dampen the hole before concrete is added so moisture will not be drawn from the fresh concrete into the surrounding soil. In no case should it be so wet as to be muddy

11. Place concrete in the hole. Continuously tamp the mix into a compact mass so it becomes less pervious and consequently more durable. Do not contaminate the interior of the monument with dirt.

12. Place the form into the hole when the level of the concrete is approximately one foot below the surface. Continue to be careful not to allow any dirt to fall into the hole.

13. Add concrete until the top is even with or slightly below the surface of the ground. This helps ensure that the monument is not struck by lawn mowers or snow plows, etc.

14. Smooth off the top of the monument with a trowel. Create a gentle slope towards the outside so that rain water will drain off. Bevel the outside edge of the monument.

15. Stamp the disk prior to installing it in a concrete monument or a drill hole.

Stamp the disk on a stamping block which has a curved surface that matches the curvature of the underside of the disk. Neatly stamp the station designation (name) above the triangle, centered below "HORIZONTAL CONTROL MARK" and then stamp the year below the triangle, centered above "THE DIRECTOR".

16. Set the disk into position in the top center of the monument with the top of the triangle below the name pointing north (so that a visitor facing north will be able to read the disk's lettering). Placing a small amount of concrete on the underside of the disk before setting helps ensure that air is not trapped under the disk.

17. Press the disk into the concrete until the disk edge touches the concrete. Then tap the disk with the handle end of the trowel **until the top edge of the disk is flush with or slightly recessed into the concrete** (to the point that vandals can not get a pry bar under the disk). Do not recess the disk a greater amount because this makes a hollow that will collect rainwater and possibly shorten the life of the mark due to freezing action.

18. Clean the disk. Sprinkle some dry cement on the exposed surface of the disk, then rub it with a clean rag or short bristled brush using circular strokes. This will clean the disk, removing all excess mortar from its surface and recessed letters. Rubbing the wet mortar around the edge of the disk in the same manner is done intentionally to finish its surface and help prevent cracking. Brush away loose cement and make sure that the finished product has a neat appearance.

19. Cover the mark for at least 7 days. This prevents rain from making the mix too wet and from ruining the finished surface. It also prevents the surface from drying too rapidly, leaving too little water for complete hydration. In addition, it prevents debris from sticking to the surface of the wet concrete. A 12 inch diameter lid is available that fits on the 12 inch cylindrical form. This lid will also keep out the dirt during the next step and final clean-up.

20. Replace dirt around the form and tamp into place. At the surface, replace dirt and sod around the form and tamp into place.

21. Rake the area until neat and remove excess materials. Do not leave any construction or other materials at the site. Leave the area as neat as or neater than when you arrived. Note: the protruding form and lid shall be removed later during survey observations.

22. Remove excess dirt and dispose of it properly. In some rural areas there may be a logical spot to dump the extra soil where no one will notice. If the mark is in an area consisting of groomed lawns, the dirt shall be removed from the site.

23. Remove excess concrete from the site. Proper planning should minimize excess concrete. Any excess shall not be dumped on-site.

24. Installation of NGS Witness Posts is at the option of the firm. Generally do not use Witness Posts in areas of high population density nor on airports. They are very useful to future surveyors in more remote areas.

25. Do not add magnetic materials to the monument.

Standard NGS Concrete Monument

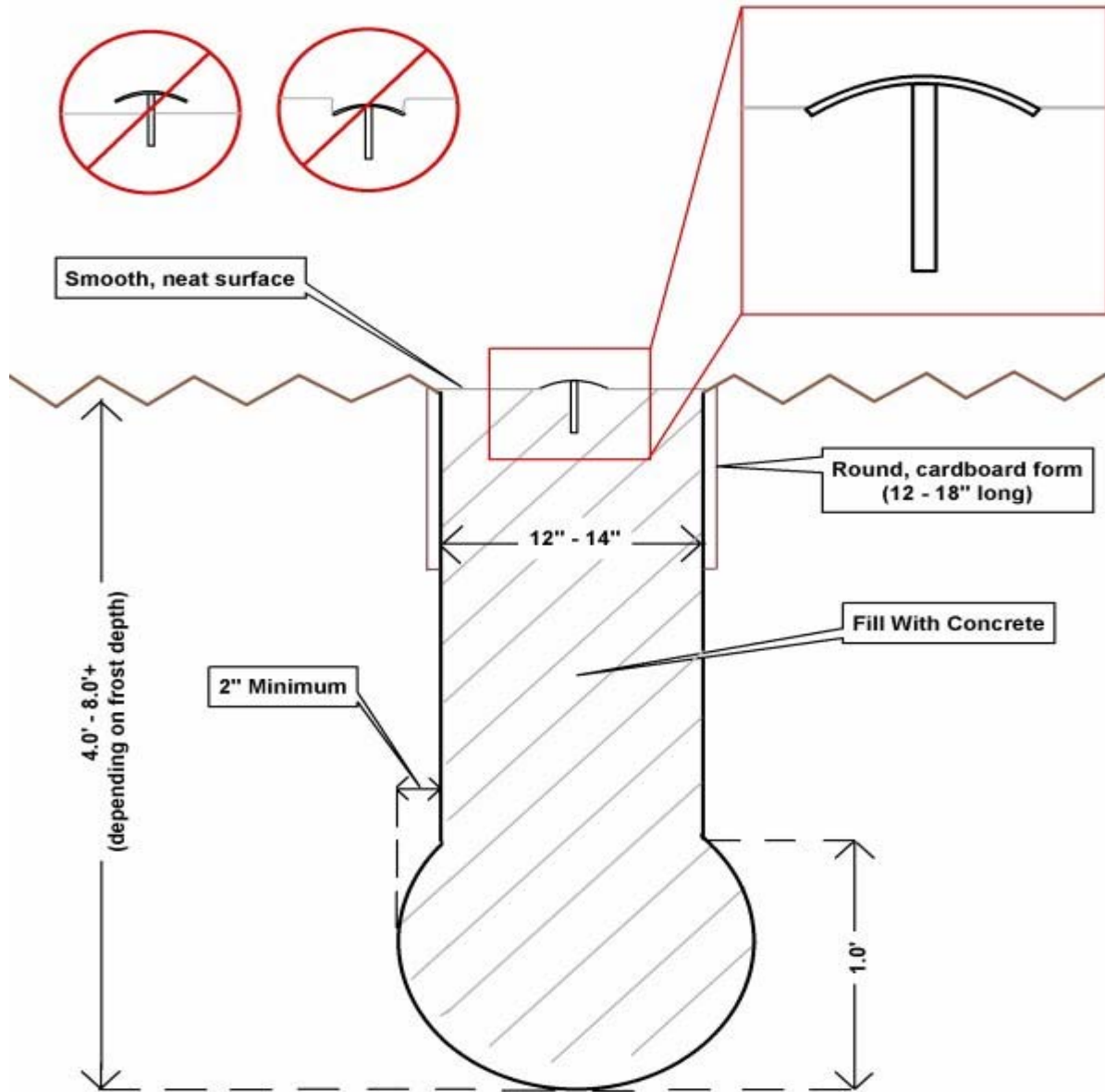

Cross Section Through Round Monument

Version 1
February 20, 2007

ATTACHMENT U
SETTING A SURVEY DISK IN BEDROCK
OR A STRUCTURE

NATIONAL GEODETIC SURVEY
NATIONAL OCEAN SERVICE
NATIONAL OCEANIC & ATMOSPHERIC ADMINISTRATION
U.S. DEPARTMENT OF COMMERCE

TABLE OF CONTENTS

ATTACHMENT U: SETTING A SURVEY DISK IN BEDROCK OR A STRUCTURE

	PAGE
1. GENERAL.....	3
2. SETTING DISKS IN BEDROCK.....	3
2.1 STEPS.....	3
ANNEX 1: DISK IN OUTCROP DIAGRAM.....	5

ATTACHMENT U: SETTING A SURVEY DISK IN BEDROCK OR A STRUCTURE

From NOAA Manual NOS, NGS 1, *Geodetic Bench Marks*

1. GENERAL

Sound bedrock is the most desirable setting for geodetic survey control points. Besides the ease and cost effectiveness with which a disk can be installed in bedrock, it provides the most stable setting that can be used in terms of both underground activity and disturbances inflicted by people. Always use bedrock when a suitable outcrop exists. As a rule of thumb, the bedrock is considered potentially good if the distance between joints and fissures is greater than 1 meter. The National Geodetic Survey geodetic control disks are made of brass or bronze. They are about 9 centimeters in diameter and have a spherical surface to support the foot of a leveling rod and a center point for plumbing survey equipment. Information is imprinted on this surface to identify the monument and to aid the user in obtaining data on it. This logo is recessed so that it does not interfere with the leveling rod or other survey equipment. A deformed shank, about 7.5 centimeters long, is silver-soldered or otherwise attached to the bottom surface of the disk to help prevent the disk from being dislodged.

2. SETTING DISKS IN BEDROCK

2.1 STEPS:

The step-by-step procedure for setting the disk in bedrock utilizing cement is as follows:

- 1.** Stamp the station designation and setting year on the top surface of the disk using 4.75 millimeter (3/16- inch) alpha-numeric steel dies.
- 2.** Pick a fairly level and accessible spot on the outcrop that is intact with the bulk of the rock. A simple test can be performed to help determine the condition and integrity of the rock by placing ones hand in the area that the disk will be set, then striking the outcrop with a moderately heavy hammer and feeling for vibration. Sound outcrop will force the hammer to rebound with each impact and vibration through the rock should be minimal at best.
- 3.** Drill a 2.5 centimeter diameter hole about 10 centimeters into the bedrock and recess the area around the top of the hole to a diameter slightly larger than that of the disk. When the installation is completed, the top of the surface of the disk should sit level and slightly below the surface of the surrounding rock. Chisel a drain channel through the low edge of the drilled recess to allow water to drain from around the finished mark.
Caution: Safety goggles should be worn when drilling into bedrock or masonry.
- 4.** Remove the rock powder from the hole and recessed area, flush and fill the hole with clean water, then pour cement into it. Mixing of the ingredients is done right in the hole.

By adding more water and cement, make enough mortar so that an extra amount is available to place on the underside of the disk. When the mortar is completely mixed, it should be thick but still workable, like heavy mashed potatoes.

5. Clean the disk by wetting then rubbing all surfaces with cement to remove unwanted oils; rinse. Fill the depression on the underside of the disk with mortar using a trowel. Hold the disk loosely upside-down by the end of the shank then gently tap the domed surface of the disk from below with the handle of the trowel several times to allow the mortar to settle and trapped air to escape. This is very important because it will prevent the existence of highly undesirable voids under the disk once it is in place.

6. Place the shank of the disk into the drilled hole and press the mark firmly into place. A slight rotation of the disk back-and-forth and gentle tapping with the end of the trowel handle helps settle the disk completely and evenly into the drilled recess in the bedrock. The disk is considered set when the slight back-and-forth movement stops and the disk sets firmly in place. Work excess mortar around the outer edge of the disk, making sure that it is smooth and slightly overlapping the top outside edges of the disk for security. An exposed edge of the disk would provide an area which could be used by someone or the elements to dislodge it. Fresh mortar on the upper surface of the disk can be easily cleaned off and out of any stamping.

7. Sprinkle some dry cement on the exposed surface of the disk and then rub it with a clean rag or short bristled brush using circular strokes. This will clean the disk very nicely, removing all excess mortar from its surface and recessed letters. Rubbing the wet mortar around the edge of the disk in the same manner is done intentionally to finish its surface and help prevent cracking. Brush away loose cement and make sure that the finished product has a neat appearance.

8. While the mortar is still wet, it must be covered to prevent heavy rains or other foreign debris from ruining its surface and to conceal the disk from people who might tamper with it. A piece of wood, cardboard, heavy paper or similar biodegradable item will suffice.

9. The installation is complete when all accumulated trash has been picked up. Leave the site clean and in good order.

Highway grade epoxy may be used in place of cement if it meets ultraviolet standards and will hold up to all weather conditions. The setting procedures are similar to those described previously except that the drilled hole, though needing to be extremely clean, cannot be wet.

ANNEX 1: DISK IN OUTCROP
DIAGRAM

DISK IN OUTCROP

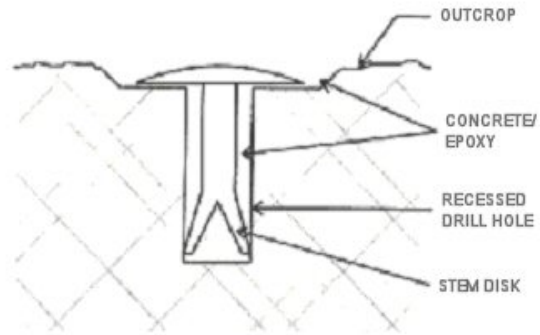

SIDE VIEW

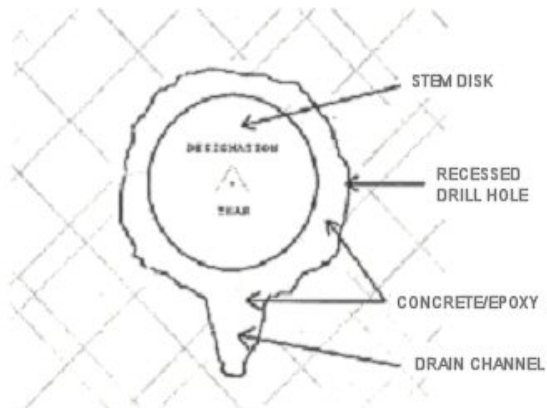

TOP VIEW

Version 1
February 20, 2007

ATTACHMENT V
SETTING AN NGS 3D MONUMENT

NATIONAL GEODETIC SURVEY
NATIONAL OCEAN SERVICE
NATIONAL OCEANIC & ATMOSPHERIC ADMINISTRATION
U.S. DEPARTMENT OF COMMERCE

TABLE OF CONTENTS

ATTACHMENT V: <u>SETTING AN NGS 3-D MONUMENT</u>	PAGE
1. DISCLAIMER.....	3
2. INTRODUCTION.....	3
3. REFERENCES.....	3
4. REQUIREMENTS.....	4
4.1 RECOMMENDED EQUIPMENT FOR SETTING MONUMENTS.....	4
4.2 MATERIALS REQUIRED FOR EACH MARK.....	5
4.3 SETTING PROCEDURES.....	5
ANNEX 1: DIAGRAM OF AN NGS 3-D ROD MARK.....	9

ATTACHMENT V: SETTING AN NGS 3-D MONUMENT

Based on "Revised NGS 3-Dimensional (3-D) Rod Mark" [Draft Version] by:
Curtis L. Smith
National Geodetic Survey
July, 1996

1. DISCLAIMER

This document is intended only for the purpose of providing the user with guidelines for planning and implementation of this style of survey monument. The distribution of this document or the mention of a commercial company or product contained herein does not constitute, in any way, an endorsement by the National Geodetic Survey (NGS).

2. INTRODUCTION

The extensive use and accuracies achieved by the Global Positioning System (GPS) for geodetic surveying applications have highlighted the need for increased stability in survey control point monumentation. Repeatability of accurate positions obtained through GPS require that geodetic monuments reflect this accuracy with properties of permanence and stability both horizontally and vertically.

Factors affecting the stability of survey monuments include frost heave action, changes in ground water levels and local settlement. Consult soil and geotechnical specialists about local ground conditions. Manuals, such as NOAA Manual NOS NGS 1, "Geodetic Bench Marks", document soil types and frost penetration zones nationwide.

The recommended survey marker that produces stability for most conditions is the three-dimensional (3-D) drivable survey monument. The principal component of this monument is a 9/16-inch stainless steel rod driven into the ground, utilizing a gasoline powered reciprocating hammer, until refusal or a reduced driving rate has been achieved. The rounded top of the rod is the survey datum point. The upper 1 meter of the rod is encased in a 1-inch greased filled plastic extruded fin sleeve that is held horizontally stable by back-filled, washed sand. Effects of up and down ground movement during freeze/thaw or wet/dry conditions are removed from the anchored rod by the grease filled sleeve promoting vertical stability. A 5 or 6-inch PVC pipe with attached standard aluminum logo cap protects and identifies the top of the monument. (See documentation in this manual for specific mark setting procedures).

3. REFERENCES

NOAA Manual NOS NGS 1. Geodetic Bench Marks, by Floyd, Richard P., September 1978. Geometric Geodetic Accuracy Standards and Specifications for Using GPS Relative Positioning Techniques, by Federal Geodetic Control Committee, August 1989.

4. REQUIREMENTS

4.1 RECOMMENDED EQUIPMENT FOR SETTING MONUMENTS

A. Rod Drivers and Accessories:

- 1- Any driver with a minimum impact force of 25 foot pounds per blow, such as Wacker Model BHB 25 (with tool kit) or Pionjar Model 120 (with tool kit), for driving stainless steel rods.
- 1- Rod Driving Insert, holds machine on rod and acts as impact point while driving rods.
- 1- Shovel Bit, for machine to help start and dig holes, not required but may be helpful.
- 1- Pint, Required Oil Type and Calibrated Container, for determining gas/oil mix.
- 1- Gas Containers and Gasoline, for driving machine and generator.

B. Digging the Hole:

- 1- Post Hole Digger, capable of digging a hole 4-feet deep.
- 1- Gas Powered post Hole Digger with Augurs, not required but increases productivity.
- 1- Digging Bar, for rocks and hard to dig holes.

C. Driving the Rod:

- 1- 2 lb. Hammer, to start rods, stamp designations, etc.
- 2- 8" Quality Pipe Wrenches (i.e. Rigid), for attaching lengths of stainless steel rods.
- 1- Bottle, Loctite, for cementing threads into the stainless steel rods.

D. Finishing the Rod:

- 1- Hack Saw with extra Quality Blades, for cutting stainless steel rod.
- 1- 4" or 5" Grinder (electric or battery powered), for finishing top of rod.
- 1- Gas Powered Electric Generator, to power grinder and/or drill.
- 2- Sanding Disks (medium grade), for grinder.
- 1- Steel File(s), for fine finishing top of rod.
- 1- Centering Sleeve, to help center punch mark on top of rod.
- 1- Center Punch, to punch plumbing point on top center of rod.
- Assorted Sand Paper or Sanding Pad, for fine finish to top of rod.

E. Finishing the Monument:

- 1- 1/4-inch Stamping Set, for lettering and numbering station designation/date.
- 1- Hand Saw, for cutting 5 or 6-inch PVC pipe.
- 1-Bucket or Wheel Barrel, to mix cement/move unwanted dirt.
- 2- 5 Gallon Water containers and Water, to mix cement and clean equipment.
- 1- Hoe, to mix cement, can be replaced by "Sharp Shooter Shovel".
- 1- Heavy Rubber Mallet, to help lower logo cap/5-inch PVC into cement.
- 1- Cement Finishing Trowel, to smooth top of concrete for neat appearance.
- 1- Stiff Vegetable Type Brush, to clean logo cap and hinges.

F. Assorted Accessories:

- 1- Tool Box with regular assortment of tools, for incidental repairs: slotted and Phillips Head Screw-Drivers, Pliers, Needle Nose Pliers, Wire Cutters, Assorted Wrenches,

Sockets, Allen Wrenches, Wire Brush.

1- Round Nose Shovel, to help dig hole and move unwanted dirt.

1- Tile Spade (“Sharp Shooter Shovel”), to help dig hole and mix cement.

1- Roll Black Tar Paper (Felt Paper), for making a round form for top of monument.

1- 30 Meter Tape Measure, for distances in station description.

Leather or Cotton Gloves, Assorted Rags or Paper Towels.

4.2 MATERIALS REQUIRED FOR EACH MARK

Lengths of 9/16-inch Stainless Steel Rods, 4-foot sections.

1- 4 to 5-inch piece of Stainless Steel Rod, used as impact point and protection while driving rods.

Adequate supply of 3/8-inch Threaded Stainless Steel Studs.

1- Steel Spiral (fluted) Rod Entry Point, standard order.

1- Aluminum Logo Cap, standard order.

1- Schedule 40 PVC Pipe, 5 or 6-inch diameter, 24-inch length.

1- Plastic Extruded Fin sleeve, 1-inch diameter, 3-feet minimum length.

2- Plastic end Cap Alignment Bushings, center drilled to 9/16-inch (for extruded fin sleeve).

1- Pint, PVC cement, can be replaced with adequate Epoxy type.

1- Pint, PVC Cleaning Solvent, when using PVC cement.

1- 17 ounce tube, Non-Toxic, Food Grade Grease, with Applicator (i.e. grease gun).

Ready Mix Concrete (Amount depends on width and depth of hole).

2- Pounds, Portland Cement, added to enhance integrity of ready mix concrete if necessary.

0.5- Cubic feet, Washed Sand, fills bottom of hole and inside of PVC pipe around grease sleeve.

4.3 SETTING PROCEDURES

1. Ensure the monument site selection has been discussed with airport management and/or property owners, and the location meets all station siting requirements. Inquire about future construction which may affect mark longevity.

2. Contact "MISS UTILITY" type services to inquire about underground utilities before digging or driving a rod.

3. The time required to set an average mark using the following procedures and referencing the diagram on the following page is 2 to 3 hours. Several steps, such as steps 4, 5, and 7, can and should be accomplished at a maintenance shop.

4. Stamp station designation and year of establishment into the blank area on the collar of the logo cap.
5. Cut a 20-inch section of 5 or 6-inch PVC pipe. Ensure the end that will receive the logo cap is cut true and is clean. Using primer and solvent cement formulated specifically for PVC, glue the stamped aluminum logo cap to the end of the 20-inch PVC section. If this step is performed on site, allow time for the glue to set by digging the hole and driving the rod after preparing the PVC and logo cap.
6. Using a power auger or post hole digger, drill or dig a round hole in the ground 12 to 14-inches in diameter, and 22 inches deep. Extend the center of the bottom of the hole by drilling or digging a 3 to 6-inch diameter hole an additional 21 inches for a total depth of 43 inches. This extended area will be back-filled with washed sand around grease sleeve.
7. Glue both plastic end cap alignment bushings on a 3-foot section of the plastic extruded fin sleeve. Let glued ends dry completely. Pump food grade grease into capped sleeve until 3/4 full allowing for displacement by rod and completing the grease filled sleeve.
8. Using a standard 3/8-inch threaded stud coated with Loctite (Use Loctite on all *permanent* connections). Attach two 4-foot sections of stainless steel rods together. At one end of the length of rod, attach a standard spiral (fluted) rod entry point with a 3/8-inch threaded stud. On the opposite end, attach a short 4 to 5-inch piece of rod with a 3/8-inch threaded stud. Tighten all connections using two pipe wrenches a good 1/4 to 3/4 turn past the point of contact of all rod ends except the impact point which will be continually removed. This tightening requires a certain "feel" and ensures that the rod ends are seated together with greatest possible tension yet not to the point of breaking a stud. Rods tightened in this fashion should not vibrate loose when they are driven into the ground.
9. The 8-foot long connected rod is centered into the bottom of the hole and driven with a 2-pound hammer until rod is secure and as plumb as possible. A 2x4 with a 1/2" hole can be centered and braced over the hole to help guide the rod straight into the ground. Drive the section of rod to about the top of the hole with a gas powered reciprocating driver such as Whacker model BHB 25, Pionjar model 120, or another machine with an equivalent driving force.
10. Remove the short piece of rod (impact point) leaving the threaded stud section of the rod in the ground. Attach another 4-foot section of rod and, using a new threaded stud, thread on the impact point. This "cycling" of a new stud from impact point into the top of the rods in the ground insures unweakened studs at all connections. Remember to coat threads on the permanent connections with Loctite. Tighten securely utilizing pipe wrenches as described above in step 9. Always tighten rods maintaining a clockwise pressure to avoid loosening rods already in the ground. Drive the new length of rod into the ground with the reciprocating driver.
11. Repeat step 10 until the rod refuses to drive further (anchored), or until a driving rate of 60 seconds per foot is achieved. In the event that the rod will not sufficiently slow down to meet desired driving rate, terminate upon reaching 90 feet (22.5 rods). This will leave about 2 feet of

rod out of the hole. If possible, let the rod set overnight, then drive the remaining 2 feet of rod to determine whether driving rate has reduced. If rod feels secure in ground, use this depth even though minimum driving rate of 60 seconds per foot has not been met. If the rod turns freely in clockwise direction, contact NGS for a decision to drive additional rods. Sometimes, all that is necessary to achieve a well anchored rod is driving it a few more feet. In other instances an additional hundred feet may be required. Indicate in the written station description the depth of rod, and whether it was driven to refusal or met the slow driving rate. Also include a description of any unusual mark setting circumstances.

12. When refusal or prescribed driving rate is reached, cut off the rod with a hacksaw or comparable tool, always removing at least the tapped and threaded portion, leaving the top of rod about 3 inches below ground surface. Shape the top of the rod to a smooth, hemispherical surface using a portable grinding machine using a grinding attachment or sanding wheels, files, and sand paper to produce a nicely finished, rounded surface. Ragged edges or grinding marks are not acceptable on top of the finished rod.

13. The datum point must then be created by center punching a dimple on top of the rod to provide a plumbing (centering) point. Place the centering sleeve over the top of the rounded rod to facilitate locating the exact center of the rod. Punch a substantial dimple 1/16-inch deep, into the top of the rod using a punch and hammer or spring loaded center punch. Several blows may be needed to create a sufficient dimple. Remember, this is the actual survey point, so don't hesitate to spend a few extra minutes to produce a professional, finished product.

14. Insert the grease filled sleeve, produced in step 7, over the rod with the unfilled portion at the top. Upper end of the sleeve will fill as rod displaces grease from the bottom. The datum point on top of the rod should protrude through top of the sleeve about 3-inches with sleeve extending to the bottom of the hole. Clean the residual grease off the exposed top of the rod.

15. Back-fill and pack with washed sand the bottom 23 or more inches of the hole around the outside of grease sleeve. This fills the bottom of the hole and helps stabilize the sleeve.

16. Place the 5 or 6-inch PVC pipe and logo cap over and around the grease sleeve and rod in the center of the hole. The bottom of the PVC pipe should extend into the top of the sand in the bottom of the hole. Leave the top of the logo cap and PVC pipe slightly higher than the top of the ground surface until the concrete is in place. Back-fill the center of the PVC pipe with washed sand around and to within 1-inch from the top of the grease filled sleeve. The rod should be centered in the PVC pipe.

17. Mix concrete in a bucket or wheel barrel to pasty, well moistened consistency like mashed potatoes. Add Portland cement, if necessary, in sufficient quantity (1 to 2 pounds) to enhance concrete mix or dry an over moistened mixture to maintain adequate consistency. A good indication of adequate consistency is that the mix neither runs nor falls off the shovel but sluggishly slides off and flattens upon hitting the ground. Pour concrete into the hole around the logo cap and PVC pipe casing filling to slightly below the ground surface. To avoid frost heaving of the PVC collar, a round form should be used to ensure the outside walls of the concrete are vertical, and do not produce a mushroom shaped wedge at the top of the mark. Open

the logo cap and grasp the PVC pipe then shake to settle concrete around the pipe to fill voids. Add concrete to within 1/2-inch of the ground surface.

18. Trowel smooth the top of concrete to a fairly finished surface. Tap alternate edges of the logo cap, using a rubber mallet or hammer and wooden block, lowering it and the attached PVC pipe into the surface of the concrete. Finish the top of the concrete by troweling a smooth, finished surface, round in appearance, and sloped slightly outward to aid drainage of rain water.

19. Add sand to the inside of the PVC pipe to bring its level to within 1-inch of the top of the grease sleeve. Clean any overlapping concrete from the surface of the logo cap using the vegetable brush. The finished height of logo cap and access cover should be slightly lower than the surface of the ground. The logo cap should be approximately in the center of the top of the concrete. Datum point should be about 3-inches below the cover of the logo cap and centered in the 5 or 6-inch PVC pipe. The top of the grease filled sleeve should be about 3-inches below the datum point and the washed sand 1-inch below the top of the sleeve. Clean any cement that may have gotten onto the exposed rod or datum point.

20. Clean all equipment and remove all debris such as extra cement, excess dirt, and trash, leaving the area in the condition it was found.

ANNEX 1: DIAGRAM OF AN NGS 3-D ROD MARK

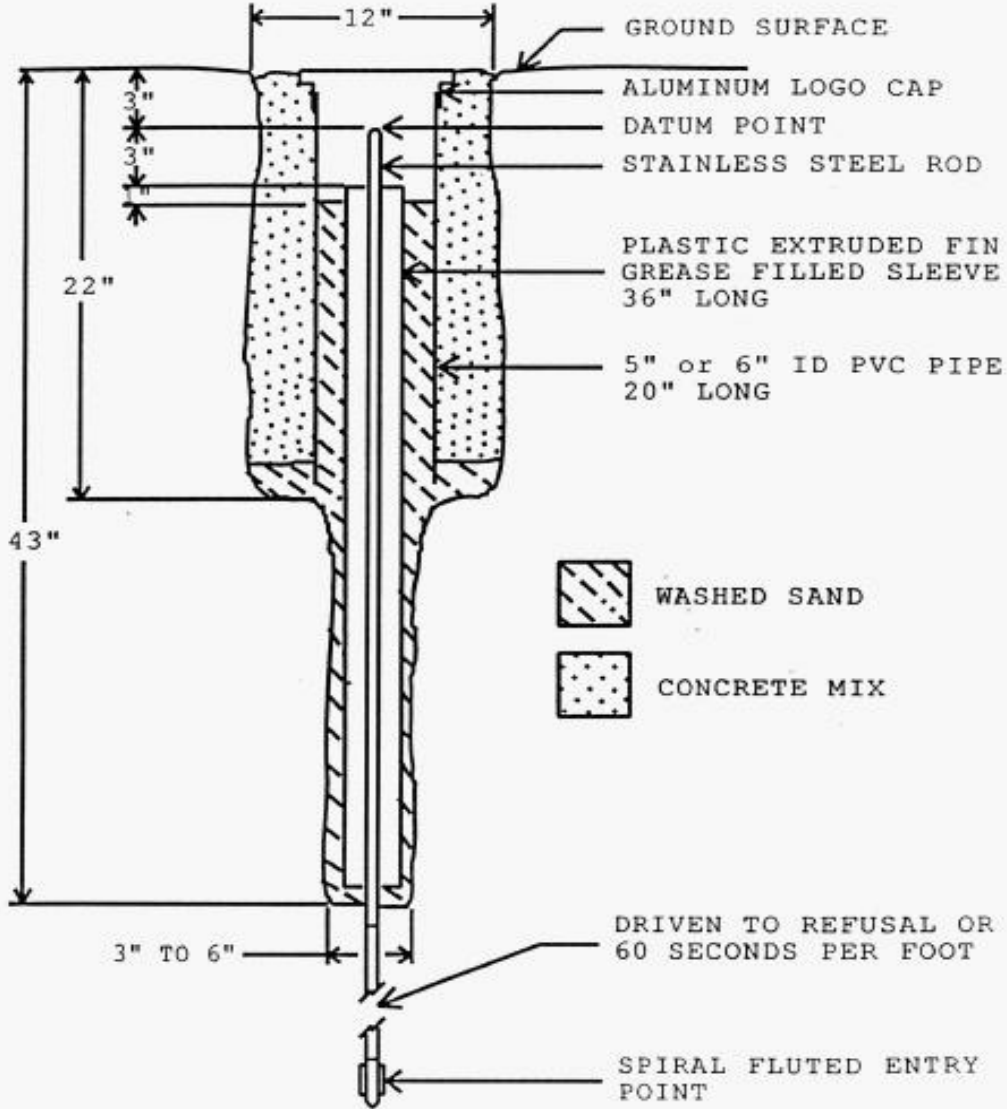

Schematic of the Revised NGS 3-D Rod Mark, Side View

Version 3
February 24, 2006

ATTACHMENT W
COMMONLY USED ACRONYMS

NATIONAL GEODETIC SURVEY
NATIONAL OCEAN SERVICE
NATIONAL OCEANIC & ATMOSPHERIC ADMINISTRATION
U.S. DEPARTMENT OF COMMERCE

ATTACHMENT W

Commonly Used Acronyms

CBN – Cooperative Base Network
CGS – U.S. Coast & Geodetic Survey (See also USC&GS)
CO -- Contracting Officer
CORS – Continuously Operating Reference Station
COR -- Contracting Officer's Representative
DE -- Difference in Elevation
FBN – Federal Base Network
FGCC -- Federal Geodetic Control Committee
FGCS -- Federal Geodetic Control Subcommittee
GIS -- Geographic Information System
GPS -- Global Positioning System
GRS80 -- Geodetic Reference System 1980
HARN -- High Accuracy Reference Network
LIDAR -- Light Detection And Ranging
NAD 83 -- North American Datum of 1983
NAVD 88 – North American Vertical Datum of 1988
NGS -- National Geodetic Survey
NOAA -- National Oceanic and Atmospheric Administration
NOS -- National Ocean Service
NSRS – National Spatial Reference System
PACS -- Primary Airport Control Station
PID -- Permanent Identifier
POC -- Point of Contact
PRVD 02 -- Puerto Rico Vertical Datum of 2002
SACS -- Secondary Airport Control Station
SOW -- Statement of Work
SSN – Station Serial Number
USACE -- U.S. Army Corps of Engineers
USC&GS – U.S. Coast and Geodetic Survey
USGS – U.S. Geological Survey

Version 1
February 20, 2007

**ATTACHMENT X
BENCH MARK TIES**

NATIONAL GEODETIC SURVEY
NATIONAL OCEAN SERVICE
NATIONAL OCEANIC & ATMOSPHERIC ADMINISTRATION
U.S. DEPARTMENT OF COMMERCE

TABLE OF CONTENTS

ATTACHMENT X: <u>BENCH MARK TIES</u>	PAGE
1. INTRODUCTION.....	3
2. SINGLE MARK LEVEL TIE (3 RD ORDER).....	3
3. OBSERVING SEQUENCE FOR CONVENTIONAL LEVEL.....	3
4. OBSERVING SEQUENCE FOR DIGITAL LEVEL.....	5
5. DATA SUBMISSION.....	6
ANNEX 1: OBSERVATIONS FOR BENCH MARK TIES BLANK FORM.....	7

ATTACHMENT X: BENCH MARK TIES

1. INTRODUCTION

The purpose of these guidelines is to provide the information necessary to transfer an elevation from an existing NAVD88 benchmark that cannot be used for GPS observations to a nearby GPS station. The two stations must be “closeby” which is defined here as no more than four “set-ups” of the level instrument.

2. SINGLE MARK LEVEL TIE (3RD ORDER)

An assumed elevation for the bench mark can be used in the leveling since the principal concern is with the **difference of elevation** between the bench mark and the GPS station. It should be noted that the published elevation of the GPS station would only be published to the nearest centimeter. This is because the absolute elevation of the bench mark cannot be verified without incorporating other bench marks into the survey as a check. Many projects do not provide the resources required for this multiple mark check, but it is still imperative that the GPS station have the best precision allowable.

Record rod readings to millimeters or hundredths of feet. The model and type of instrument and rods (e.g., fiberglass, aluminum, single piece, etc.) as well as rod scale units (e.g., meters, feet, or bar code) should be entered on the “Observations of Bench Mark Ties” form where indicated. See Annex 1.

3. OBSERVING SEQUENCE FOR CONVENTIONAL LEVEL

1. Remove equipment from travel cases, attach level instrument to tripod, and let equipment acclimate to local conditions. Perform instrument check per the manufacturer’s instructions. Set up the instrument about halfway between the stations, but no more than 70 m (230 ft) away from either point or from one of the points and a turning pin in the case of multiple setup requirements. Backsight distance to foresight distance imbalance shall be less than 5 meters. Accumulated backsight to foresight distance imbalance shall be less than 10 meters in the case of multiple setups.

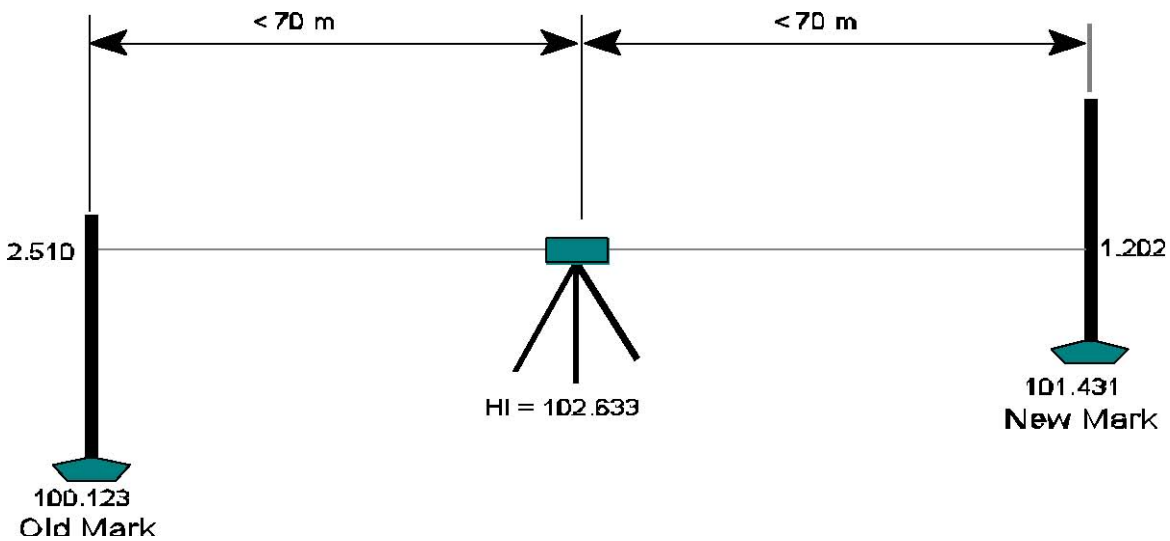

Figure 1. Direct old mark to new mark level tie. **Note:** Backsight-foresight distance imbalance should be less than 5 meters.

2. Plumb the level rod on the highest point of the old mark. Let's call the old mark M 123. Record the designation of the point and its published elevation noting the reference vertical datum and units of measure.

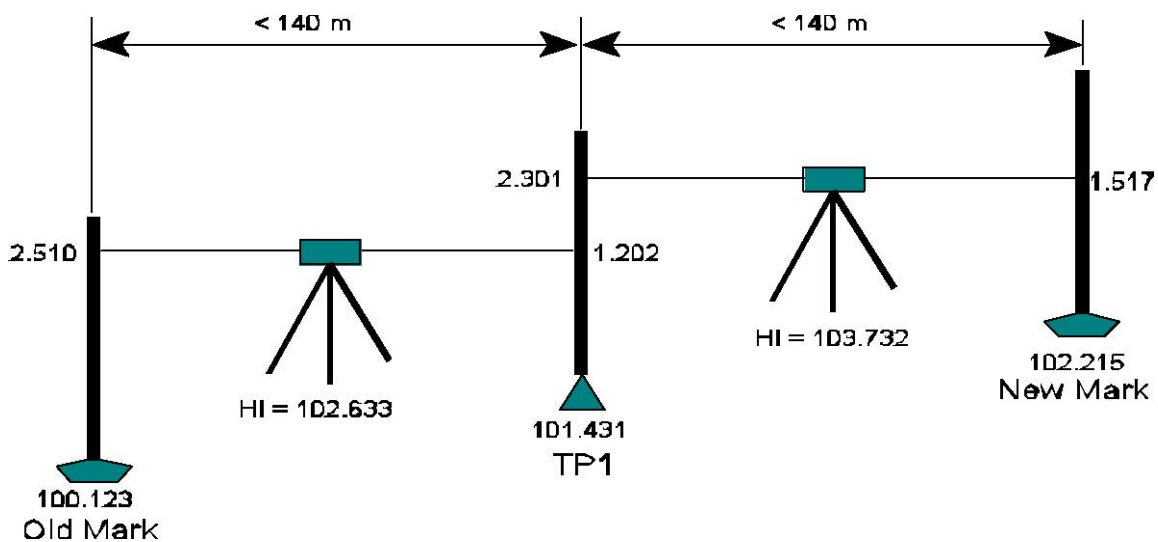

Figure 2. Old mark to new mark level tie for distances over 140 m. **Note:** Accumulated backsight-foresight setup imbalance should be less than 10 m.

3. Backsight Reading: Observe the intercept of the middle reticule of the rod scale as backsight reading. Record the rod reading to the nearest millimeter (or hundredths of a foot) as indicated above. Record the stadia reading to determine distance from the point to the instrument.

4. Compute height of instrument, HI, which is the sum of the backsight and the published elevation.

5. Plumb the rod on the highest point of the new bench mark. Record the designation of the new mark, e.g., M 123 RESET, or TP1 (for turning point 1 in the case of multiple setups).

6. Foresight Reading: Observe the intercept of the middle reticule of the rod scale as foresight reading. Record the stadia reading to determine distance from the point to the instrument.

7. Compute the elevation of the new point, new bench mark, or turning point, which is the difference of the HI minus the foresight.

8. Reset and re-level the instrument. Level backward from the new point to the old, in the same manner as steps 2 through 7.

Note: The elevation computed for the old point as a result of the backward leveling may differ by no more than $\pm 12D$ (where D is the shortest length of section in kilometers one-way) from the published elevation.

9. To compute the elevation difference from the old mark to the new, subtract the mean of the two elevations for the old mark from the elevation for the new mark.

4. OBSERVING SEQUENCE FOR DIGITAL LEVEL

These observing procedures are intended for use with digital levels.

1. Remove equipment from travel cases, attach level instrument to tripod, and let equipment acclimate to local conditions. Perform instrument check and adjustment as outlined in the digital level manual.

2. Set up the instrument about halfway between the stations. Limit sight lengths to no more than 70 m (230 ft) from either point or from one of the points and a turning pin in the case of multiple setup requirements, e.g., distance between points is greater than 140 meters. Backsight distance to foresight distance imbalance shall be less than 5 meters. Accumulated backsight to foresight distance imbalance shall be less than 10 meters in the case of multiple setups.

3. Level up the instrument using the three foot screws while observing the bulls-eye bubble. Turn on the instrument and select the backsight/foresight level program. Confirm that you want to start then enter the starting elevation for the old mark. Set and confirm instrument parameters, e.g., meaning 3 measurements, display maximum decimal places, record readings to onboard module, and observing configuration, such as rod type, and metric units.

4. Plumb the level rod on the highest point of the old mark, e.g., domed top of disk M 123. Record the designation of the point and its published elevation, noting the reference vertical datum and units of measure.

5. Backsight Reading: Point using the vertical crosshair of the level instrument on the middle of the rod over the old mark and use the focusing knob to bring the image of the rod into sharp focus. Depress the measure button and record the rod reading. Note distance from rod to instrument. It should be less than 70 meters.

6. Plumb the rod on the highest point of the new bench mark. Record the designation of the new mark, e.g., M 123 RESET, or TP1 (for turning point 1 in the case of multiple setups).

7. Foresight Reading: Point and focus the level instrument on the rod over the new mark. Depress the measure button and record the rod reading. Note distance from rod to instrument. It should be less than 70 meters. Note imbalance between backsight and foresight distances. This difference shall be less than 5 meters.

8. The elevation of the new bench mark or turning point is computed as the sum of the backsight reading and the published elevation minus the foresight reading.

9. Reset and re-level the instrument. Level backward from the new point to the old, in the same manner as steps 2 through 7. Use the elevation determined from the forward leveling as the starting elevation for the backward leveling. The elevation computed for the old point as a result of the backward leveling may differ by no more than $\pm 12D$ (where D is the shortest length of section in kilometers one-way) from the published elevation.

10. To compute the elevation difference from the old mark to the new, subtract the mean of the two elevations for the old mark from the elevation for the new mark. The elevation for the new bench mark will be this computed difference, mean of both forward and backward leveling, plus the published elevation of the old bench mark.

5. DATA SUBMISSION

The following **shall be supplied** by the submitting office:

1. Completed “Observations for Bench Mark Ties” form. See Annex 1.
2. Digital Levels: Paper as well as digital copy of leveling observations.

ATTACHMENT Y
ATTACHMENT Y - SETTING A MARK IN OR NEAR BEDROCK

TO
SCOPE OF WORK FOR GROUND SURVEYS

NATIONAL GEODETIC SURVEY
NATIONAL OCEAN SERVICE
NATIONAL OCEANIC & ATMOSPHERIC ADMINISTRATION
U.S. DEPARTMENT OF COMMERCE

ATTACHMENT Y - SETTING A MARK IN OR NEAR BEDROCK

CASE I – BEDROCK AT GROUND SURFACE

Set a disk in a drill hole per Attachment entitled, “**SETTING A DISK IN BEDROCK OR A STRUCTURE**”

CASE II – BEDROCK LESS THAN ~1.5 FOOT (0.5 METER) BELOW SURFACE

Same as CASE I, then, install a protective monument box, such as an iron utility well cover, plastic valve box, or PVC pipe with aluminum logo cap, surrounding and over the disk for protection and access. Surround the box or pipe with a concrete collar to hold it in place. Also consider a CASE III mark.

CASE III – BEDROCK ~1.5 - 3 FEET (0.5 - 1 METER) BELOW SURFACE

Dig out an area at least 0.5 meter in diameter and clean off the top of the bedrock removing all loose material and washing down the rock to provide a clean surface. If the bedrock is smooth, drill holes or chisel furrows to afford better anchorage for the concrete monument. Set a concrete monument on top of the bedrock with a disk on the surface.

CASE IV – BEDROCK ~ 3 – 13 FEET (1 – 4 METERS) BELOW SURFACE

Do not set a rod mark that is less than 4 meters long. If bedrock is reached less than 4 meters below the surface then either set a concrete mark (according to the Attachment entitled, “**SETTING CONCRETE MARKS**”), or move to a different location to set a rod mark (according to the Attachment “**SETTING A NGS 3-D MONUMENT**”).

CASE V – BEDROCK DEEPER THAN 4 METERS

Set a rod mark or concrete monument per appropriate Attachments.

See graphic on next page.

setting a mark in bedrock

case 1:	case 2:	case 3:	case 4:	case 5:
bedrock at surface	bedrock 0 - ½ m deep	bedrock ½ - 1 m deep	bedrock 1 - 4 m deep	bedrock > 4 m deep
mark in bedrock	mark in bedrock in a protective well	concrete monument affixed to bedrock	concrete monument in soil okay	rod mark okay.

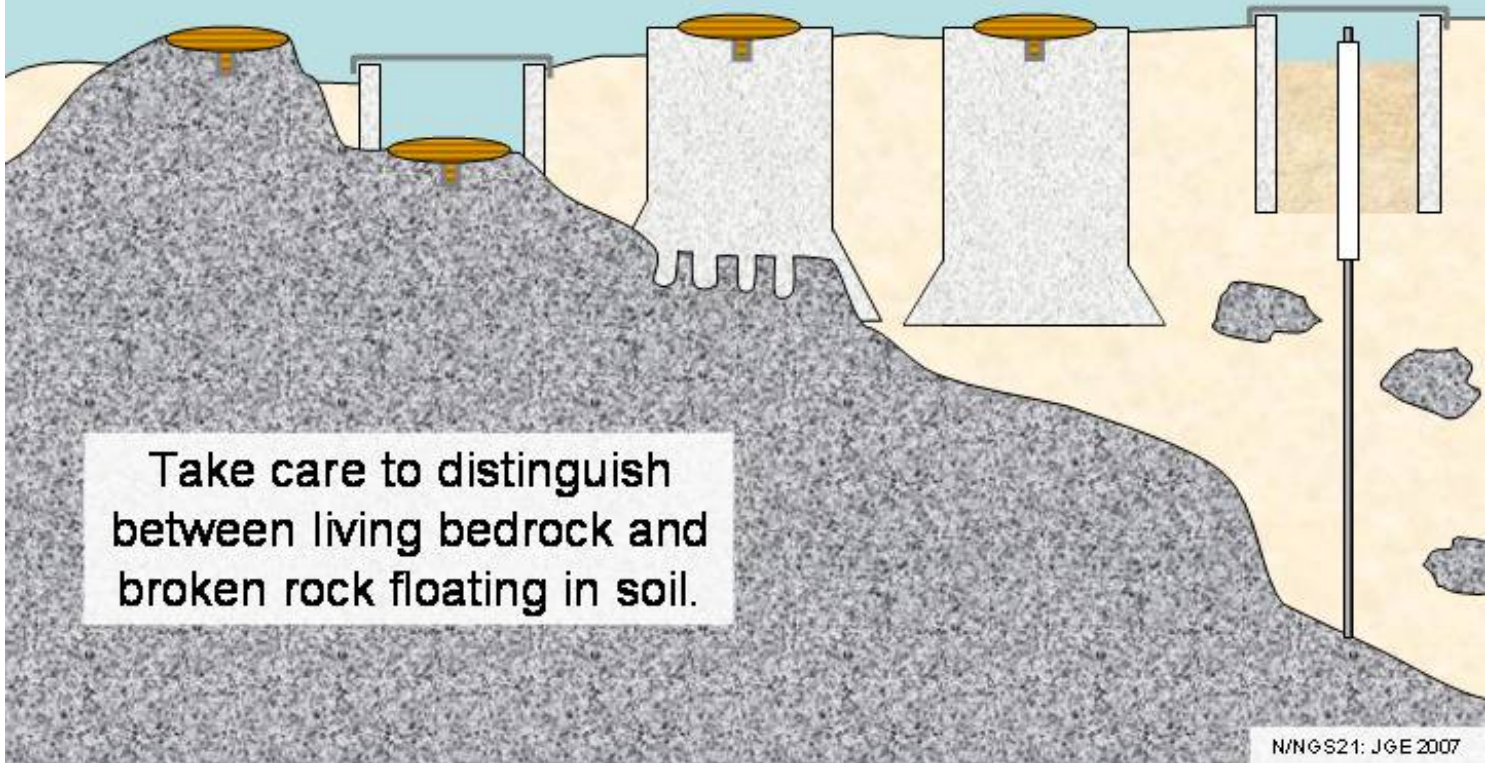

Take care to distinguish
between living bedrock and
broken rock floating in soil.

Version 1
January 22, 2008

ATTACHMENT Z
NGS REQUIREMENTS FOR TIDE GAUGE STATIONS

TO
SCOPE OF WORK FOR GROUND SURVEYS

NATIONAL GEODETIC SURVEY
NATIONAL OCEAN SERVICE
NATIONAL OCEANIC & ATMOSPHERIC ADMINISTRATION
U.S. DEPARTMENT OF COMMERCE

ATTACHMENT Z - NGS REQUIREMENTS FOR TIDE GAUGE STATIONS

GENERAL COMMENTS

DOCUMENT PRECEDENCE – In order of precedence: Project Instructions, this document, CMP SOW, “NOS HYDROGRAPHIC SURVEYS, SPECIFICATIONS AND DELIVERABLES” (HYDRO. SPECS.), Chapter 4 (April 2007), and other CO-OPS documents.

CORRECT NAME – Use the exact station designation (name) as found in NOAA records. For marks in the NGS database, use the designation on the NGS datasheet. For tidal bench marks not in the NGS database, use the designation as found on the tide station description. This means the same letters, same numbers, and same spaces.

UPPER CASE – Station names are always recorded using upper case letters.

STAMPING – Record the stamping exactly as on the disk or logo cap. Note, most stampings include the year set, but most station designations do not include the year. Never change the stamping on a disk or logo cap.

SPECIFICATIONS – Do not use the Height Modernization specifications in publication NOS NGS 58 for GPS observations on tidal bench marks, unless specifically directed in the Project Instructions.

NUMBER OF TIDAL BENCH MARKS

Five tidal bench marks are required at each tertiary tidal station (a tide gauge that will be in place between 1 month and 1 year), see HYDRO. SPECS. and CO-OPS document “USER’S GUIDE FOR THE INSTALLATION OF BENCH MARKS AND LEVELING REQUIREMENTS FOR WATER LEVEL STATIONS”, dated October 1987, Section 2.3.2. These five may include existing tidal bench marks, existing NGS geodetic bench marks, and existing marks of other organizations that meet NOAA standards, or any combination of the above. All tidal bench marks should be within one mile of the tide station (“USER’S GUIDE...”, page 5).

If a sufficient number of existing marks are not available, then new marks, meeting NOAA specifications, shall be set to reach a total of five. If none of the existing marks is capable of being occupied with GPS, then a new stability A or B mark should be set.

MARK SETTING

SITE SELECTION – See guidance in SOW, Attachment W, Section 3.1, HYDRO. SPECS., and CO-OPS document, “USER’S GUIDE FOR THE INSTALLATION OF BENCH MARKS AND LEVELING REQUIREMENTS FOR WATER LEVEL STATIONS,” Section 2.8.

STABILITY – At least one of the tidal BM should be NGS stability A or B

SETTING SPECIFICATIONS - All marks will be set according to NGS specifications.

DISKS IN CONCRETE see SOW, Attachment T.

DISKS IN BEDROCK see SOW, Attachment U.

STAINLESS STEEL RODS, see SOW, Attachment V.

MARK MATERIALS

DISKS - For tidal bench marks, use only brass disks with factory inscription including “NATIONAL OCEAN SERVICE BENCH MARK”

ROD MARKS - For rod marks use aluminum logo caps with factory inscription including "TIDAL BENCH MARK NATIONAL OCEAN SERVICE"

WITNESS POSTS – For Witness Posts use those with sticker containing the NOAA logo and printing including "FOR INFO WRITE TO THE DIRECTOR, NATIONAL OCEAN SERVICE DEPT. OF COMMERCE WASH., D.C."

NGS will supply these items upon request. All other mark setting supplies and equipment are the responsibility of the contractor.

MARK NAMING

Follow CO-OPS specifications for naming tidal bench marks. See HYDRO. SPECS. and "USER'S GUIDE FOR THE INSTALLATION OF BENCH MARKS AND LEVELING REQUIREMENTS FOR WATER LEVEL STATIONS," Section 2.7.

MARK DESCRIPTIONS & RECOVERY NOTES

NEW MARKS - Descriptions are required for all new marks set.

CASE 1, DESCRIPTIONS FOR ENTRY INTO NGS AND CO-OPS

DATABASES – Write the descriptions in NGS 3-paragraph format (see CMP SOW, Attachment S), using program WINDESC to create the digital descriptions. After saving the WINDESC files, delete the "To Reach" paragraphs from each tidal bench mark description and save the files as a MS Word files and PDF files. Save these for eventual submission to CO-OPS. Note, one copy of the "To Reach" paragraph shall also be saved in MS Word and PDF formats. Name this file per CO-OPS specifications in: "USER'S GUIDE FOR WRITING BENCH MARK DESCRIPTIONS", Page 1, second paragraph. (Marks in this category might include the tidal bench mark occupied with GPS and/or any geodetic bench marks that are leveled to.)

CASE 2 – DESCRIPTIONS FOR ENTRY INTO NGS DATABASE ONLY –

Create and submit digital descriptions using WINDESC. (Marks in this category might be geodetic bench marks that are occupied with GPS but not leveled to.)

CASE 3- DESCRIPTIONS FOR ENTRY INTO CO-OPS DATABASE ONLY –

Create descriptions in MS Word and PDF formats without "To Reach" paragraph and submit "To Reach" paragraph separately as in Case 1, above. (Marks in this category might be tidal bench marks that are leveled to but not occupied with GPS.)

RECOVERED MARKS – Prepare "Recovery Notes" following procedures similar to those in the Description section above.

Note, recovery notes are required for all marks searched for and found. See CMP SOW, Attachment S. In addition, see CO-OPS document, "USER'S GUIDE FOR WRITING BENCH MARK DESCRIPTIONS", dated January 2002 for guidance on unit conversions.

MARK PHOTOGRAPHS

All marks recovered and used shall have at least three digital photographs. See CMP SOW, Attachment R. Note, all photographs are submitted on a CD separate from other deliverables. In addition, follow CO-OPS requirements for photographs of tide gauge equipment, see Hydro. Specs, Section 4.2.10E.

SELECTION OF EXISTING BM FOR GPS TIES

PRIMARY BENCH MARK – Use the mark designated by CO-OPS as the Primary Bench Mark if possible.

VISIBILITY – An antenna set up over the mark must be able to receive satellite signals, see CMP SOW.

STABILITY – Marks occupied with GPS should be Stability “A” or “B”, see CMP SOW, Attachment W.

LEVELING TIES

BETWEEN TIDAL BENCH MARKS – Follow CO-OPS specifications for spirit level ties between tidal bench marks (BM) at a tide station, see HYDRO. SPECS., Section 4.2.9 and “USER’S GUIDE FOR THE INSTALLATION OF BENCH MARKS AND LEVELING REQUIREMENTS FOR WATER LEVEL STATIONS”.

BETWEEN GEODETIC BM AND TIDAL BM – If at least two geodetic BMs exist within 1 mile of the tide station, run spirit levels through at least two geodetic BM and at least one tidal BM. If less than two geodetic BM exist within one mile, no leveling is required, see “USER’S GUIDE FOR GPS OBSERVATIONS”, dated March 2007, Section 3.1.1.

LEVELING ACCURACY STANDARD – Third-Order permitted, see Hydro. Specs. Section 4.2.5.

VERTICAL TIES, BASED ON DISTANCE FROM TIDE STATION

GEODETIC BM LESS THAN 1 MILE – Leveling tie required; do leveling tie to two Geodetic BM.

GEODETIC BM OVER 1 MILE – No tie required.

GPS HORIZONTAL TIE SPECIFICATIONS

MARKS TO OBSERVE – Make static GPS observations on one tidal BM, the primary BM if possible (meets stability, etc. requirements).

EQUIPMENT - Use geodetic quality GPS receivers, fixed height poles, and GPS antennas that have had their phase center calibrated by NGS. See CMP SOW for additional details.

SESSION LENGTH – At least 4 hours, longer as possible, because high accuracy data is desired.

NUMBER OF SESSIONS – One required, two or more recommended.

DATA PROCESSING – Submit data to OPUS-DB for processing and entry into the NGS database..

GPS POSITIONING OF OTHER TIDAL BM - Determine horizontal positions for all other tidal bench marks using hand-held GPS or better method, see “USER’S GUIDE FOR GPS OBSERVATIONS”, Section 3.2.5.

METEOROLOGICAL DATA – Not required.

TIDE GAUGE INSTALLATION, SERVICING, REMOVAL – See HYDRO. SPECS.

TIDE DATA PROCESSING - See HYDRO. SPECS.

DATA SUBMISSION – Submit all reports and data to NGS. NGS will review and forward to CO-OPS.

TIMELINE FOR DATA SUBMISSION - 15 days