

NOAA Manual NOS NGS 3



Geodetic Leveling

National Geodetic Survey

Rockville, Md.

August 1981

Reprinted June 2001



U.S. DEPARTMENT OF COMMERCE

National Oceanic and Atmospheric Administration

National Ocean Survey

(

(

(

NOAA Manual NOS NGS 3



Geodetic Leveling

M. Christine Schomaker, Lt., NOAA
Ralph Moore Berry

National Geodetic Survey
Rockville, Md.
August 1981

Reprinted June 20001

Supersedes Coast and Geodetic Survey Special
Publication 239, Manual of Geodetic Leveling, 1948.

U.S. DEPARTMENT OF COMMERCE

Malcolm Baldrige, Secretary

National Oceanic and Atmospheric Administration

John V. Byrne, Administrator

National Ocean Survey

H. R. Lippold, Jr., Director

(

(

(

NOAA Manual NOS NGS 3

GEODETIC LEVELING

ABSTRACT: This manual furnishes instructions and background information suitable for establishing and maintaining vertical control. It presents general specifications and detailed instructions for (1) reconnaissance and bench mark setting, (2) geodetic leveling, (3) water and valley crossings, and (4) data processing in the field. These instructions should be used by field surveyors engaged in collecting elevation data for inclusion in the National Geodetic Vertical Network.

Mention of a commercial company or product does not constitute an endorsement by the National Oceanic and Atmospheric Administration. Use for publicity or advertising purposes of information from this publication concerning proprietary products or the tests of such products is not authorized.

(

(

(

CONTENTS

| | | |
|-------------------|--|------------|
| ABSTRACT | | ii |
| PREFACE | | iii |
| Chapter 1. | VERTICAL CONTROL NETWORKS | 1-1 |
| | 1.1 Introduction | 1-1 |
| | 1.2 Development of Geodetic Leveling | 1-1 |
| | 1.3 Height Systems | 1-3 |
| | 1.4 National Geodetic Vertical Control Network | 1-4 |
| Chapter 2. | RECONNAISSANCE AND BENCH MARK SETTING | 2-1 |
| | 2.1 Introduction | 2-1 |
| | 2.2 Organizing a Mark setting Unit | 2-1 |
| | 2.2.1 Personnel | 2-1 |
| | 2.2.2 Equipment | 2-2 |
| | 2.2.3 Safety | 2-2 |
| | 2.2.4 Reports | 2-2 |
| | 2.3 Routing a Line for Leveling | 2-4 |
| | 2.3.1 Preliminary Data | 2-4 |
| | 2.3.2 Liaison | 2-9 |
| | 2.3.3 Routing Specifications | 2-19 |
| | 2.3.4 Connections | 2-20 |
| | 2.3.5 Records | 2-23 |
| | 2.4 Vertical Control Points | 2-25 |
| | 2.4.1 Control Point Recovery | 2-25 |
| | 2.4.2 Bench Mark Setting | 2-26 |
| | 2.4.3 Assigning Geographic Positions | 2-28 |
| | 2.4.4 Descriptions | 2-34 |
| | 2.5 Relocating Vertical Control Points | 2-44 |
| | 2.6 References | 2-47 |
| Chapter 3. | GEODETIC LEVELING | 3-1 |
| | 3.1 Introduction | 3-1 |
| | 3.1.1 General Procedures | 3-1 |
| | 3.1.2 Sources of Error | 3-1 |
| | 3.1.3 Tolerances | 3-6 |
| | 3.2 Organizing a Leveling Unit | 3-6 |
| | 3.2.1 Personnel | 3-6 |
| | 3.2.2 Equipment | 3-8 |
| | 3.2.3 Safety | 3-9 |
| | 3.2.4 Reports | 3-9 |
| | 3.3 Leveling Instruments | 3-11 |
| | 3.3.1 Classification | 3-11 |
| | 3.3.2 Telescope System | 3-13 |
| | 3.3.3 Compensator System | 3-14 |
| | 3.3.4 Optical Micrometer | 3-22 |
| | 3.3.5 Use and Maintenance | 3-23 |
| | 3.3.6 Sighting Distance | 3-27 |
| | 3.3.7 Collimation Check | 3-29 |
| | 3.3.8 Compensation Check | 3-34 |
| | 3.4 Leveling Rods | 3-39 |
| | 3.4.1 Description | 3-39 |
| | 3.4.2 Calibration | 3-43 |
| | 3.4.3 Use and Maintenance | 3-44 |
| | 3.5 Turning Points | 3-46 |
| | 3.5.1 Selection and Use | 3-46 |
| | 3.5.2 Pacing Balanced Setups | 3-47 |
| | 3.6 Atmospheric Conditions | 3-49 |
| | 3.6.1 Air Temperature, Sun, and Wind | 3-49 |
| | 3.6.2 Leveling in Extreme Conditions | 3-50 |

CONTENTS—Continued

| | |
|---|------------|
| 3.7 Observing Routine | 3-51 |
| 3.7.1 General Instructions | 3-51 |
| 3.7.2 Micrometer Leveling | 3-53 |
| 3.7.3 Three-wire Leveling | 3-57 |
| 3.7.4 Precautions to Take at Control Points | 3-59 |
| 3.7.5 Leveling to Awkward Control Points | 3-62 |
| 3.7.6 Tide and Water-level Stations | 3-64 |
| 3.7.7 Releveling and Closing Sections | 3-65 |
| 3.8 Field Records | 3-66 |
| 3.8.1 Recording Observations | 3-66 |
| 3.8.2 Computer Recording Equipment | 3-68 |
| 3.8.3 Field Abstract | 3-69 |
| 3.8.4 Submitting Records to the Project Office | 3-72 |
| 3.9 References | 3-72 |
| | |
| Chapter 4. RIVER OR VALLEY CROSSING | 4-1 |
| 4.1 Introduction | 4-1 |
| 4.2 Preparations | 4-3 |
| 4.2.1 Reconnaissance and Mark setting | 4-4 |
| 4.2.2 Personnel | 4-4 |
| 4.2.3 Equipment | 4-5 |
| 4.2.4 Environmental Conditions | 4-5 |
| 4.3 Instructions for Zeiss River Crossing Equipment | 4-5 |
| 4.3.1 Description of Equipment | 4-5 |
| 4.3.2 Setups | 4-7 |
| 4.3.3 Observing Routine | 4-10 |
| 4.3.4 Final Computations | 4-16 |
| 4.4 Instructions for Ordinary Leveling Instruments | 4-17 |
| 4.4.1 Equipment and Setups | 4-17 |
| 4.4.2 Observing Routine for Two Targets (Three-wire Leveling) | 4-18 |
| 4.5 Reference | 4-22 |
| | |
| Chapter 5. DATA PROCESSING | 5-1 |
| 5.1 Introduction | 5-1 |
| 5.2 Organizing a Project Office | 5-1 |
| 5.2.1 Personnel | 5-1 |
| 5.2.2 Equipment for Data Processing | 5-1 |
| 5.2.3 Organizing the Data | 5-2 |
| 5.2.4 Submitting Data to the National Geodetic Survey | 5-3 |
| 5.3 Processing Descriptions | 5-7 |
| 5.3.1 Creating the Description File | 5-7 |
| 5.3.2 Checking Individual Descriptions | 5-7 |
| 5.3.3 Checking the Entire File | 5-10 |
| 5.4 Processing Leveling Data | 5-13 |
| 5.4.1 Checking Observation Records | 5-13 |
| 5.4.2 Checking the Field Abstract | 5-15 |
| 5.4.3 Preliminary Analysis | 5-20 |
| 5.4.4 Statistics | 5-23 |
| 5.5 Verification and Adjustment | 5-23 |
| 5.5.1 Quality Control Review | 5-23 |
| 5.5.2 Computing Corrections | 5-24 |
| 5.5.3 Adjustment | 5-26 |
| 5.6 References | 5-27 |
| | |
| APPENDIX A. LISTS OF EQUIPMENT | A-1 |
| APPENDIX B. INDEX OF GEODETIC CONTROL DIAGRAMS | B-1 |
| APPENDIX C. STANDARD GEODETIC LEVELING FORMS | C-1 |
| INDEX | I-1 |

FIGURES

Chapter 1

| | | |
|-------------|---|-----|
| Figure 1-1. | Orthometric height, H , on a surface not parallel to the reference surface | 1-3 |
| Figure 1-2. | Observed difference in orthometric height, ΔH , depends on the leveling route | 1-3 |
| Figure 1-3. | Basic net A of the National Geodetic Vertical Network | 1-6 |

Chapter 2

| | | |
|---------------|--|------|
| Figure 2-1. | Mark setting monthly report | 2-3 |
| Figure 2-2. | Scale relationships of preliminary data | 2-5 |
| Figure 2-3. | Example of line assignments in project instructions | 2-5 |
| Figure 2-4. | State Index Map of Control Leveling | 2-6 |
| Figure 2-5. | Geodetic Control Diagram | 2-7 |
| Figure 2-6. | Index to Topographic Maps, project lines plotted | 2-8 |
| Figure 2-7a. | Index plot for 30' quadrant of Vertical Control Data | 2-10 |
| Figure 2-7b. | Vertical Control Data sheet | 2-11 |
| Figure 2-7c. | Alphanumeric indexes for 30' quadrant of Vertical Control Data | 2-12 |
| Figure 2-7d. | Line order index for 30' quadrant | 2-13 |
| Figure 2-8a. | Listing of synoptic file | 2-14 |
| Figure 2-8b. | Listing of synoptic file | 2-15 |
| Figure 2-9a. | Form letter distributed to property owners | 2-17 |
| Figure 2-9b. | Form letter distributed to property owners | 2-18 |
| Figure 2-10. | Network junctions | 2-19 |
| Figure 2-11. | Locations for monuments of the best possible quality | 2-20 |
| Figure 2-12. | Connections to parallel surveys | 2-22 |
| Figure 2-13. | Connections to intersected surveys | 2-23 |
| Figure 2-14. | Connections to an area survey | 2-23 |
| Figure 2-15. | Map prepared on a working plot | 2-24 |
| Figure 2-16. | Example of bench mark designations assigned by mark setter | 2-26 |
| Figure 2-17. | Foundation types of massive bridges | 2-27 |
| Figure 2-18. | Driving point for a rod mark | 2-28 |
| Figure 2-19. | Stainless steel cap for a rod mark | 2-28 |
| Figure 2-20. | Tools for scaling geographic positions | 2-30 |
| Figure 2-21. | Scaling latitude: D 59 USLS is $42^{\circ} 01' 33''$ N | 2-31 |
| Figure 2-22. | Scaling longitude: D 59 USLS is $83^{\circ} 13' 32''$ W | 2-32 |
| Figure 2-23. | Smooth plot | 2-33 |
| Figure 2-24. | Complete description | 2-35 |
| Figure 2-25a. | Recovery note | 2-36 |
| Figure 2-25b. | Recovery note | 2-37 |
| Figure 2-26. | Survey disks of the former U.S. Coast and Geodetic Survey | 2-42 |
| Figure 2-27. | Survey disks of the National Ocean Survey and National Geodetic Survey | 2-43 |
| Figure 2-28. | Report on the condition of a survey point | 2-45 |
| Figure 2-29. | Report of a relocated bench mark | 2-46 |

Chapter 3

| | | |
|--------------|---|------|
| Figure 3-1. | Setup of leveling, $\Delta h = B - F$ and $s = s_B + s_F$ | 3-1 |
| Figure 3-2. | Section of leveling, $\Delta H = \Delta h_1 + \Delta h_2 + \dots + \Delta h_n$ and $S = s_1 + s_2 + \dots + s_n$ | 3-2 |
| Figure 3-3. | Effect of collimation error, α | 3-2 |
| Figure 3-4. | Consistent collimation error cancels in a balanced setup since $s_B = s_F$ | 3-2 |
| Figure 3-5. | Inconsistent collimation error does not cancel in a balanced setup since $\alpha_B \neq \alpha_F$, even if $s_B = s_F$ | 3-3 |
| Figure 3-6. | Shimmer | 3-3 |
| Figure 3-7. | Refraction error, r , does not cancel on sloping terrain since $r_B \neq r_F$, even if $s_B = s_F$ | 3-3 |
| Figure 3-8. | Curvature error, c , where the line of sight is not parallel to an equipotential surface, cancels if $s_B = s_F$ | 3-4 |
| Figure 3-9. | Effect, a , of tidal deflection, ϵ , on a section of length and direction, \overline{S} | 3-4 |
| Figure 3-10. | Effect of rod plumbing error, ρ , on a height observation, B | 3-4 |
| Figure 3-11. | Systematic effect of plumbing error (and scale errors) is small on flat terrain, since $B_1 \cong F_2$ and $F_1 \cong B_2$ | 3-5 |
| Figure 3-12. | Effect of plumbing error (and scale errors) accumulates on sloping terrain, since $B_1 \neq F_2$ and $F_1 \neq B_2$ | 3-5 |
| Figure 3-13. | Controlling traffic | 3-10 |
| Figure 3-14. | Leveling unit weekly report | 3-11 |

FIGURES-Continued

| | | |
|-----------------|--|------|
| Figure 3-15. | Leveling unit monthly report | 3-12 |
| Figure 3-16. | Fischer level | 3-13 |
| Figure 3-17. | Jenoptik Ni004 | 3-13 |
| Figure 3-18. | Zeiss Ni2, with micrometer attachment | 3-14 |
| Figure 3-19. | Zeiss Ni1 | 3-14 |
| Figure 3-20. | MOM NiA31 | 3-14 |
| Figure 3-21. | Jenoptik NI 002 | 3-15 |
| Figure 3-22. | External-focusing telescope | 3-16 |
| Figure 3-23. | Internal-focusing telescope | 3-16 |
| Figure 3-24. | Ni2 compensator system, telescope axis horizontal | 3-17 |
| Figure 3-25. | Ni2 compensator system, telescope axis tilted | 3-18 |
| Figure 3-26. | Deflection of the line of collimation by the compensator | 3-18 |
| Figure 3-27. | Condition for dynamic stability of the Ni2 | 3-19 |
| Figure 3-28. | Ni1 compensator system, telescope axis horizontal | 3-19 |
| Figure 3-29. | Ni1 compensator system, telescope axis tilted | 3-20 |
| Figure 3-30. | Diagram of the NI 002 | 3-21 |
| Figure 3-31. | Lines of sight provided by the NI 002 | 3-22 |
| Figure 3-32. | Snell's law applied to a plane-parallel plate micrometer | 3-23 |
| Figure 3-33. | Plane-parallel plate unrotated | 3-23 |
| Figure 3-34. | Plane-parallel plate rotated to intercept a graduation | 3-24 |
| Figure 3-35. | Plane-parallel plate micrometer scale | 3-25 |
| Figure 3-36. | Carrying the instrument-tripod assembly | 3-25 |
| Figure 3-37. | Centering the bubble in a circular level | 3-25 |
| Figure 3-38. | Wedge reticle, graduation not centered | 3-26 |
| Figure 3-39a/b. | Wedge reticle, graduation centered | 3-27 |
| Figure 3-40. | Relationship of stadia interval to sighting distance | 3-28 |
| Figure 3-41. | Stadia factor determination, micrometer procedure, half-centimeter rods | 3-30 |
| Figure 3-42. | Stadia factor determination, three-wire procedure, centimeter rods | 3-30 |
| Figure 3-43. | Collimation check, Kukkamaki's method | 3-32 |
| Figure 3-44. | Collimation check, Kukkamaki's method, micrometer procedure, half-centimeter rods, reversible compensator | 3-33 |
| Figure 3-45. | Collimation check, Kukkamaki's method, micrometer procedure, centimeter rods, nonreversible compensator | 3-34 |
| Figure 3-46. | Collimation check, Kukkamaki method, three-wire procedure, half-centimeter rods | 3-35 |
| Figure 3-47. | Collimation check, 10-40 method | 3-36 |
| Figure 3-48. | Collimation check, 10-40 method, micrometer procedure, half-centimeter rods, reversible compensator | 3-37 |
| Figure 3-49. | Collimation check, 10-40 method, micrometer procedure, centimeter rods, nonreversible compensator | 3-37 |
| Figure 3-50. | Collimation check, 10-40 method, three-wire procedure, centimeter rods | 3-38 |
| Figure 3-51. | Compensation check for the Ni1 and half-centimeter rods | 3-39 |
| Figure 3-52. | Compensation check, micrometer leveling, half-centimeter rods | 3-40 |
| Figure 3-53. | Compensation check, micrometer leveling, centimeter rods | 3-40 |
| Figure 3-54. | Inverted scale for a leveling rod | 3-41 |
| Figure 3-55. | Double scale with half-centimeter line graduations | 3-42 |
| Figure 3-56. | Leveling rods with block graduations | 3-42 |
| Figure 3-57. | Brace poles for a leveling rod | 3-43 |
| Figure 3-58. | Rod calibration data | 3-43 |
| Figure 3-59. | Carrying the leveling rod | 3-44 |
| Figure 3-60. | Turning-point guide | 3-44 |
| Figure 3-61. | Setup of leveling rod | 3-45 |
| Figure 3-62. | Tracings for checking the adjustment of the circular level | 3-46 |
| Figure 3-63. | Turning pin (a) and hammer (b) | 3-47 |
| Figure 3-64. | Turning pin dimensions | 3-47 |
| Figure 3-65. | Turning plate | 3-48 |
| Figure 3-66. | Hand level | 3-49 |
| Figure 3-67. | Pacing a balanced setup on a slope | 3-49 |
| Figure 3-68. | Thermometer, mounted on tripod | 3-49 |
| Figure 3-69. | Aspirated thermistors for measuring air-temperature differences | 3-50 |
| Figure 3-70. | Micrometer leveling, backup form for a computer-recording system | 3-54 |

FIGURES-Continued

| | | |
|----------------------|--|------|
| Figure 3-71. | Micrometer leveling, half-centimeter rods | 3-55 |
| Figure 3-72. | Micrometer leveling, centimeter rods..... | 3-55 |
| Figure 3-73. | Three-wire leveling, half-centimeter rods..... | 3-58 |
| Figure 3-74. | Three-wire leveling, centimeter rods | 3-58 |
| Figure 3-75. | Leveling routes through a cluster of control points at a triangulation station (a) and a tide station (b) | 3-60 |
| Figure 3-76. | Control points on horizontal surfaces (a) and vertical surfaces (b)..... | 3-61 |
| Figure 3-77. | When using spacers the height, e , of each spacer cancels when the elevation difference, Δh , is computed: $\Delta h = (B + e) - (F + e) = B - F$ | 3-62 |
| Figure 3-78. | Leveling to awkward control points..... | 3-62 |
| Figure 3-79. | Leveling directly to a control point | 3-63 |
| Figure 3-80. | Short scale | 3-64 |
| Figure 3-81. | Centering the index line of a short scale on a control point | 3-64 |
| Figure 3-82. | Leveling to an upside-down scale | 3-65 |
| Figure 3-83. | Leveling line identification | 3-70 |
| Figure 3-84. | Sketch of single-run leveling..... | 3-71 |
| Figure 3-85. | Abstract of single-run leveling | 3-71 |
| Figure 3-86. | Sketch of double-run leveling | 3-71 |
| Figure 3-87. | Abstract of double-run leveling | 3-71 |
| Chapter 4 | | |
| Figure 4-1. | Curvature, c , refraction, r , and the effect, $C \times s$, of collimation error, α , are magnified by a long sighting distance | 4-1 |
| Figure 4-2. | Intercepting two targets to reduce pointing error | 4-2 |
| Figure 4-3. | The effects of curvature, c , cancel if a pair of reciprocal setups are observed and the results, Δh_A and Δh_B , are meaned | 4-3 |
| Figure 4-4. | The effects of refraction, r , cancel when the results of a set of simultaneous, reciprocal observations are meaned; however, the collimation error of one instrument, α_1 , is only partly offset by the collimation error of the other instrument, α_2 | 4-3 |
| Figure 4-5. | Simultaneous reciprocal observations with four leveling instruments, the two instruments on each side having reciprocal collimation errors | 4-4 |
| Figure 4-6. | Rotary wedge, unrotated (a) and rotated (b) | 4-6 |
| Figure 4-7. | Rotary wedge scale | 4-7 |
| Figure 4-8. | Target column | 4-7 |
| Figure 4-9. | Targets mounted on target column | 4-8 |
| Figure 4-10. | Using the auxiliary scale | 4-8 |
| Figure 4-11. | Setups for Zeiss River Crossing Equipment, top view (a) and side view (b). $\Delta h = \frac{1}{2}[(\Delta h_{\text{Series A}} + \Delta h_{\text{Leveling B}}) - (\Delta h_{\text{Series B}} + \Delta h_{\text{Leveling A}})]$ | 4-9 |
| Figure 4-12. | Instruments mounted on base plate | 4-10 |
| Figure 4-13. | Leveling from the nearby target station to the nearby bench mark, forward (a) and backward (b) | 4-12 |
| Figure 4-14. | Annotated recording form for the series of observations from the nearby bench mark to the opposite target station | 4-13 |
| Figure 4-15. | Series from the nearby bench mark to the opposite target station | 4-14 |
| Figure 4-16. | Reciprocal collimation, before (a) and after (b) | 4-15 |
| Figure 4-17. | Backsight, wedge settings on rod graduations | 4-15 |
| Figure 4-18. | Foresight, wedge settings on targets | 4-16 |
| Figure 4-19. | Computation of river crossing with Zeiss River Crossing Equipment | 4-18 |
| Figure 4-20. | Setups for simultaneous reciprocal observations with ordinary leveling instruments, top view (a) and side view (b). $\Delta H = \frac{1}{2}(\Delta h_{\text{Set 1}} + \Delta h_{\text{Set 2}})$ | 4-19 |
| Figure 4-21. | Fischer level, with micrometer tilting screw | 4-20 |
| Figure 4-22. | One side of a set of simultaneous reciprocal observations, three-wire leveling | 4-21 |
| Figure 4-23. | Cover sheet for a running with ordinary equipment | 4-22 |
| Chapter 5 | | |
| Figure 5-1. | Sample label for project records..... | 5-3 |
| Figure 5-2. | Sample memorandum releasing data | 5-4 |
| Figure 5-3a. | Sample form (NOAA 61-29) accompanying transmitted data | 5-5 |
| Figure 5-3b. | Sample form (NOAA 61-29) accompanying transmitted data | 5-6 |
| Figure 5-4. | Flow chart of project data processing..... | 5-8 |
| Figure 5-5. | Flow chart of data files for a line of leveling | 5-9 |

FIGURES-Continued

| | | |
|--------------|--|------|
| Figure 5-6. | Sample check-off list for station-description editing | 5-10 |
| Figure 5-7. | Example of a proofread station description | 5-10 |
| Figure 5-8. | Example of description of file status sheet | 5-11 |
| Figure 5-9. | Examples of apparent position errors | 5-12 |
| Figure 5-10. | Example of observation file status sheet | 5-14 |
| Figure 5-11. | Example of abstract status sheet | 5-16 |
| Figure 5-12. | Sample of computer-produced field abstract | 5-18 |
| Figure 5-13. | Samples of incorrect survey-point serial numbers. Mismatched survey-point serial numbers are underlined | 5-19 |
| Figure 5-14. | Example of comparisons between new-minus-old observed elevations | 5-21 |
| Figure 5-15. | Sample plot of new-minus-old values for observed elevations | 5-22 |
| Figure 5-16. | Sample sketch for checking a loop | 5-22 |
| Figure 5-17. | Combining loops | 5-23 |
| Figure 5-18. | Sample corrections applied in phase 1 of office abstract | 5-25 |
| Figure 5-19. | Sample profile of a leveling line | 5-27 |

TABLES

Chapter 1

| | | |
|------------|---|-----|
| Table 1-1. | Classification of vertical control networks | 1-5 |
|------------|---|-----|

Chapter 2

| | | |
|-------------|--|------|
| Table 2-1. | Preliminary data for reconnaissance and mark setting | 2-4 |
| Table 2-2. | Location codes for tide and water-level stations | 2-16 |
| Table 2-3. | Spacing control points along slopes | 2-20 |
| Table 2-4. | Requirements for connections | 2-21 |
| Table 2-5. | Standard entries for descriptions | 2-34 |
| Table 2-6. | Examples of bench mark designations | 2-39 |
| Table 2-7. | Agency classification codes | 2-40 |
| Table 2-8. | Control classification codes | 2-41 |
| Table 2-9. | Monument classification codes | 2-41 |
| Table 2-10. | Bench mark classification codes | 2-42 |

Chapter 3

| | | |
|------------|---|------|
| Table 3-1. | Tolerances for geodetic leveling | 3-7 |
| Table 3-2. | Features of some geodetic leveling instruments | 3-15 |
| Table 3-3. | Refraction and curvature errors in a single sight | 3-31 |
| Table 3-4. | Checklist for leveling | 3-52 |
| Table 3-5. | Summary of the micrometer leveling procedure | 3-56 |
| Table 3-6. | Summary of the three-wire leveling procedure | 3-59 |
| Table 3-7. | Example of rejection procedure for first-order, class II leveling | 3-67 |
| Table 3-8. | U.S. Navy time zone designations | 3-67 |

Chapter 4

| | | |
|------------|--|------|
| Table 4-1. | Summary of the crossing routine for Zeiss River Crossing Equipment | 4-11 |
| Table 4-2. | Data set for a complete crossing with Zeiss River Crossing Equipment | 4-17 |
| Table 4-3. | Summary of the crossing routine for ordinary leveling instruments | 4-21 |

Appendix B

| | | |
|------------|---|-----|
| Table B-1. | Codes for NGS Geodetic Control Diagrams | B-1 |
|------------|---|-----|

Chapter 1

VERTICAL CONTROL NETWORKS

1.1 Introduction

Since ancient times, the ability to locate widely separated points on the Earth's surface has been of vital interest to public commerce and defense. Accurate positioning has become increasingly important to construction, boundary definition, navigation, and the prediction and monitoring of changes in the topography. To provide accurate positions over the entire globe, a detailed knowledge about the size and shape of the Earth is critical. The pursuit of this knowledge is the science of geodesy.

Traditionally, points on the surface of the Earth have been located by assigning geographic positions and elevations. Geographic position (latitude and longitude) is determined by surveying techniques such as triangulation, trilateration, and traverse, which determine horizontal distances and directions between points. Elevations are obtained by techniques that determine vertical differences between points. These include differential leveling, trigonometric leveling, and observing changes in atmospheric pressure. Modern satellite and inertial systems determine geometric distances, in three dimensions, that can be converted to both geographic positions and elevations above an ellipsoid.

Because of the differences in surveying techniques, separate networks of horizontal and vertical control have evolved. However, all geodetic networks have in common the fact that measurements are made with instruments oriented to the Earth's gravity field.

An interconnected system of points, each of which is assigned an elevation referred to a common surface, is called a vertical control network. Since geodetic leveling has in the past provided, and continues to provide, the most accurate means for measuring precise elevation differences, a vertical network typically consists of lines of control points, reflecting the progression of leveling from point to point.

Vertical control networks provide elevations for many purposes: from localized construction projects to studies of widespread motions of the Earth's crust. To establish a sufficiently accurate national network, survey techniques must be of geodetic quality: they must employ accurate equipment, maintain a high degree of precision when extended over large areas, and adequately define the gravity field.

1.2 Development of Geodetic Leveling

Leveling was successfully employed by the ancient Egyptians who attempted to connect the Nile River with the Red Sea, by the Babylonians who constructed an

extensive irrigation system in the Euphrates Valley, and by the Romans who constructed extensive networks of aqueducts, both in Rome and such regions as Spain and the Middle East. In these cases, however, leveling depended on crude instruments that had provision for sighting along a water surface or that operated by some mechanical application of a plumb line.

The development of geodetic leveling as it is conducted today depended on the invention of three important items: the telescope, the reticle, and the level.

The invention of the telescope in 1608 is attributed to Lippershey, a Dutch spectacle maker. It was first used for scientific purposes by Galileo Galilei in 1609 for magnifying the image of a distant object, but it was not very useful as a pointing device until the introduction of the reticle.

The invention of the reticle, which provides "cross hairs" at the common focus of the objective lens and the ocular lens, was not possible until the invention of the "positive" ocular lens by Johann Kepler in 1611 and the actual placement of a measuring device at the common focus by the English astronomer William Gascoigne in 1639. In 1669, while working on a project to measure the length of a degree of latitude for the Royal Academy of France, Jean Picard first placed a reticle in a surveying instrument.

The invention of the level—a tube of glass with fluid sealed inside in such a way that a bubble is formed—is credited to Melchisedech Thevenot, who published information on instrumental details and manufacturing methods in 1666. Nearly a hundred years later, after procedures were perfected to manufacture level vials with uniform curvature, the telescope, reticle, and level were assembled in a spirit-level instrument similar to the one still used today in construction work. It is believed that such instruments were devised independently by Antoine de Chezy, a road and bridge engineer in France, and by Jesse Ramsden, a mathematical instrument maker in England.

Further developments in leveling are evident in early texts, such as Love's classical *Geodaesia* published in 1760, which recommends, under the heading "How to know whether water may be made to run from a Spring head to any appointed place," that: "It is better to get a water-level, such as you may buy at the Instrument-Makers." Later texts, such as the *Complete Manual of Leveling* by Simms, published in England in 1836, treat subjects such as corrections for curvature and refraction, and the calculation of earthwork from cross sections observed with a spirit-level instrument. References are made to both the "Y" level and the dumpy level,

instrumental designs which are familiar to twentieth-century engineers. The "Y" level is believed to have been invented in 1740 by Jonathan Simmons of London, and the dumpy level in 1845 by William Gavatt in England.

The first leveling in Europe that is considered of geodetic quality was conducted in France under the direction of M. Bourdaloue between 1857 and 1860. His results were published in 1864. The complex observing procedure was designed to produce results with a high degree of accuracy by eliminating systematic errors and detecting and eliminating blunders. This work is said to have required that every two measurements agree to within $2\sqrt{K}$ millimeters, where K was the length of the leveling line in kilometers.

The French work inspired the Swiss to engage in a similar effort. In 1864, a Swiss recommendation for the execution of a precise leveling network over a large part of Europe was adopted by the International Geodetic Conference. The methods of observation and the use of a mean sea-level datum were prescribed in the resolution. For the observations, a precise spirit-level instrument was designed by Kern of Aarau, Switzerland. These instruments were widely used in Europe and later several were used by the U.S. Corps of Engineers.

Although some leveling was undoubtedly conducted locally in the United States (primarily to tidal bench marks) prior to the Revolutionary War and by the U.S. Coast Survey upon its establishment in 1807, the first recorded effort was a geodetic leveling project by the U.S. Coast Survey in 1856-57. To support detailed studies of the tides and currents in New York Bay and the Hudson River, a series of tide gages was established along the Hudson River which connected with a line of leveling established by G. B. Vose. Vose states in the *1857 Report of the Superintendent of the Coast Survey*: "As you directed, a double series of levelings were made throughout the whole route and every doubtful step was retraced... It appears that the probable error for the entire distance from New York to Greenbush does not exceed two-tenths of a foot." A bench mark in this line provided the sea-level datum to which subsequent levelings by the U.S. Lake Survey were referred in determining elevations of the water surfaces in the Great Lakes.

In 1871 the Coast Survey formulated plans for a transcontinental arc of triangulation along the 39th Parallel. It quickly became apparent that accurate elevations would be required to reduce the triangulation data along the route. After Congress authorized the survey in 1876, new leveling instruments were designed and fabricated by the Coast Survey. These were used on the first transcontinental leveling in 1875. The first bench mark was set in the courthouse at Hagerstown, Md.

The line of "geodesic" leveling proceeded west with interruptions, reaching St. Louis, Mo., in 1882. A line leveled in 1881 from a tide gage at Sandy Hook, N. J.,

to Hagerstown, Md., provided a connection to mean sea level. In 1899 the transcontinental line reached within a few miles of Cheyenne, Wyo., and it was completed to the tide gage at Seattle, Wash., in 1905. Other lines were leveled, in cooperation with the Corps of Engineers, along portions of the Mississippi River and its major tributaries.

In 1875 the U.S. Lake Survey, requiring accurate elevations above mean sea level for the water levels in the Great Lakes and for bench marks in the adjacent harbor areas, extended geodetic leveling into the Great Lakes area. A line of control points was leveled in New York along the Erie Canal, various wagon roads, and the New York and Oswego Midland Railroad. The line extended from bench mark GRISTMILL, at the town of Greenbush, to bench mark A at the harbor in Oswego. During the same year, lines were leveled between Lake Ontario and Lake Erie, and a single line of leveling connected Lake Erie with Lake Huron. Thus, connections were made across the land between the Hudson River, Lake Ontario, Lake Erie, Lake Huron, and Lake Michigan.

An important procedure introduced in 1875 was water-level transfer in which the mean surface of each lake, averaged from data obtained at water-level gages during a 3- to 4-month period, was assumed to define an equipotential surface. An elevation relative to mean sea level, determined by leveling to a gage on a lake, was thus transferable to other gages on the lake. By this step-by-step process an elevation relative to mean sea level at Greenbush, N.Y., was assigned to the gage at Escanaba, Mich. For the first time, reasonably accurate elevations were available for all of the Great Lakes, except Lake Superior, based on the results of geodetic leveling and water-level transfers.

In 1877 the principle of "double-simultaneous" leveling was introduced along the Mississippi River by the Corps of Engineers. Two pairs of rods were used with one leveling instrument. The line of leveling was carried forward at each instrument setup with two independent observations of the backsight and foresight rods, on separate turning points. Thus, two separate levelings of the route were made, although only one observer and one leveling instrument were required. This provided continuous and effective checks against blunders as the work progressed. In 1882-83, J. B. Johnson of the Corps of Engineers introduced the observing procedure known as three-wire leveling.

In 1896 Congress authorized the U.S. Geological Survey to determine elevations in support of topographic mapping "above a base level located in each area under survey." Leveling was conducted in many States under this authorization. The first, and very important, line started at a tide gage at Morehead City, N.C., continued inland across the State through Raleigh, Greensboro, and Asheville; ran across Tennessee through Knoxville and Cleveland; extended southward into Georgia through Rome, Atlanta, and Macon, and ended on a tide gage at Brunswick, Ga.

Important contributions to the growing network of geodetic leveling were also made by railroad companies, which relied on leveling to support the construction and maintenance of their extensive track systems. Principal contributors were the Pennsylvania Railroad and the Baltimore and Ohio Railroad. In addition, almost all of the early leveling by the Federal Government was performed along railroad routes because they provided almost the only available cleared routes without excessively steep grades.

In 1898 an *ad hoc* committee of the Coast and Geodetic Survey (C&GS) was appointed to investigate the instruments, observational procedures, and results of geodetic leveling. After extensive analysis, the committee recommended a new design for the leveling instrument that had been used since 1877 and the adoption of the three-wire leveling procedures used by the Corps of Engineers. In 1899 three prototypes, modifications of the 1877 instruments, were produced in the C&GS shops and tested in the field.

The new spirit-level instrument was first used in 1900. It became known as the Fischer level, named for E. G. Fischer, chief of the C&GS Instrument Division, who was responsible for its design and manufacture. The instrument was designed to be very rigid and to change little in adjustment during temperature variations. Its freedom from mechanical failures and its high degree of accuracy soon became apparent.

The Fischer level was the standard leveling instrument of the Coast and Geodetic Survey until the mid-1960's when it was replaced by instruments equipped with optical micrometers.

Since 1900 further improvements in accuracy have been possible. These resulted from the introduction of Invar scales for leveling rods in 1917, instruments with optical micrometers in 1910, and compensator instruments in 1950. These features are still important today

1.3 Height Systems

Before a network of geodetic leveling may be considered a network of vertical control, the observed elevation differences must be placed within a common frame of reference. The first step is taken when the differences are measured after leveling an instrument and a pair of rods; all measurements are then relative to the direction of gravity. The second step is to minimize discrepancies in the results obtained by leveling along different routes between the same two points. For this process, termed adjustment, an appropriate height system must be selected to account for the nonspherical and irregular nature of the gravity field. The third step is to define the surface datum to which heights may be referred.

Orthometric height. The gravity field can be represented as a series of surfaces of equal potential, termed "level" or equipotential surfaces, one of which is specified as the reference surface from which orthometric

heights are measured. The orthometric height of a point is the distance from the projection of the point on the reference surface to the point itself, along a line perpendicular to every equipotential surface in between.

If an equipotential surface were consistently parallel to the reference surface, the orthometric height of every point on the surface would be the same. However, because of the Earth's rotation and anomalies in the gravity field itself, the equipotential surfaces defined by the gravity field are not parallel. The orthometric heights of points on a common equipotential surface vary, increasing most noticeably as a person moves towards the equator (fig. 1-1). For example, a level surface 1000 m above mean sea level at the Equator would be only 995 m above mean sea level at the poles.

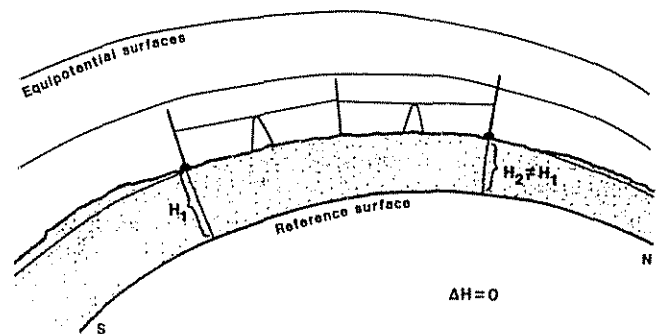

Figure 1-1.—Orthometric height, H , on a surface not parallel to the reference surface.

As a result, even though no elevation difference is measured when leveling between two points on an equipotential surface, the orthometric heights of the points are different if the points are at different latitudes. The elevation computed for the second point, by adding the observed elevation difference to the elevation of the first point, is not the orthometric elevation of the second point.

Furthermore, if the leveling follows a different route between the same two points, along a series of different equipotential surfaces, yet another elevation will be computed for the second point (fig. 1-2).

To obtain orthometric elevations that are consistent with respect to a single reference surface, this effect

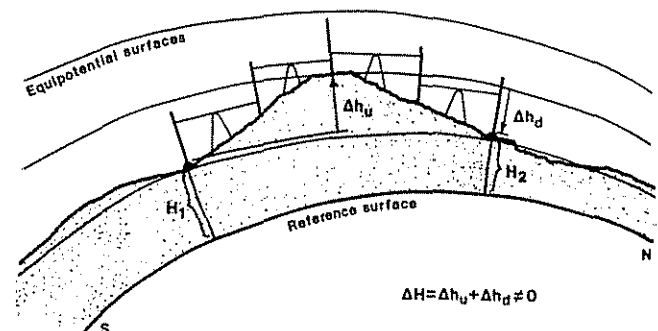

Figure 1-2.—Observed difference in orthometric height, ΔH , depends on the leveling route.

must be removed. One way is to correct the elevation difference for each section of leveling, subtracting the error predicted by using a model of the Earth's normal gravity field. (See end of sec. 5.5.2.) The elevations obtained in this manner are termed normal orthometric heights.

Geopotential number. A more accurate way to account for the effect of the gravity field is to compute geopotential numbers rather than orthometric heights. The geopotential number of a point is a measure of the difference in potential from the reference surface to the equipotential surface passing through the point. It is numerically equivalent to the work required to raise a mass of 1 kg against gravity, g , through the orthometric height, H , to the point:

$$\text{Geopotential number} = \int_0^H g dh.$$

The difference in height, dh , measured during each setup of leveling, may be converted to a difference in potential by multiplying it by the mean value of gravity for the setup. To compute accurate geopotential numbers, gravity must be determined with sufficient accuracy and density throughout the vertical network. Only since the development of the modern gravimeter has this become practical.

Although geopotential numbers are useful for the adjustment of vertical networks, for many purposes orthometric heights above a physically defined reference surface are still necessary. A geopotential number may be converted to an orthometric height by dividing it by the mean value of gravity along the plumb line between the point and the reference surface. Since such a value cannot be directly measured (because the reference surface lies within the Earth beneath the point), a model must be used to derive the value as a function of the geographic position, measured value of gravity at the point, and other variables.

Datums. Traditionally, mean sea level has been selected as the reference surface for computing heights because a water surface conforms to the gravity field by approximating an equipotential surface. A point on mean sea level is determined at a tide gage, where the fluctuations of water level are observed for many years to assess tidal effects adequately. If the elevation at such a gage is connected to a leveling network, and zero is fixed as the height of mean sea level, the reference surface thus defined is called a sea-level datum.

However, a variety of physical factors—changes in volume, currents, temperature and salinity gradients, atmospheric pressure, wind, and sea-floor topography—affect the mean water level determined at each tide gage. As a result, the points assigned to be on mean sea level at different tide gages do not necessarily lie on the same equipotential surface.

To avoid the implication that an elevation difference of zero will be obtained when leveling between two widely separated tide gages, the reference surface is simply referred to as the datum. It can be defined in many

different ways that may or may not refer to mean sea level. As described in the following paragraphs, the datum of the National Geodetic Vertical Network has always been defined by a mean sea level. It has changed with each adjustment as additional tide gages have been connected.

1.4 National Geodetic Vertical Network

By 1900 geodetic leveling by the Coast and Geodetic Survey and other agencies had become so extensive that a general adjustment of the results became necessary to obtain consistent and accurate elevations for all control points. Data from 21,095 km of leveling were obtained by the Coast and Geodetic Survey from the U.S. Geological Survey, the Corps of Engineers (U.S. Lake Survey, Mississippi River Commission, Missouri River Commission, Deep Waterways Commission, and others), and the Pennsylvania Railroad.

The adjustment of this, the first national network, produced elevations for about 4,200 control points that were referred to mean sea level as determined at the following tide gages: Boston, Mass., New York, N. Y., Sandy Hook, N.J., Washington, D.C., and Biloxi, Miss. A connection to sea level on the Pacific coast had not yet been obtained.

Because of an expanded leveling program, more than 10,000 km of new leveling were completed by 1903, including the releveling of some previously unsatisfactory lines. A second adjustment was made, including approximately 6,900 control points in a network of 31,789 km.

In 1907 another 6,500 km of new work had been completed, including the transcontinental leveling through Wyoming, Utah, Idaho, Oregon, and Washington to connect with the tide gage at Seattle, Wash. To utilize the new data the adjustment of 1907 was made. At that time, the network included a total of 38,359 km of leveling and about 9,100 control points. As a matter of expediency, the elevations of most points in the eastern United States were not changed.

New connections to mean sea level on the Gulf coast and the Pacific coast, totaling 9100 km, became available in 1912, including a line across the southern United States from Louisiana to San Diego, Calif., and a north-south line. For the fourth general adjustment of the network, mean sea level was fixed at five tide gages on the Atlantic coast, two on the Gulf coast, and two on the Pacific coast. Orthometric corrections were applied to leveling data in the western States. The 1912 network included 46,462 km of leveling and 11,100 control points.

General Adjustment of 1929. After the previous period of comparatively short intervals between adjustments, 17 years elapsed before the network was adjusted again. In the meantime, it had become more extensive and complex, and included many more sea-level connections. The General Adjustment of 1929 incorporated 75,159 km of leveling in the United States and, for the first

time, 31,565 km of leveling in Canada. The U.S. and Canadian networks were connected by 24 ties between Calais, Me./Brunswick, New Brunswick; and Blaine, Wash./Colebrook, British Columbia. A fixed elevation of zero was assigned to the points on mean sea level determined at the following 26 tide stations:

| | |
|--------------------------------|---------------------------------|
| Father Point, Quebec | St Augustine, Fla |
| Halifax, Nova Scotia | Cedar Keys, Fla |
| Yarmouth, Nova Scotia | Pensacola, Fla |
| Portland, Me | Biloxi, Miss |
| Boston, Mass | Galveston, Tex |
| Perth Amboy, N J. ¹ | San Diego, Calif |
| Atlantic City, N J | San Pedro, Calif |
| Baltimore, Md | San Francisco, Calif |
| Annapolis, Md | Fort Stevens, Ore |
| Old Point Comfort, Va | Seattle, Wash |
| Norfolk, Va | Anacortes, Wash |
| Brunswick, Ga | Vancouver, British Columbia |
| Fernandina, Fla | Prince Rupert, British Columbia |

¹ There was no tide station at Perth Amboy, but the elevation of a bench mark at Perth Amboy was established by leveling from the tide station at Sandy Hook

The 1929 adjustment provided the basis for the definition of elevations throughout the national network as it existed in 1929, and the resulting datum is still used today. The elevations were referred to the "Sea Level Datum of 1929" until 1973, when the more appropriate name "National Geodetic Vertical Datum of 1929" (NGVD29) was adopted for the same reference surface.

The modern network. Since 1929, more than 625,000 km of leveling throughout the United States have been added to the national network. New results have been adjusted to fit into the network of 1929. If both old and new levelings were of similar accuracy and if the Earth's

crust were perfectly stable, this procedure could have continued indefinitely. However, instrumental and procedural improvements make possible a higher degree of accuracy in modern leveling, and, increasingly, the national network has come to play an important role in monitoring crustal movements.

In many regions, withdrawal of underground fluids has led to land subsidence at the surface, which has resulted in significant economic losses. In tectonically active areas earthquakes cause sudden changes in elevation. Elevations are not fixed in time, and, therefore, elevation differences observed at widely different times cannot be expected to agree exactly. Leveling results must be adjusted by epoch and then compared to assess topographic change.

These considerations have led to the establishment of local programs in which regions of known crustal motion have been relevelled periodically to assess the rate and extent of subsidence or uplift. To relate these surveys adequately and to determine where additional work is necessary, the national network itself must be resurveyed at regular intervals.

At present, a minimum network of 100,000 km has been targeted for releveling. This network, known as basic net A (fig. 1-3), is designed to satisfy the standards established by the Federal Geodetic Control Committee for first-order vertical networks (table 1-1).

Vertical control surveys (projects) are conducted continually by field parties of the National Geodetic Survey (NGS) to maintain and update the national network. The procedures by which such projects are accomplished—reconnaissance and bench mark setting, geodetic leveling, river crossing, and data processing—are the subjects of the remaining chapters of this manual.

Table 1-1.—Classification of vertical control networks

| | First order class I | First order class II | Second order class I | Second order class II | Third order |
|--|---|-------------------------|--------------------------|---|--|
| Principle use | Basic net A | | Area control | | Local control |
| Line spacing, | | | | | |
| National net | 100-300 km (60-190 mi) | 50-100 km (30-60 mi) | 20-50 km (10-30 mi) | 10-25 km (5-15 mi) | As needed |
| Metropolitan net | 2-8 km (1-5 mi) | 2-8 km (1-5 mi) | 0.5-1 km (0.3-0.6 mi) | As needed | As needed |
| Maximum length of leveling line between junctions | 300 km (190 mi) | 100 km (60 mi) | 50 km (30 mi) | 50 km (30 mi) double run, 25 km (15 mi) single run | 25 km (15 mi) double run, 10 km (5 mi) single run |
| Control point spacing | Average 1.6 km (1.0 mi), maximum 3 km (2 mi) | | Maximum 3 km (2 mi) | | |

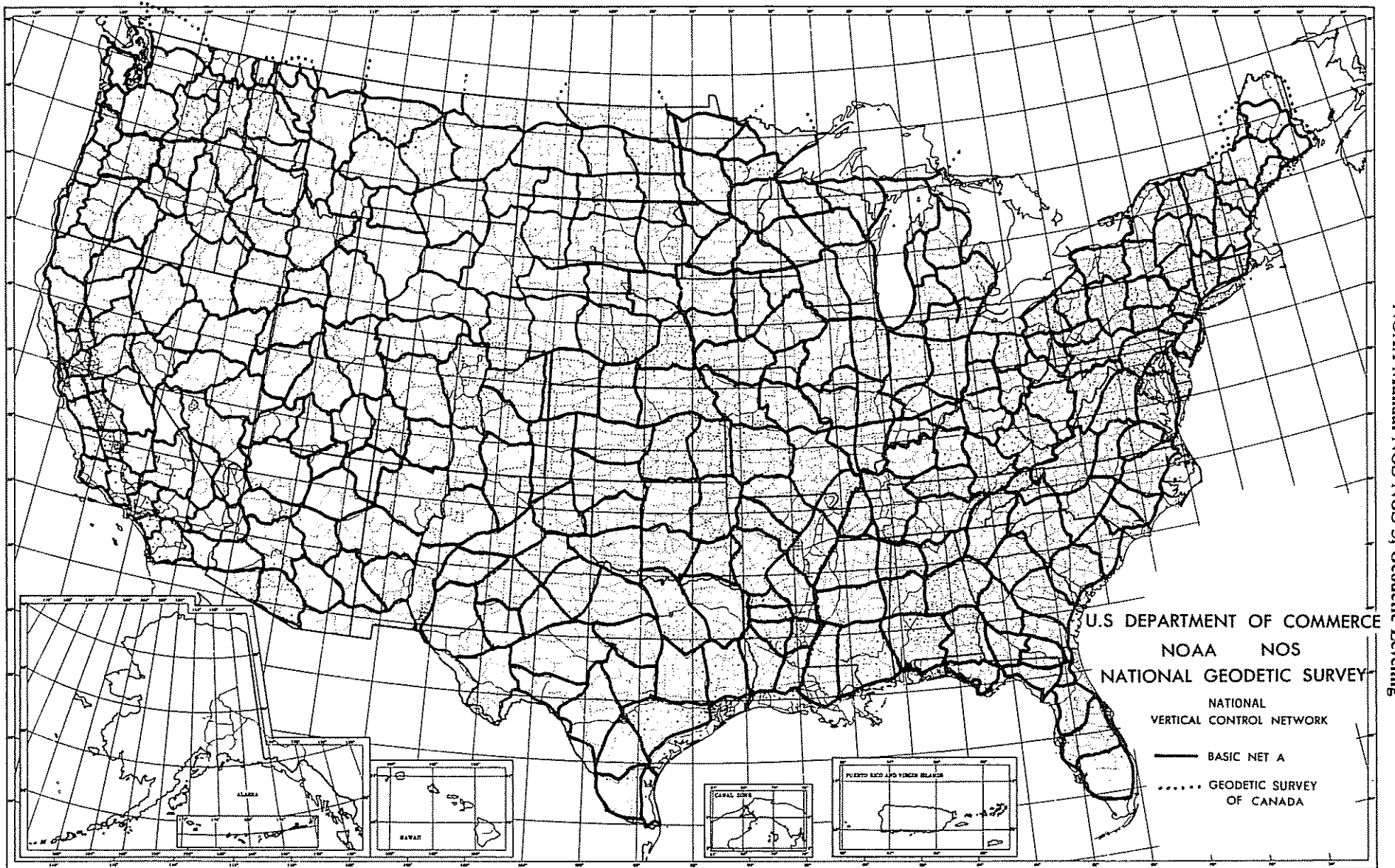

Figure 1-3.—Basic net A of the National Geodetic Vertical Network.

Chapter 2

RECONNAISSANCE AND BENCH MARK SETTING

2.1 Introduction

Before leveling proceeds in a network of vertical control, lines of control points must be defined. This is best accomplished by making a reconnaissance and setting the necessary bench marks a month or more before leveling begins. Detailed instructions for reconnaissance and mark setting are presented in this chapter.

The task is normally performed by personnel organized into mark setting units. Leveling routes are planned in detail to satisfy network requirements. Maps with written instructions (referred to as "logs") are prepared to illustrate the routes for the leveling units. Monuments are recovered, established, and described to mark permanently the lines of vertical control.

Sometimes a single monument must be removed and set elsewhere by a mark maintenance engineer or local surveyor before it is destroyed by highway construction or other activity. The chapter concludes with instructions for relocating such control points.

2.2 Organizing a Mark Setting Unit

At the start of a project, the mark setting personnel should be organized into units and each unit should be assigned a line to reconnoiter and prepare for leveling. Since a typical project encompasses a large area, each unit must be capable of working self-sufficiently, often several hundred kilometers from the project office. This section presents guidelines for organizing and maintaining such units.

2.2.1 Personnel

A foreman should be assigned to supervise the mark setting units and to manage their activities, particularly when many units are operating. Two persons are normally required on each mark setting unit, a mark setter and an assistant.

Mark setting foreman. The mark setting foreman coordinates, supports, and monitors the mark setting units. The foreman's skills should include technical competence in both mark setting and leveling, as well as proficiency in organizing unit activities and maintaining good relations with local agencies and the public. The foreman should set an example which ensures correct, safe, and efficient mark setting.

The foreman is responsible for coordinating the mark setting effort on all the lines in a project. From a study of the preliminary data, he or she should specify routes for each line and determine areas requiring special

attention so that data can be organized and distributed to the appropriate units. Efforts of a specialized unit, such as a drilling-rig team, should be smoothly merged with those of the unit responsible for the line.

The foreman supports the units by providing liaison, training, and supplies. He or she should establish initial contacts with local agencies, and informs the mark setting units if follow-up contacts are necessary. Throughout the project, the foreman should provide technical guidance and training, and, in addition, inventory supplies regularly and place orders to meet future needs.

The foreman should ensure that the specifications and guidelines stated in this manual and in *NOAA Manual NOS NGS 1, Geodetic bench marks* (Floyd 1978), hereinafter referred to as the mark setting manual, are strictly followed. A monthly inspection should be made of each unit. Equipment should be examined to ensure that it is properly maintained. Mark setting techniques should be checked to ensure that safe and correct procedures are followed by the units. After receiving descriptions and logs from a unit, the foreman should routinely inspect the line, looking for poorly set marks, plotting mistakes, and description mistakes. The unit should be made aware of any deficiencies and should correct them immediately. Whenever there is substantial confusion or doubt about a route or mark setting procedure, the project director should be consulted.

The foreman should prepare a report of activities for the project director each month.

Often, if a project is small or the number of available personnel is limited, the foreman may be required to serve as chief of a mark setting unit or leveling unit. When this occurs, the project director should assume most of the responsibilities of the foreman.

Mark setter. As head of a mark setting unit, this individual is normally responsible for the correct reconnaissance and mark setting of an entire line. In addition, he or she must properly maintain and protect a large and varied selection of mechanical equipment. The mark setter who is in charge of a drilling rig has additional maintenance responsibilities. Training and experience in reconnaissance and mark setting as well as strong mechanical ability are necessary qualifications. Leveling experience is highly desirable.

The mark setter should follow the instructions stated in this manual and in the mark setting manual. The project instructions and preliminary data provided by the project director or foreman should be studied and understood. The mark setter should not hesitate to seek guidance when questions arise.

The mark setter should establish an organized work routine with the assistant, incorporating safety precautions into every procedure. Equipment failures should be reported promptly to the foreman or project director. The mark setter should submit monthly reports to the project office.

Assistant mark setter. The assistant mark setter is often a new employee or a member of a leveling unit who is receiving training. The assistant helps the mark setter in all phases of the work, in addition to being assigned certain routine responsibilities, such as truck maintenance and checking control point descriptions.

2.2.2 Equipment

Each unit should be assigned a truck, tools, and other equipment (as itemized in appendix A). When the equipment is issued, the mark setter should conduct an inventory and repeat it at least once every year thereafter. All equipment should be secured in an organized fashion in the assigned vehicle.

The mark setter is responsible for maintaining the truck and tools in good condition. In addition, he or she should study and use the equipment manuals. Equipment losses, damage, or defects should be reported immediately to the foreman or project director. Replacements and repairs should be noted on the monthly report.

Drilling rigs and gasoline-powered portable drills require especially rigorous maintenance if they are to function properly. They should be assigned only to responsible individuals who have demonstrated competence in operating such equipment.

2.2.3 Safety

Mark setting presents numerous situations where personal injury may occur. For this reason, a mark setting unit should always include two persons. All mark setters and assistants should be trained in basic first aid and cardiopulmonary resuscitation. They should know the location and telephone number of an emergency treatment center in the work area, so prompt assistance can be obtained if an accident occurs.

Accidents usually result from hazards created by the environment or the equipment. Anticipate potentially hazardous situations and be prepared to handle them.

The mark setting environment is normally the right-of-way of a highway or railroad. Obtain permission to work in these zones and find out from local officials what safety procedures are required. When working alongside a highway, stay well off the road, wear orange vests, and turn on the truck's warning light. If necessary, and only after consulting with local authorities, use traffic cones, warning signs, or flagmen to divert traffic while setting a mark. When working along a railroad, do not wear orange vests or use flashing lights because these may cause a train to stop unnecessarily. Cross the tracks only at designated crossings; otherwise keep clear of them.

Right-of-way zones are often used as routes for utility pipelines and cables. Select sites for marks with this in mind. Before using an auger or driving a rod, check the site with a pipe and cable locator. Similarly, be alert to the presence of wires *above* the work location, especially when maneuvering a drilling rig or erecting lengths of steel rod.

Mark setting equipment may present a hazard if used improperly. Learn the correct techniques for handling and operating all equipment. Use the right tools for the job and keep them clean. To prevent back injury, lift heavy tools and supplies from a squatting position; use the leg muscles, not the back. Get help if an object is too heavy to lift safely. Above all, stay alert. Do not allow a steady routine to make you complacent.

Two items of equipment deserve special mention: the gasoline-powered rock drill and the drilling rig. When driving rods or drilling with these tools, prevent eye injury by wearing goggles or shatter-proof glasses. Prevent hearing loss by wearing ear plugs or mufflers. Wear hard hats and steel-toed boots.

Mark setters operating a drilling rig must be thoroughly trained in the proper routines for starting and stopping the drill, leveling and stabilizing the truck, and assembling and disassembling the augers. These instructions are outlined in the maintenance manual accompanying the rig. Test the emergency stopping system each day. While drilling, do not wear gloves near the turning augers.

2.2.4 Reports

The project director or foreman should visit each mark setting unit at least once each month. At all other times the mark setters should maintain regular communication, either in person or by telephone, with the project director. In addition, the mark setter should submit the reports described in the following paragraphs.

Monthly report. Mail or submit in person, a report to the project office at the end of work each month. (See fig 2-1.) If work involved more than one State or project, prepare a separate report for each activity. The report is normally forwarded to the headquarters of the National Geodetic Survey, where it provides statistical information about the progress of mark setting in the national network. Include the following information:

1. Number of points recovered in good condition.
2. Number of points recovered in poor condition.
3. Number of points recovered destroyed.
4. Number of points not recovered.
5. Number of bench marks set; types of bench marks set.
6. Notes about condition of equipment and maintenance needed or performed.
7. Inventory of existing supplies.
8. Notes on project activities.

Maintain the report each day, recording the number of points searched for or set and a general statement about the day's activities. As appropriate, include remarks about weather, equipment malfunction, equipment repair, geological conditions, and suggestions. Be sure to list names, telephone numbers, and addresses of officials and individuals who were contacted.

At the end of the month, summarize progress along the assigned lines by totaling the distance of line reconnoitered and prepared for leveling, the number of 7.5 position plots prepared (a 15' plot counts as four), and the number of descriptions written. Do not count plots or descriptions that are not yet finished. Also, inventory specialized mark setting supplies, so their usage can be assessed and future stocks can be procured. List any supplies needed.

Truck report. Keep careful records of all expenses incurred for fuel, oil, repair, and maintenance of mark setting vehicles. At the end of the month, submit a report to the project office summarizing these expenses and include the receipts.

Miscellaneous reports. Be familiar with current organizational procedures for submitting per diem vouchers, accident reports, personnel reports, and expense receipts.

2.3 Routing a Line for Leveling

The reconnaissance and mark setting effort begins with the detailed planning of the leveling routes. The foreman (or project director) should organize and consolidate the preliminary data for a project into packages corresponding to each line or group of lines. A general reconnaissance of the area should be made and liaison should be established with local agencies. The mark setting units then proceed to route each line according to the specifications given in this section, recovering and establishing control points and preparing instructions for the leveling units.

2.3.1 Preliminary Data

For each line or group of lines in a project, a mark setting unit should possess the data listed in table 2-1.

Figure 2-2 shows the areas covered by some of these items. Most of the items are forwarded to the project director along with project instructions. Some items must be obtained in the field. Instructions pertaining to their use are described in the following paragraphs.

Project instructions. Project instructions are the starting point for any survey. They include information and instructions specific to the project which supplement the standard operating procedures given in this manual. Before beginning work, read the instructions thoroughly and consult them whenever in doubt about the project requirements.

Table 2-1.—Preliminary data for reconnaissance and mark setting

| Requirements |
|--|
| Project instructions: |
| Maps for planning and organization: |
| NGS State index map for control leveling |
| NGS Geodetic Control Diagrams |
| USGS State index to topographic maps |
| State and county highway maps |
| Geological and soil maps, as available |
| Descriptions of control points: |
| NGS vertical control data, including a separate listing of archival cross-reference numbers if necessary |
| NGS horizontal control data |
| NGS unpublished descriptions for points recently leveled or reset |
| NOS tide and water-level station reports |
| Descriptions of specially requested points |
| Maps for logs and position plots: |
| USGS topographic maps |
| City and county street maps, as necessary |

Refer to the project instructions to obtain the following information:

1. A rough sketch of the proposed leveling routes.
2. Line numbers and titles.
3. Accession numbers ("L-numbers") of previous survey lines that coincide or connect with the proposed routes.
4. Specific control points to be leveled.
5. Survey-point serial numbers to be assigned to the points in each line.

A table similar to that in figure 2-3 is normally included in the project instructions.

Maps for planning and organization. Several types of maps, covering large parts or all of the project area, are useful for planning and monitoring progress along each line. These maps are most useful if the project lines have been highlighted and labeled in advance.

The Index Map of Control Leveling (fig. 2-4) for the State in which the project is located is available from NGS. It provides an overview of the project area, showing existing first- and second-order lines of leveling. On the index map are plotted and labeled the 30' quadrants into which vertical control data are grouped.

Geodetic Control Diagrams (fig. 2-5) are also available from NGS. They are plots of existing geodetic control at a scale of 1:250,000 on the 1" by 2" quadrangle series of the U.S. Geological Survey (USGS). Control for Alaska is plotted at a scale of 1:500,000 on sectional aeronautical charts. Diagrams are designated by name, number, and two-letter area code. They show the locations of both vertical and horizontal control points and the boundaries of 30' quadrants, 15' topographic maps, and counties. The diagrams are particularly useful when planning connections between leveling lines and other types of control networks. An index of control diagrams for the United States is given in appendix B.

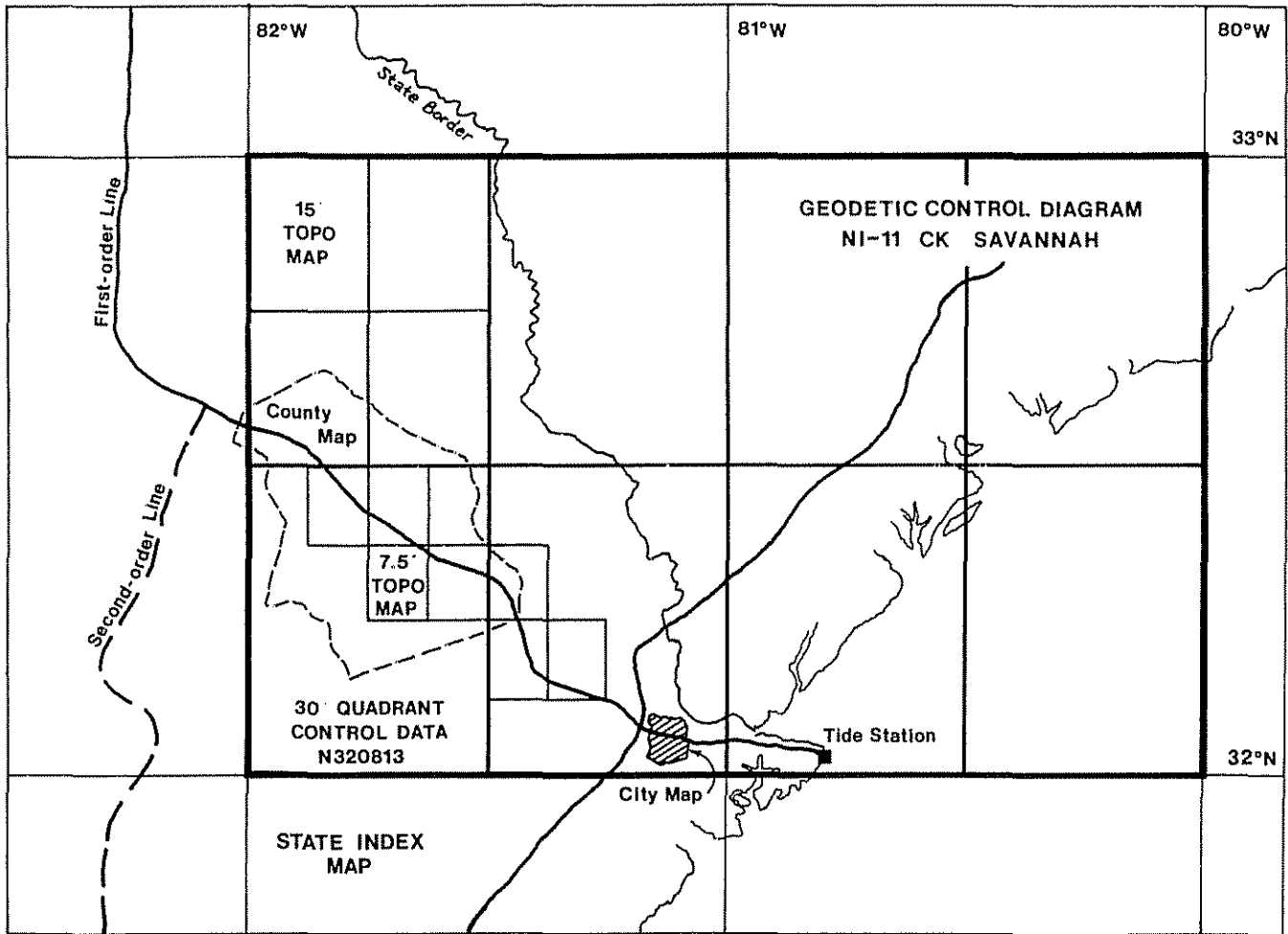

Figure 2-2.—Scale relationships of preliminary data.

TABLE 1

| *JC* | LINE NO. | PROJECT TITLE/LINE TITLE |
|------|----------|---|
| *W2* | | HARRIS-GALVESTON COASTAL SUBSIDENCE AREA TX |
| *W2* | 1 | ADDICKS VIA HOUSTON TO CROSBY |
| *W2* | 2 | ADDICKS VIA BELLAIRE TO HOUSTON |
| *W2* | 3 | HOUSTON VIA LEAGUE CITY TO GALVESTON - PIER 21 TIDE STATION |
| *W2* | 4 | CROSBY VIA BAYTOWN AND TEXAS CITY TO LA MARQUE |
| *W2* | 5 | 3 KM W QF PASADENA TO LA PORTE |
| *W2* | 6 | WEBSTER TO SEABROOK |

TABLE 2

| *JC* | LINE NO. | LENGTH KM. | OLD HGZ NO. | USE SPSN'S |
|------|----------|------------|-------------------|------------|
| *W2* | 1 | 80 | L24406-12,-19,-25 | 1-200 |
| *W2* | 2 | 60 | L24406-10,-11 | 201-300 |
| *W2* | 3 | 80 | L24406-7,-2 | 301-500 |
| *W2* | 4 | 100 | L24406-19,-20,-4 | 501-700 |
| *W2* | 5 | 30 | L24406-21,-22 | 701-800 |
| *W2* | 6 | 10 | L24406-6 | 801-900 |

Figure 2-3.—Example of line assignments in project instructions.

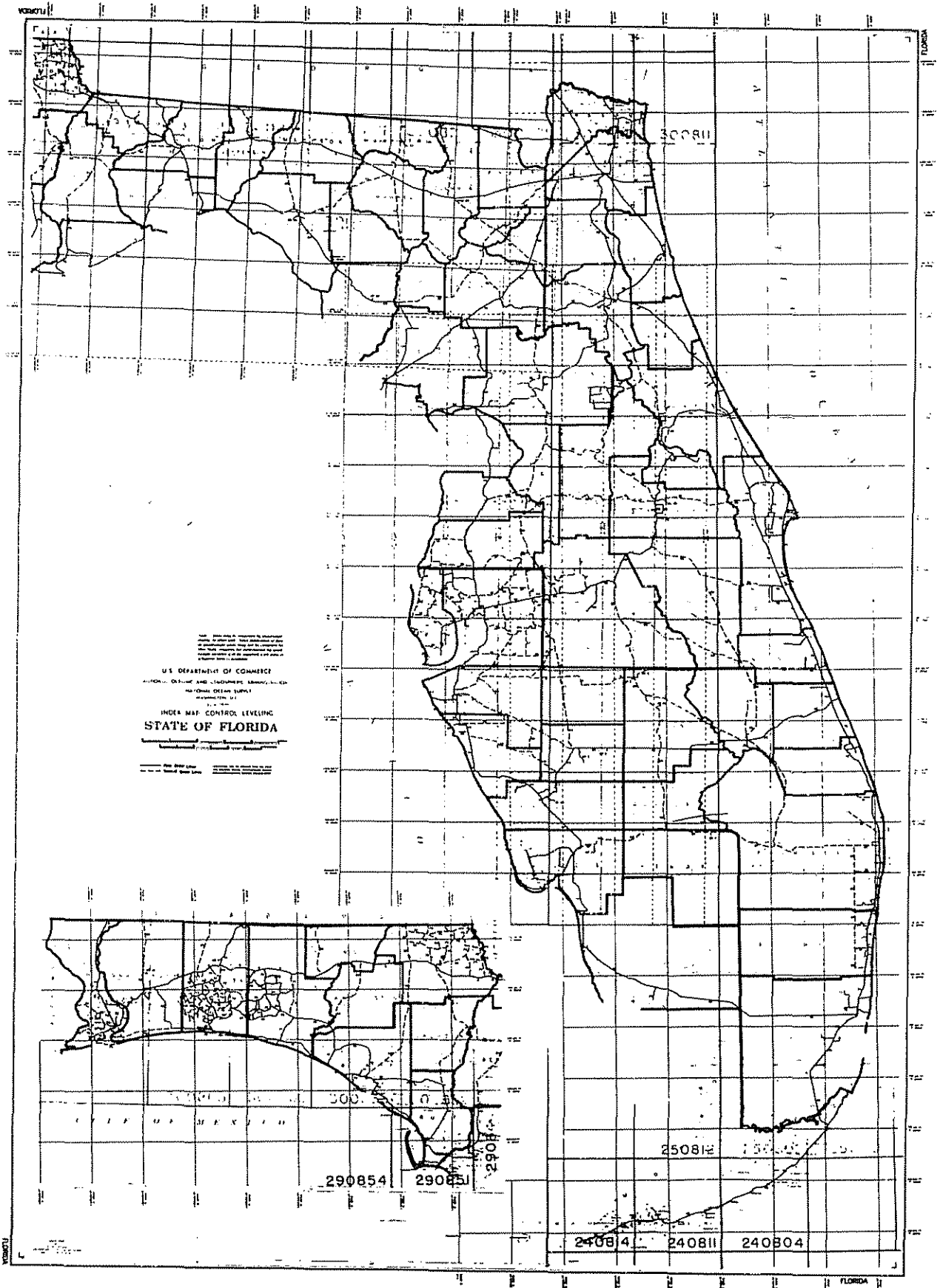

Figure 2-4.—State Index Map of Control Leveling.

The Index to Topographic Maps for the State in which the project is located is available from USGS. Although the index does not show all geographical features, the project lines may be plotted approximately (fig. 2-6). It is extremely useful as an index and check-off list for logs and smooth plots.

State and county highway maps are usually available from district offices of a State highway or State transportation department. Since topographic maps do not always show the latest highway construction and route numbers, current State highway maps should be the final source for this information.

Consult geological and soil maps when selecting sites for bench marks. Basic information about the location and type of expansive soils throughout the United States is provided in the mark setting manual. Additional information, especially for locating bedrock and fault zones, can be obtained from geological maps published by the USGS or State agencies, such as departments of mines and natural resources. Information concerning soil types and depths is often available from local offices of the U.S. Soil Conservation Service.

Other sources that may be useful for certain projects include aeronautical charts, storm evacuation maps, and nautical charts. These are available from the National Ocean Survey (NOS).

Descriptions of control points. To recover existing vertical and other control points, published descriptions should be consulted. Because they serve different purposes, descriptions for vertical control, horizontal control, and tide or water-level stations are prepared, stored, and published separately.

Vertical Control Data, available from NGS, are published in sets. Each set ("quad" or "litho list") includes data for all the vertical control points in a 30' quadrant. The quadrant is identified by hemisphere, latitude, longitude, and quarter. After the hemisphere symbol, "N" or "S", a 1° by 1° area is identified by the degrees of latitude bounding it on the south (on the north in the southern hemisphere) and by the degrees of longitude bounding it on the east. The quadrants are numbered clockwise within the 1° by 1° area, beginning with the northeast: "1" signifies the northeast quarter, "2" the southeast, "3" the southwest, and "4" the northwest.

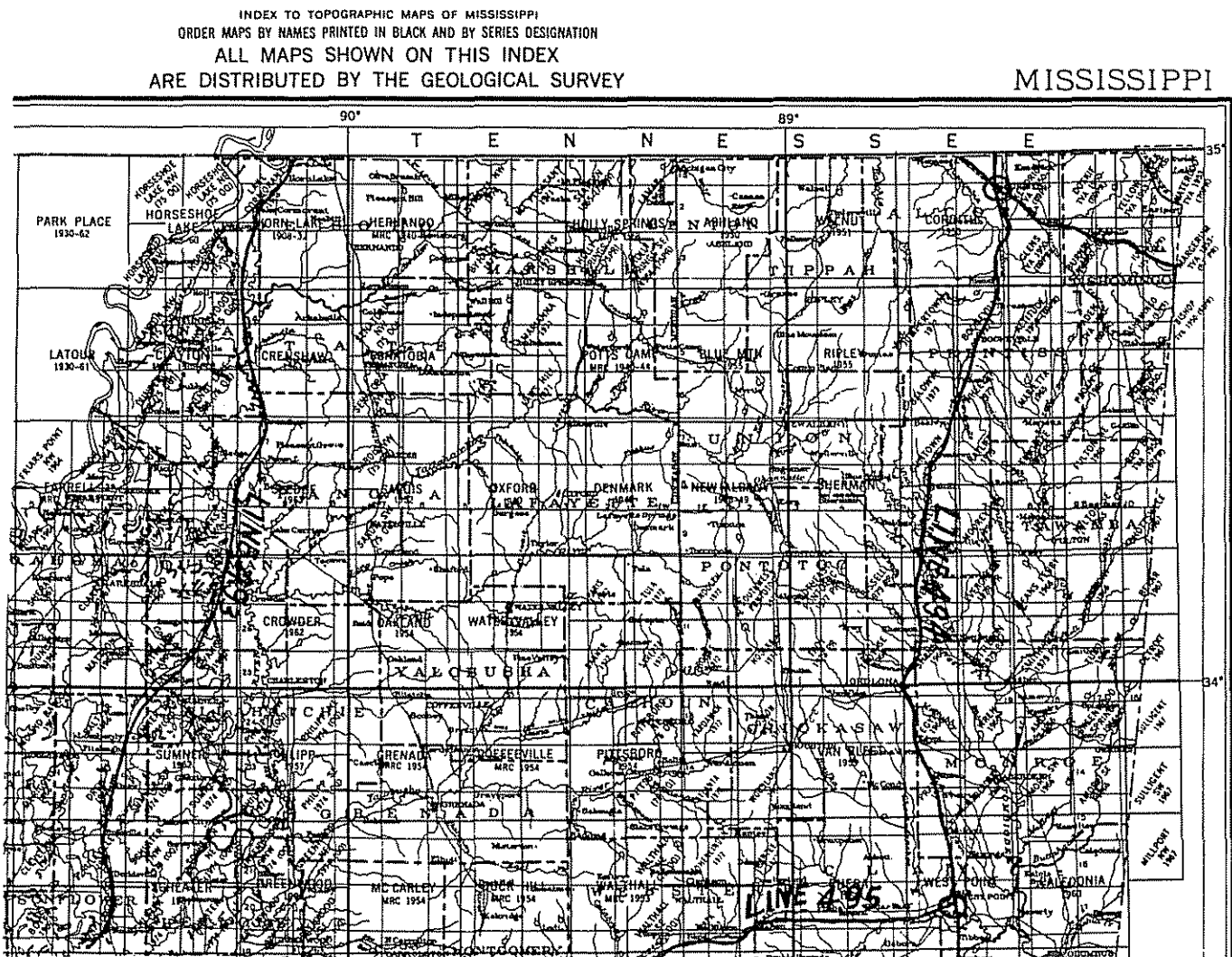

Figure 2-6.—Index to Topographic Maps, project lines plotted.

For example, "N340901" signifies a 30' quadrant which is the northeast quarter of the 1° by 1° area bounded by 34° N on the south and 090° W on the east.

Each quadrant includes a plot showing the lines of control points described within the quad (fig. 2-7a). The line numbers given in the plot are unique only within the quadrant; they do not necessarily correspond to those of adjacent quadrants. Arrows indicate the order in which control points are described along each line. The plot is followed by two indexes that give the designations of points in alphanumeric order (fig. 2-7b) and line order (fig. 2-7c). Descriptions and other data (fig. 2-7d) are then given in line order.

Each control point is assigned a unique number (the archival cross-reference number) when it is initially included in the NGS data base. If the published descriptions do not include these numbers, obtain special listings of the synoptic file ("archive lists") from the NGS Vertical Network Division. Identified by two-letter area codes, these listings are available for each Geodetic Control Diagram (See fig. 2-8a,b.)

Data for horizontal control points are also available in 30' quadrants from NGS. Descriptions are usually arranged chronologically within each quadrant. An alphanumeric index of designations is included. After finding the designation of the desired point on a Geodetic Control Diagram, look it up in the appropriate index to find the page number of the description. Further information about horizontal control data is available in *NOAA Technical Memorandum NOS NGS 5, National Geodetic Survey data: availability, explanation, and application* (Dracup 1979).

For up-to-date information on points that have recently been recovered, established, or relocated, obtain descriptions from the NGS Vertical Network Division. It is possible that these data may not yet be included in the published descriptions. File the recent descriptions with the appropriate 30' quadrant, and remember to use them. A reset mark may be mistaken for the original one if the mark setter is unaware of the complete history of the control point.

Descriptions for tide and water-level stations are available from the NOS Tides and Water Levels Division. Each station is identified by a unique seven-digit number. The first three digits identify the State or body of water. A list of these codes is shown in table 2-2. Station listings are published in *NOAA Tide Tables: High and Low Water Levels* (National Ocean Survey, annual publication). Request the most recent station reports for all tide and water-level stations in a project area. Station reports include the name, address, and telephone number of the station observer, bench mark descriptions, and a sketch of the station showing bench mark locations.

Leveling to specific control points may be specially requested either in the project instructions or by local agencies. The points may include junction points, international boundary monuments, airport monuments,

compaction meters, deep-well casings, and monuments of USGS, State highway departments, counties, and cities. If the necessary descriptions are not provided with project instructions, the descriptions should be obtained from the appropriate agency.

Maps for position plots and logs. Positions of all points recovered or established must be plotted on the standard 7.5 series of topographic maps available from USGS. If 7.5 maps are not available, the 15' series should be used. Because plots are difficult to see on orthophotographic maps, maps of this type should not be used.

The U.S. Geological Survey may be revising or compiling new 7.5 maps for the project area. Check with USGS and request State progress maps, available from the USGS regional topographic division. Up-to-date 7.5 "bluelines," which are preliminary compilations of topographic maps, can then be ordered.

In major metropolitan areas, logs should be prepared on up-to-date city or county street maps, available from the Chamber of Commerce, the city government, or local gasoline stations. However, plots must still be made on 7.5 maps to ensure consistent and accurate scaling of positions.

2.3.2 Liaison

While routing the leveling line, a mark setting unit must communicate frequently with the owners, managers, and users of both public and private property. The purpose of these contacts is to obtain permission and make detailed arrangements for both mark setters and leveling units to work in the areas necessary for completion of the project. In addition, a systematic liaison effort may bring to light unusual environmental conditions or ongoing projects of other agencies which affect the choice of leveling routes. Maintaining good public relations is vital to the project.

The project director lays the groundwork for future cooperation and coordination by notifying the appropriate State highway or transportation department in advance of the project. The project director should send a letter requesting permission to operate in the right-of-way zones of the necessary State highways, plus a courtesy copy of the project instructions. If routes include railroad right-of-way zones, follow a similar procedure. The project instructions may list other agencies or individuals to contact.

Immediately after arrival in the project area, the mark setting foreman should visit officials of the agencies with which liaison is necessary. To set bench marks of the best possible quality, visit agencies and individuals who may provide maps or other specific information about the geology along the proposed routes. Determine if surveys exist that should be connected to the national network and inform the appropriate mark setting units. In addition, make arrangements to obtain sufficient supplies during the project.

U. S. DEPARTMENT OF COMMERCE
 NATIONAL OCEANIC AND ATMOSPHERIC ADMINISTRATION
 NATIONAL OCEAN SURVEY

VERTICAL CONTROL DATA
 BY THE
 NATIONAL GEODETIC SURVEY
 NATIONAL GEODETIC VERTICAL DATUM OF 1929

QUAD 340901
 STATE AR-MS-TH
 LATITUDE 34° 30' TO 35° 0'
 LONGITUDE 90° 0' TO 90° 30'
 DIAGRAM HELENA NI 15-6

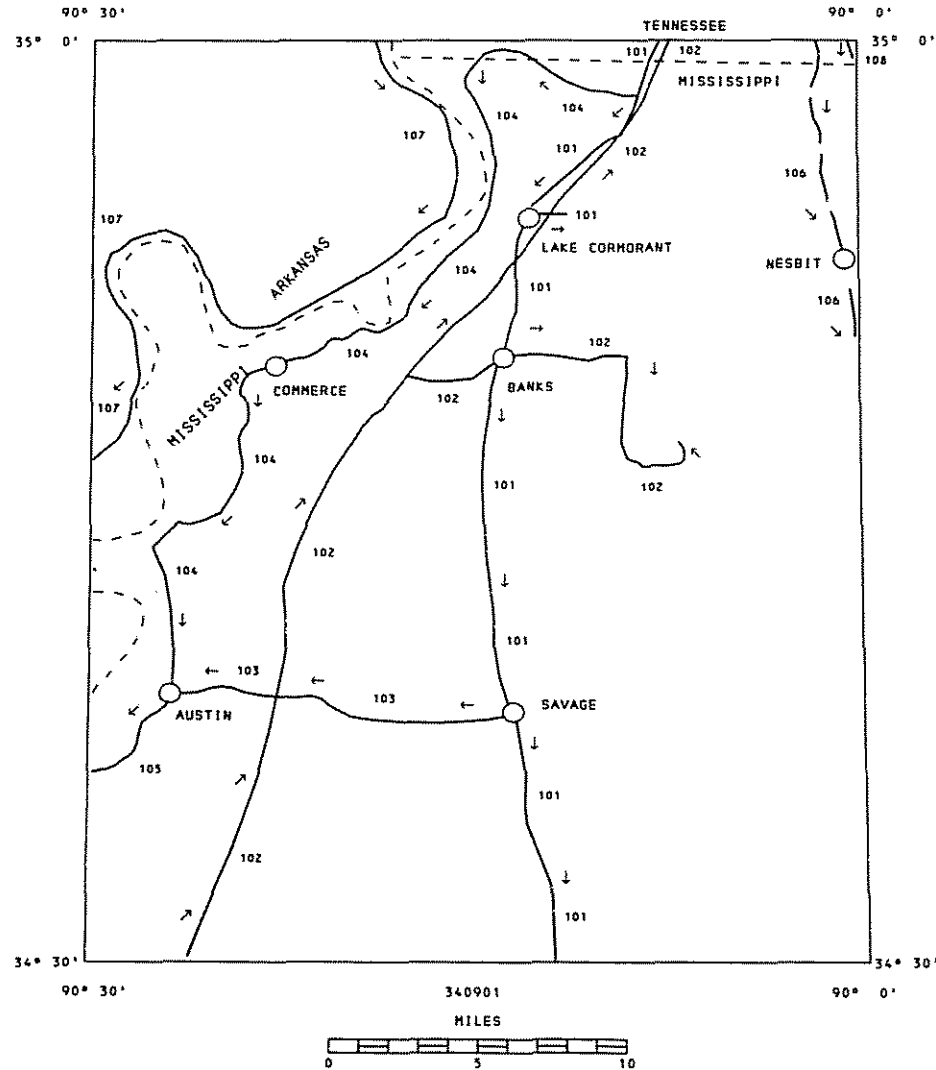

Figure 2-7a.—Index plot for 30' quadrant of Vertical Control Data.

US DEPARTMENT OF COMMERCE - NOAA
 NOS - NATIONAL GEODETIC SURVEY
 ROCKVILLE MD 20852 - APR 1980

VERTICAL CONTROL DATA
 NATIONAL GEODETIC VERTICAL DATUM 1929
 ADJUSTED BY--CGS YEAR--1957
 SOURCE--L15801

SEON--051
 QUAD--N34090100 LINE--101
 STATE--MS DIAGRAM--NI 15-6
 COUNTY--TATE

BENCH MARK
 DESIGNATION--V 194

ORDER--1ST MONUMENTATION QUALITY--B APPROX LAT 34-37-47N
 ESTABLISHED BY--CGS YEAR--1956 POSITION--LON 090-13-22W

| | | | | |
|---|----------------------------------|----------------------------|----------------------------------|---|
| H - ELEVATION ABOVE NGVD 1929 (NORMAL ORTHOMETRIC HEIGHT) | MODELED BOUGUER ANOMALY SIGMA | MODELED SURFACE GRAVITY | NORMAL GRAVITY (1967 FORMULA) | NORMAL GEOPOTENTIAL NUMBER (GPU=KILOGALMETER) |
| 58.238 METERS (191.069 FEET) | -7.7 MGALS 0.9 | 979.682 GALS | 979.702 GALS | 57.056 GPUS |

***** BENCH MARK RECOVERY *****
 DESIGNATION--V 194 STATE--MS COUNTY--TATE QUAD--N340901 XRN--EH0051
 ***** MONUMENT BY--CGS ***** YR--1956 COP--UNK MARK TYPE--BENCH MARK DISK *****
 ***** RECOVERY BY--MSHD ***** YR--1966 COP--UNK CONDITION--GOOD *****
 STAMPING--V 194 (1956)
 SETTING--PIER
 LOCATED--0.3 MI SE FROM THE CITY OR TOWN OF--SAVAGE

TO REACH FROM THE U.S. POST OFFICE IN CRENSHAW GO NORTH ON MISSISSIPPI HIGHWAY 3 FOR 7.55 MILES TO
 MISSISSIPPI HIGHWAY 4 ON THE RIGHT. CONTINUE NORTHWEST ON HIGHWAY 3 FOR 2.1 MILES TO THE BRIDGE OVER
 THE RAILROAD TRACK AND THE MARK SET VERTICALLY IN THE SOUTH FACE OF THE CONCRETE BASE OF THE FIRST
 PIER WEST OF THE TRACK. IT IS 35.7 FEET WEST OF THE WEST RAIL OF THE MAIN TRACK AND 22 FEET WEST OF
 THE WEST RAIL OF THE SIDE TRACK.

US DEPARTMENT OF COMMERCE - NOAA
 NOS - NATIONAL GEODETIC SURVEY
 ROCKVILLE MD 20852 - APR 1980

VERTICAL CONTROL DATA
 NATIONAL GEODETIC VERTICAL DATUM 1929
 ADJUSTED BY--CGS YEAR--1957
 SOURCE--L15801

SEON--052
 QUAD--N34090100 LINE--101
 STATE--MS DIAGRAM--NI 15-6
 COUNTY--TATE

BENCH MARK
 DESIGNATION--W 194

ORDER--1ST MONUMENTATION QUALITY--D APPROX LAT 34-36-50N
 ESTABLISHED BY--CGS YEAR--1956 POSITION--LON 090-13-11W

| | | | | |
|---|----------------------------------|----------------------------|----------------------------------|---|
| H - ELEVATION ABOVE NGVD 1929 (NORMAL ORTHOMETRIC HEIGHT) | MODELED BOUGUER ANOMALY SIGMA | MODELED SURFACE GRAVITY | NORMAL GRAVITY (1967 FORMULA) | NORMAL GEOPOTENTIAL NUMBER (GPU=KILOGALMETER) |
| 55.995 METERS (183.710 FEET) | -6.5 MGALS 0.8 | 979.683 GALS | 979.700 GALS | 54.858 GPUS |

***** BENCH MARK RECOVERY *****
 DESIGNATION--W 194 STATE--MS COUNTY--TATE QUAD--N340901 XRN--EH0052
 ***** MONUMENT BY--CGS ***** YR--1956 COP--UNK MARK TYPE--BENCH MARK DISK *****
 ***** RECOVERY BY--MSHD ***** YR--1966 COP--UNK CONDITION--GOOD *****
 STAMPING--W 194 (1956)
 SETTING--SHALLOW-SET PIPE
 LOCATED--1.4 MI SOUTH FROM THE CITY OR TOWN OF--SAVAGE

TO REACH FROM THE U.S. POST OFFICE IN CRENSHAW GO NORTH ON MISSISSIPPI HIGHWAY 3 FOR 7.55 MILES TO
 MISSISSIPPI HIGHWAY 4 ON THE RIGHT. CONTINUE NORTHWEST ON HIGHWAY 3 FOR 1.0 TO A SIDE ROAD LEFT
 RUNNING BETWEEN A GROCERY STORE AND A STORAGE GARAGE, TURN LEFT (WEST) AND CONTINUE ON AN
 ALL-WEATHER ROAD FOR 0.15 MILE TO A TENANT HOUSE ON THE RIGHT. CONTINUE WEST ON A FIELD ROAD FOR
 0.25 MILE TO THE RAILROAD TRACK, TURN LEFT SOUTH AND FOLLOW THE WEST EDGE OF A FIELD FOR 0.35 MILE
 TO THE MARK ON THE RIGHT AS DESCRIBED. IT IS APPROXIMATELY 185 YARDS NORTH OF MILEPOST 41, 110 FEET
 SOUTHWEST OF POLE NO. 725, 57.5 FEET WEST-NORTHWEST OF POLE NO. 725 1/2, 23 FEET WEST OF THE WEST
 RAIL, 4.3 FEET SOUTHEAST OF A TELEPHONE POLE, AND 1.6 FEET SOUTH OF A METAL WITNESS POST.

Figure 2-7b.—Vertical Control Data sheet.

| SEQN | DESIGNATION | YEAR ESTABLISHED | LAST RECOV | ELEVATION ORD (METERS) | SOURCE | APPROXIMATE LATITUDE | POSITION LONGITUDE | SURFACE GRAVITY | OTHER CONTROL | QUAD OSN | ST |
|------|-------------------|------------------|------------|------------------------|--------|----------------------|--------------------|-----------------|---------------|-----------|----|
| 48 | T 117 USE | UNK D | 1966G | 1ST 57.354 | L15801 | 34-38-03N | 90-13-35W | 979.682 | | N34090100 | MS |
| 33 | T 193 | 1956D | 1966G | 1ST 58.406 | L15801 | 34-45-09N | 90-14-38W | 979.686 | | N34090100 | MS |
| 44 | T 194 | 1956D | 1966G | 1ST 56.160 | L15801 | 34-39-26N | 90-14-08W | 979.683 | | N34090100 | MS |
| 66 | T 195 | 1956D | 1966G | 1ST 56.793 | L15801 | 34-30-17N | 90-11-42W | 979.679 | | N34090100 | MS |
| 66 | T' 195 USGS | 1956D | 1966G | 1ST 56.793 | L15801 | 34-30-17N | 90-11-42W | 979.679 | | N34090100 | MS |
| 164 | T 196 | 1956D | 1966G | 1ST 57.771 | L15798 | 34-38-28N | 90-26-22W | 979.687 | | N34090100 | MS |
| 211 | T 218 | 1976B | | 1ST 67.481 | L24103 | 34-51-47N | 90-21-22W | 979.704 | | N34090100 | AR |
| 226 | T 219 | UNK B | 1976G | 1ST 58.989 | L24103 | 34-49-01N | 90-28-24W | 979.709 | | N34090100 | AR |
| 131 | T 238 | 1974C | 1976G | 1ST 61.147 | L23280 | 34-50-24N | 90-16-23W | 979.696 | | N34090100 | MS |
| 126 | T 243 | 1974C | | 1ST 89.054 | L23280 | 34-46-57N | 90-07-08W | 979.681 | | N34090100 | MS |
| 146 | T 260 | 1974C | | 1ST 74.821 | L23280 | 34-59-42N | 90-07-30W | 979.712 | | N34090100 | TN |
| 54 | TBM A STA 146 | 1953D | 1966G | 1ST 57.262 | L15801 | 34-35-56N | 90-13-00W | 979.682 | | N34090100 | MS |
| 54 | TBM A STA 146 USE | 1953D | 1966G | 1ST 57.262 | L15801 | 34-35-56N | 90-13-00W | 979.682 | | N34090100 | MS |
| 55 | TBM B STA 146 | 1953D | 1966G | 1ST 57.319 | L15801 | 34-35-56N | 90-13-01W | 979.682 | | N34090100 | MS |
| 55 | TBM B STA 146 USE | 1953D | 1966G | 1ST 57.319 | L15801 | 34-35-56N | 90-13-01W | 979.682 | | N34090100 | MS |
| 174 | TBM 44/45 | UNK D | 1966N | 1ST 58.574 | L00422 | 34-37-32N | 90-28-08W | 979.684 | | N34090100 | MS |
| 174 | TBM 44/45 USE | UNK D | 1966N | 1ST 58.574 | L00422 | 34-37-32N | 90-28-08W | 979.684 | | N34090100 | MS |
| 183 | TBM 46/47 | UNK D | 1966N | 1ST 57.356 | L00422 | 34-36-02N | 90-29-05W | 979.681 | | N34090100 | MS |
| 183 | TBM 46/47 USE | UNK D | 1966N | 1ST 57.356 | L00422 | 34-36-02N | 90-29-05W | 979.681 | | N34090100 | MS |
| 35 | U 193 | 1956D | 1966G | 1ST 57.642 | L15801 | 34-44-25N | 90-14-36W | 979.686 | | N34090100 | MS |
| 45 | U 194 | 1956D | 1966G | 1ST 55.362 | L15801 | 34-38-40N | 90-14-02W | 979.683 | | N34090100 | MS |
| 65 | U 195 | 1956D | 1966G | 1ST 54.124 | L15801 | 34-31-04N | 90-11-41W | 979.680 | | N34090100 | MS |
| 165 | U 196 | 1956C | 1974G | 1ST 59.402 | L23280 | 34-38-27N | 90-26-57W | 979.686 | | N34090100 | MS |
| 212 | U 218 | 1976B | | 1ST 67.214 | L24103 | 34-51-31N | 90-22-22W | 979.704 | | N34090100 | AR |
| 227 | U 219 | 1976B | | 1ST 66.326 | L24103 | 34-48-19N | 90-28-57W | 979.706 | | N34090100 | AR |
| 132 | U 238 | 1974C | 1976G | 1ST 61.488 | L23280 | 34-50-45N | 90-16-54W | 979.697 | | N34090100 | MS |
| 139 | U 243 | 1974C | | 1ST 61.652 | L23280 | 34-54-41N | 90-11-21W | 979.702 | | N34090100 | MS |
| 1 | U 75 | 1956D | | 1ST 71.125 | L15801 | 34-59-55N | 90-08-06W | 979.714 | | N34090100 | TN |
| 36 | V 193 | 1956D | 1966G | 1ST 58.295 | L15801 | 34-43-29N | 90-14-35W | 979.685 | | N34090100 | MS |
| 51 | V 194 | 1956B | 1966G | 1ST 58.238 | L15801 | 34-37-47N | 90-13-22W | 979.682 | | N34090100 | MS |
| 64 | V 195 | 1956D | 1966G | 1ST 57.061 | L15801 | 34-31-58N | 90-11-41W | 979.680 | | N34090100 | MS |
| 213 | V 218 | 1976B | | 1ST 67.183 | L24103 | 34-51-22N | 90-23-23W | 979.705 | | N34090100 | AR |
| 133 | V 238 | 1974B | 1976G | 1ST 62.172 | L24103 | 34-50-46N | 90-17-48W | 979.698 | | N34090100 | MS |
| 140 | V 243 | 1974C | | 1ST 61.631 | L23280 | 34-55-18N | 90-10-47W | 979.703 | | N34090100 | MS |
| 5 | W 193 | 1956D | 1974N | 1ST 62.927 | L15801 | 34-57-49N | 90-09-01W | 979.710 | | N34090100 | MS |
| 52 | W 194 | 1956D | 1966G | 1ST 55.995 | L15801 | 34-36-50N | 90-13-11W | 979.682 | | N34090100 | MS |
| 62 | W 195 | 1956D | 1966G | 1ST 55.713 | L15801 | 34-32-34N | 90-11-49W | 979.681 | | N34090100 | MS |
| 82 | W 237 | 1974B | | 1ST 57.969 | L23280 | 34-38-26N | 90-22-33W | 979.687 | | N34090100 | MS |
| 135 | W 238 | 1974C | 1976G | 1ST 60.369 | L23280 | 34-51-01N | 90-15-36W | 979.696 | | N34090100 | MS |
| 141 | W 243 | 1974C | | 1ST 64.680 | L23280 | 34-55-51N | 90-09-59W | 979.703 | | N34090100 | MS |

Figure 2-7c.—Alphanumeric indexes for 30' quadrant of Vertical Control Data.

US DEPARTMENT OF COMMERCE - NOAA
 NOS - NATIONAL GEODETIC SURVEY
 ROCKVILLE MD 20852 - APR 1980

LIST OF CONTENTS
 VERTICAL CONTROL DATA
 NATIONAL GEODETIC VERTICAL DATUM 1929

LAT SPAN 34-30.1N TO 34-59.9N
 LON SPAN 90-00.1W TO 90-29.8W
 DIAGRAM--NI 15-6 INDEX PG--02

| SEON | DESIGNATION | YEAR ESTABLISHED | LAST RECOV | ELEVATION ORD (METERS) | SOURCE | APPROXIMATE LATITUDE | POSITION LONGITUDE | SURFACE GRAVITY | OTHER CONTROL | QUAD | QSN | ST |
|------|----------------|------------------|------------|------------------------|--------|----------------------|--------------------|-----------------|---------------|-----------|------|----|
| 41 | E 194 | 1956B | 1966G | 1ST 57.239 | L15801 | 34-41-56N | 90-14-12W | 979.685 | | N34090100 | | MS |
| 42 | R 194 | 1956D | 1966G | 1ST 56.688 | L15801 | 34-41-06N | 90-14-13W | 979.684 | | N34090100 | | MS |
| 43 | S 194 | 1956D | 1966G | 1ST 56.547 | L15801 | 34-40-16N | 90-14-10W | 979.684 | | N34090100 | | MS |
| 44 | T 194 | 1956D | 1966G | 1ST 56.160 | L15801 | 34-39-26N | 90-14-08W | 979.683 | | N34090100 | | MS |
| 45 | U 194 | 1956D | 1966G | 1ST 55.362 | L15801 | 34-38-40N | 90-14-02W | 979.683 | | N34090100 | | MS |
| 46 | 186 | UNK D | 1966X | 1ST 56.668 | 00726 | 34-38-25N | 90-13-51W | 979.683 | | N34090100 | | MS |
| 47 | T 116 | UNK D | 1966G | 1ST 58.793 | L15801 | 34-38-10N | 90-13-38W | 979.682 | | N34090100 | | MS |
| 48 | T 117 | UNK D | 1966G | 1ST 57.354 | L15801 | 34-38-03N | 90-13-35W | 979.682 | | N34090100 | | MS |
| 49 | F 194 | 1956B | 1966G | 1ST 56.599 | L15801 | 34-38-04N | 90-13-32W | 979.682 | | N34090100 | | MS |
| 50 | PTS 30 | 1908D | 1966G | 1ST 56.854 | L15801 | 34-38-01N | 90-13-34W | 979.682 | | N34090100 | | MS |
| 51 | V 194 | 1956B | 1966G | 1ST 58.238 | L15801 | 34-37-47N | 90-13-22W | 979.682 | | N34090100 | | MS |
| 52 | W 194 | 1956D | 1966G | 1ST 55.995 | L15801 | 34-36-50N | 90-13-11W | 979.682 | | N34090100 | | MS |
| 53 | M 194 | 1956D | 1966G | 1ST 56.987 | L15801 | 34-35-59N | 90-13-03W | 979.682 | | N34090100 | | MS |
| 54 | TBM A STA 146 | 1953D | 1966G | 1ST 57.262 | L15801 | 34-35-56N | 90-13-00W | 979.682 | | N34090100 | | MS |
| 55 | TBM B STA 146 | 1953D | 1966G | 1ST 57.319 | L15801 | 34-35-56N | 90-13-01W | 979.682 | | N34090100 | | MS |
| 56 | 183 | UNK C | 1956N | 1ST 55.768 | 00726 | 34-35-39N | 90-12-59W | 979.682 | | N34090100 | | MS |
| 57 | Z 195 | 1956D | 1966G | 1ST 56.316 | L15801 | 34-35-00N | 90-12-51W | 979.682 | | N34090100 | | MS |
| 58 | Y 195 | 1956D | 1966G | 1ST 56.819 | L15801 | 34-34-43N | 90-12-49W | 979.682 | | N34090100 | | MS |
| 59 | P-14-13 | 1940D | 1966G | 1ST 61.029 | L15801 | 34-34-08N | 90-12-30W | 979.681 | | N34090100 | | MS |
| 60 | H 194 | 1954B | 1966G | 1ST 60.886 | L15801 | 34-34-09N | 90-12-30W | 979.681 | | N34090100 | | MS |
| 61 | X 195 | 1956D | 1966G | 1ST 56.696 | L15801 | 34-33-28N | 90-12-10W | 979.681 | | N34090100 | | MS |
| 62 | W 195 | 1956D | 1966G | 1ST 55.713 | L15801 | 34-32-34N | 90-11-49W | 979.681 | | N34090100 | | MS |
| 63 | PTS 32 | UNK D | 1966X | 1ST 55.306 | 00726 | 34-32-09N | 90-11-42W | 979.680 | | N34090100 | | MS |
| 64 | V 195 | 1956D | 1966G | 1ST 57.061 | L15801 | 34-31-58N | 90-11-41W | 979.680 | | N34090100 | | MS |
| 65 | U 195 | 1956D | 1966G | 1ST 54.124 | L15801 | 34-31-04N | 90-11-41W | 979.680 | | N34090100 | | MS |
| 66 | T 195 | 1956D | 1966G | 1ST 56.793 | L15801 | 34-30-17N | 90-11-42W | 979.679 | | N34090100 | | MS |
| 67 | S 195 | 1956D | 1966G | 1ST 56.381 | L15801 | 34-30-11N | 90-11-51W | 979.679 | | N34090100 | | MS |
| 68 | PTS 33 | 1908D | 1967G | 1ST 56.891 | L15801 | 34-30-10N | 90-11-39W | 979.679 | | N34090100 | | MS |
| 69 | CONCRETE MON 2 | UNK D | 1956N | 1ST 57.619 | 00726 | 34-30-07N | 90-11-47W | 979.679 | | N34090100 | | MS |
| 70 | H 245 | 1974B | | 1ST 54.296 | L23280 | 34-30-30N | 90-25-53W | 979.677 | | N34090100 | | MS |
| 71 | C 245 | 1974D | | 1ST 54.362 | L23280 | 34-31-33N | 90-25-30W | 979.679 | | N34090100 | | MS |
| 72 | D 245 | 1974C | | 1ST 55.091 | L23280 | 34-32-22N | 90-25-13W | 979.680 | | N34090100 | | MS |
| 73 | F 245 | 1974C | | 1ST 56.735 | L23280 | 34-33-13N | 90-24-54W | 979.681 | | N34090100 | | MS |
| 74 | G 245 | 1974D | | 1ST 55.160 | L23280 | 34-34-13N | 90-24-32W | 979.683 | | N34090100 | | MS |
| 75 | J 245 | 1974B | | 1ST 56.363 | L23280 | 34-34-59N | 90-24-15W | 979.683 | | N34090100 | | MS |
| 76 | CLAYTON RM 1 | 1956C | 1974G | 1ST 58.021 | L23280 | 34-35-56N | 90-23-53W | 979.684 | | N34090100 | | MS |
| 77 | CLAYTON | 1967C | 1974G | 1ST 57.727 | L23280 | 34-35-51N | 90-23-55W | 979.684 | H | N34090133 | 0002 | MS |
| 78 | CLAYTON RM 2 | 1956C | 1974G | 1ST 57.790 | L23280 | 34-35-56N | 90-23-55W | 979.684 | | N34090100 | | MS |
| 79 | CLAYTON AZ | 1956C | 1974G | 1ST 57.555 | L23280 | 34-36-18N | 90-23-46W | 979.685 | | N34090100 | | MS |
| 80 | K 245 | 1974C | | 1ST 57.281 | L23280 | 34-37-10N | 90-23-27W | 979.686 | | N34090100 | | MS |

Figure 2-7d.—Line order index for 30' quadrant.

| DESIGNATION | ACRN # | POSITION |
|-------------------|--------|-----------|
| A 10 | BG0922 | 0300864 |
| A 10 AZ MK | BG0921 | 0300864 |
| A 10 BM | BG0524 | 0300864 |
| A 10 RM 1 | BG0923 | 0300864 |
| A 10 RM 2 | BG0924 | 0300864 |
| A 11 | BG2640 | 0300874 |
| A 113 | BG0222 | 0300871 |
| A 115 | BG0097 | 0300871 |
| A 124 | BG1001 | 0300864 |
| A 125 | BG1035 | 0300864 |
| A 136 | BG1036 | 0300864 |
| A 137 | BG2035 | 0300863 |
| A 138 | BG1115 | 0300864 |
| A 139 | BG1636 | 0300861 |
| A 140 | BG1458 | 0300861 |
| A 141 | BG1434 | 0300861 |
| A 156 | BG0907 | 0300864 |
| A 158 | BG0002 | 0300871 |
| A 16 RM 1 A VITRO | BG1021 | 0300864 |
| A 16 RM 1 B VITRO | BG1022 | 0300864 |
| A 16 RM 2 A VITRO | BG1019 | 0300864 |
| A 16 RM 2 B VITRO | BG1020 | 0300864 |
| A 16 VITRO | BG1018 | 0300864 |
| A 161 | BG1817 | 0300872 |
| A 162 | BG0042 | 0300871 |
| A 163 | BG1706 | 0300872 |
| A 163 RESET 1964 | BG1707 | 0300872 |
| A 165 | BG0257 | 0300871 |
| A 168 | BG0498 | 0300864 |
| A 169 | BG2615 | 0300864 |
| A 178 | BG2255 | 0300802 |
| A 179 | BG2073 | 0300863 |
| A 180 | BG2081 | 0300863 |
| A 181 | BG1466 | 0300861 |
| A 182 | BG0207 | 0300862 |
| A 182 RESET 1962 | BG2275 | 0300862 |
| A 25 | BG1711 | 0300872 |
| A 26 | BG1772 | 0300872 |
| A 27 | BG2156 | 0300862 |
| A 28 | BG0800 | 0300864 |
| A 29 | BG1120 | 0300864 |
| A 297 | BG1974 | 0300863 |
| A 299 | BG1921 | 0300863 |
| A 302 | BG0137 | 0300871 |
| A 303 | BG0125 | 0300871 |
| A 380 | BG3435 | 030087123 |
| A 395 | BG3462 | 030086341 |
| A 409 | BG2644 | 0300874 |
| A 436 | BG2495 | 0300874 |
| A 437 | BG2528 | 0300874 |
| A 84 | BG0025 | 0300871 |
| A 85 | BG0387 | 0300864 |

Figure 2-8a.—Listing of synoptic file.

| ACRN # | DESIGNATION | POSITION |
|--------|-------------------|----------|
| BG0001 | I 8 | 0300871 |
| BG0002 | A 158 | 0300871 |
| BG0003 | B 158 | 0300871 |
| BG0004 | J 8 | 0300871 |
| BG0005 | C 158 | 0300871 |
| BG0006 | K 8 | 0300871 |
| BG0007 | D 158 | 0300871 |
| BG0008 | E 158 | 0300871 |
| BG0009 | L 8 | 0300871 |
| BG0010 | F 158 | 0300871 |
| BG0011 | G 158 | 0300871 |
| BG0012 | M 8 | 0300871 |
| BG0013 | H 158 | 0300871 |
| BG0014 | N 8 | 0300871 |
| BG0015 | K 158 | 0300871 |
| BG0016 | J 158 | 0300871 |
| BG0017 | O 8 | 0300871 |
| BG0018 | L 158 | 0300871 |
| BG0019 | P 8 | 0300871 |
| BG0020 | M 158 | 0300871 |
| BG0021 | N 158 | 0300871 |
| BG0022 | Q 8 | 0300871 |
| BG0023 | P 158 | 0300871 |
| BG0024 | Q 158 | 0300871 |
| BG0025 | A 84 | 0300871 |
| BG0026 | B 84 RESET 1939 | 0300871 |
| BG0027 | B 84 | 0300871 |
| BG0028 | C 84 RESET 1939 | 0300871 |
| BG0029 | C 84 | 0300871 |
| BG0030 | D 84 | 0300871 |
| BG0031 | D 84 RESET 1939 | 0300871 |
| BG0032 | E 84 RESET 1939 | 0300871 |
| BG0033 | E 84 | 0300871 |
| BG0034 | F 84 | 0300871 |
| BG0035 | G 84 | 0300871 |
| BG0036 | H 84 | 0300871 |
| BG0037 | J 84 | 0300871 |
| BG0038 | K 84 | 0300871 |
| BG0039 | L 84 | 0300871 |
| BG0040 | R 158 | 0300871 |
| BG0041 | S 158 | 0300871 |
| BG0042 | A 162 | 0300871 |
| BG0043 | B 162 | 0300871 |
| BG0044 | T 8 | 0300871 |
| BG0045 | C 162 | 0300871 |
| BG0046 | U 8 | 0300871 |
| BG0047 | D 162 | 0300871 |
| BG0048 | QUINTETTE AZ MK | 0300871 |
| BG0049 | QUINTETTE 2 AZ MK | 0300871 |
| BG0050 | QUINTETTE RM 1 | 0300871 |
| BG0051 | QUINTETTE RM A | 0300871 |
| BG0052 | QUINTETTE RM 2 | 0300871 |
| BG0053 | E 162 | 0300871 |

Figure 2-8b.—Listing of synoptic file.

Table 2-2.—Location codes for tide and water-level stations

| States | Codes | States | Codes |
|---------------------------|-------|---------------------|-------|
| Alabama (AL) | 873 | Montana (MT) | 931 |
| Alaska (AK) | 945 | Nebraska (NE) | 924 |
| Arizona (AZ) | 938 | Nevada (NV) | 936 |
| Arkansas (AR) | 881 | New Hampshire (NH) | 842 |
| California (CA) | 941 | New Jersey (NJ) | 853 |
| Colorado (CO) | 934 | New Mexico (NM) | 937 |
| Connecticut (CT) | 846 | New York (NY) | 851 |
| Delaware (DE) | 855 | North Carolina (NC) | 865 |
| District of Columbia (DC) | 859 | North Dakota (ND) | 922 |
| Florida (FL) | 872 | Ohio (OH) | 892 |
| Georgia (GA) | 867 | Oklahoma (OK) | 927 |
| Hawaii (HI) | 161 | Oregon (OR) | 943 |
| Idaho (ID) | 932 | Pennsylvania (PA) | 854 |
| Illinois (IL) | 896 | Rhode Island (RI) | 845 |
| Indiana (IN) | 895 | South Carolina (SC) | 866 |
| Iowa (IA) | 912 | South Dakota (SD) | 923 |
| Kansas (KS) | 925 | Tennessee (TN) | 882 |
| Kentucky (KY) | 883 | Texas (TX) | 877 |
| Louisiana (LA) | 876 | Utah (UT) | 935 |
| Maine (ME) | 841 | Vermont (VT) | 843 |
| Maryland (MD) | 857 | Virginia (VA) | 863 |
| Massachusetts (MA) | 844 | Washington (WA) | 944 |
| Michigan (MI) | 901 | West Virginia (WV) | 864 |
| Minnesota (MN) | 911 | Wisconsin (WI) | 902 |
| Mississippi (MS) | 874 | Wyoming (WY) | 933 |
| Missouri (MO) | 884 | United States | 83x |

| Channels | Codes | Lakes | Codes |
|-------------------|----------|-------------------|----------|
| St Lawrence River | 831-1xxx | Lake Champlain | 843-1xxx |
| Niagara River | 906-3xxx | Lake Ontario | 905-2xxx |
| Detroit River | 904-4xxx | Lake Erie | 906-3xxx |
| St Clair River | 901-4xxx | Lake St Clair | 903-4xxx |
| Saginaw River | 901-xxxx | Lake Huron | 907-5xxx |
| Grand River | 908-xxxx | Lake Michigan | 908-7xxx |
| Chicago River | 896-1111 | Lake Winebago | 902-02xx |
| Fox River | 902-01xx | Lake Superior | 909-9xxx |
| Milwaukee River | 902-03xx | Rainy Lake | 911-01xx |
| St Marys River | 907-6xxx | Lake of the Woods | 911-09xx |
| Rainy River | 911-05xx | | |

A mark setting unit should also contact officials of the local highway districts, county and city transportation departments, Indian reservations, and other public and private agencies as required when traversing their property. Ask district officials about current and proposed highway widening projects. Enlist their assistance to avoid the effects of such projects when routing the line. Learn the construction details of culverts and bridges, and the locations of bedrock. Often, local officials can point out or specify existing monuments that will be destroyed, assist in recovery work, and recommend suitable locations for new bench marks.

Since highway right-of-way zones are often occupied by gas, water, or sewer pipelines, and electric or telephone cables, determine the location of such utilities before installing a monument. Look for signs marking

pipelines or cables and obtain the assistance of a representative from the local servicing office if a rod must be driven near a pipe or cable.

Although most vertical control points are located on public land, occasional points may require that a private property owner or manager be approached as well. Sometimes, in addition to the owner's permission, special information must be obtained, such as the age and construction details of a building or the presence of active irrigation wells adjacent to a proposed monument site. When ownership cannot be readily determined, consult the county Recorder of Deeds. Never search for or establish a control point without first obtaining the property owner's permission.

When requesting permission from property owners to use their property, give them a fact sheet that de-

scribes the purpose of the survey. The fact sheet should also explain how the monument will be constructed and the importance of the monument to the vertical control network. An example is shown in figure 2-9. Always

behave in a respectful and tactful manner and obey the homeowners' wishes concerning the use of their property.

Maintain a record of each contact made, including the designations of the relevant control points and the



UNITED STATES DEPARTMENT OF COMMERCE
National Oceanic and Atmospheric Administration
 NATIONAL OCEAN SURVEY
 Rockville Md 20852

NATIONAL GEODETIC SURVEY - INFORMATION NOTICE

The National Geodetic Survey (NGS), an office of the National Ocean Survey, NOAA, Department of Commerce, will be conducting a Geodetic Survey in your area in the near future. In preparation for this work, NGS field units are now installing survey points, known as bench marks, at intervals of approximately one mile along major highways and other thoroughfares. These bench marks will be tied to the national network of thousands of similar points throughout the United States which form the framework for a precise network of vertical control stations (points of precisely known elevations). This survey work is undertaken at the request of Federal, state, and local agencies for use in such projects as mapping, resource management, flood control, crustal motion studies (geodynamics), space exploration and large-scale engineering projects.

At selected locations throughout the country, special high quality bench marks are being established as part of a seven-year program to redefine the entire national geodetic vertical control network. These marks often take the form of brass disks cemented into bedrock outcrops or large buildings. Where this kind of mark is not feasible, a special truck-mounted drill is used to install a sleeved rod bench mark (as described in Figure 1.) Due to the stringent accuracy requirements placed on the elevations of these bench marks, particular care is taken when they are established. The mark must be well constructed, unlikely to be disturbed, and accessible to the general public.

Because of the above considerations, selection of an acceptable site is crucial. Thus, it is often necessary to rely on the public spirit of land owners for permission to establish survey stations on private property. It is the policy of the National Geodetic Survey to install bench marks only upon the informed consent of the property owners. An NGS bench mark can provide a valuable public service, and enhance property values by serving as a reference for any surveying done in the immediate area.

Once it is installed the elevation is precisely determined by a National Geodetic Survey vertical control party. This elevation is then published along with the description of the physical location of the bench mark and its position (latitude and longitude). The bench mark then takes its place in the national network as a basic reference point for a variety of surveying, mapping, planning, engineering and scientific applications.

Enclosure



Figure 2-9a.—Form letter distributed to property owners.

NATIONAL GEODETIC SURVEY VERTICAL CONTROL MARKER

In 1978 the National Geodetic Survey (NGS) introduced a new, improved bench mark into the National Vertical Control Network. The reference point for the elevation is the top of a stainless steel rod. The rod is located inside a protective aluminum casement that bears the NGS logo and the stamped bench mark designation. Users can obtain access to the rod by lifting a hinged access cover.

The bench mark is designed to prevent near-surface soil movements, e.g., frost heave, shrinkage, swelling, from disturbing the mark. This is accomplished by encasing the rod in a lubricated sleeve to the depth of

expected soil movement and by anchoring the rod in the soil below.

Top and side views of the bench mark are depicted below. Additional information about this mark can be obtained by writing to the Director, National Geodetic Survey, National Ocean Survey, NOAA, Rockville, Md. 20852.

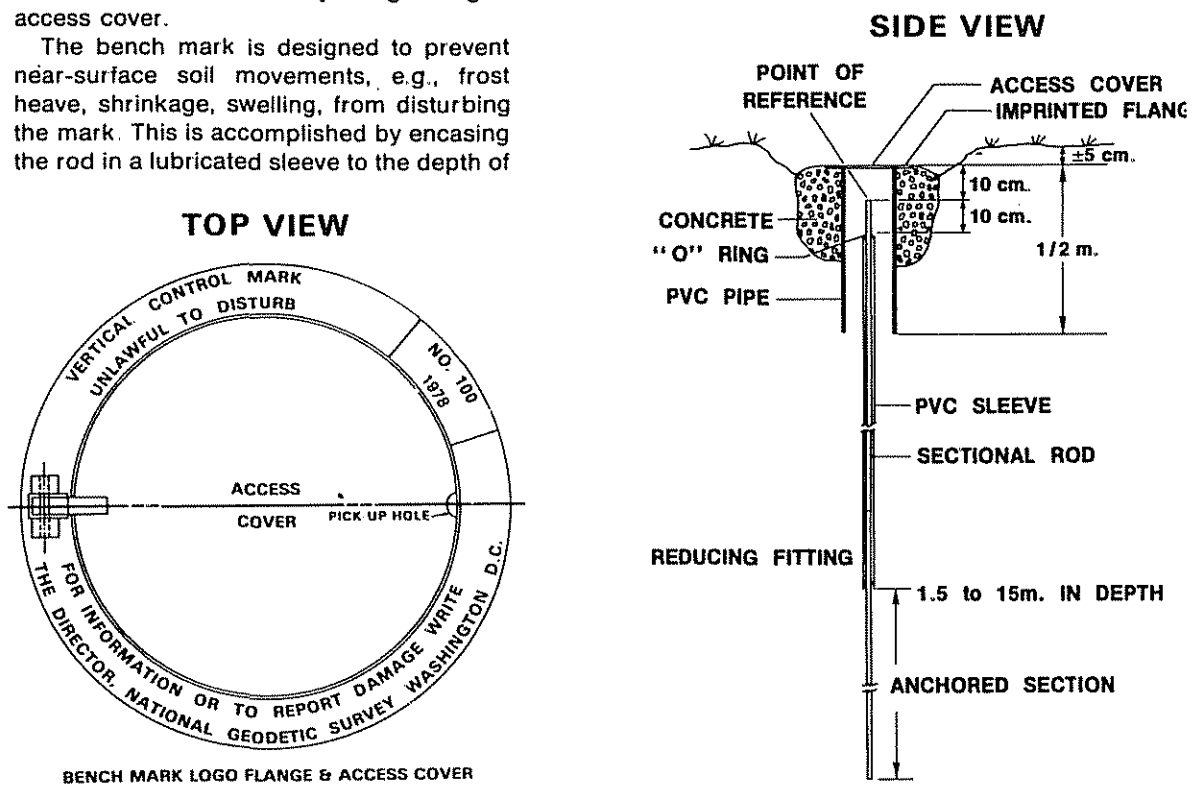

U.S. DEPARTMENT OF COMMERCE
National Oceanic and Atmospheric Administration
National Ocean Survey

Figure 2-9b.—Form letter distributed to property owners.

name, address, and telephone number of the individual contacted. Upon completion of the project, this record is used to send published descriptions of the points to

private owners and public managers as a courtesy. Requests for survey results and elevation data should be referred to the National Geodetic Information Center.

2.3.3 Routing Specifications

The actual routes to be followed by the lines of a geodetic leveling project depend primarily on the purpose of the project, as do the types and spacing of control points along each route. Given in this section are routing specifications appropriate to lines of the National Geodetic Vertical Network.

Junctions. Lines in a network begin and end at clusters of control points called junctions. In a large network, considerable time (sometimes several years) may elapse between the completion of one line and the start of another; therefore, the monuments at junctions must be permanent and stable. The most desirable locations for junctions are areas without significant subsidence or uplift relative to a majority of the area covered by the network. Though cities often serve as the logical intersections for lines routed along highways, cities may not be the best locations for junctions. Locate a junction in the most stable zone possible, even if it is necessary to detour as much as 10 km (6 mi) from the logical intersection of the lines. (See the examples in fig. 2-10.)

To establish the junction, recover or set three control points of the best possible quality. Locate them at intervals of at least 0.5 km (0.3 mi). This limits the possibility that they might all be affected by the same local disturbance. At an international boundary, locate the points along the border, if possible, so they are accessible to surveyors from either country. All three points must be leveled in every line beginning or ending at the junction.

At the end of the field season or project, if the leveling along a line must stop at some location short of the ending junction, the location should be chosen carefully and monumented with three control points of the best possible quality, as described in the previous paragraph. These are not strictly considered to be junction points, but they should be releveled for a tie when the line is resumed.

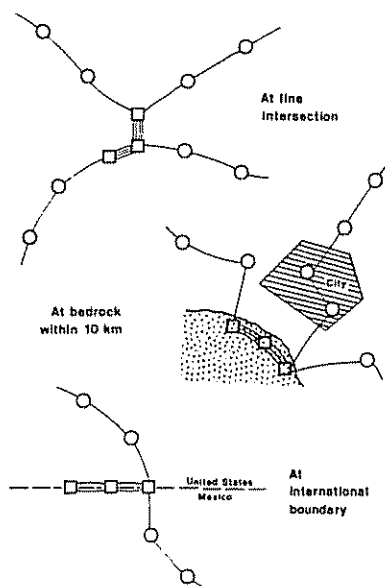

Figure 2-10.—Network junctions.

Routes. The mark setter must weigh many factors when routing the line. Paramount among these are the permanence, stability, and accessibility of the control points. Choose a route which permits the greatest proportion of control points to meet these standards. Since the lines of the national network are, for the most part, already in place, routing typically involves recovering or relocating an existing line.

In the past, lines of leveling usually followed railroad right-of-way zones, which often provided the only negotiable path through undeveloped areas. Today, these zones are not always accessible or convenient to the person who will be using local vertical control. The improvements in mark setting and leveling efficiency made possible by the use of vehicles depend on greater accessibility. Therefore, whenever a railroad does not have a continuous access road available to both public and private surveyors within five leveling setups (at the most 0.5 km or 0.3 mi), relocate the line to the edge of a highway right-of-way zone which parallels the railroad. Special connections should be made to the existing line. (See sec. 2.3.4, "Previous surveys.")

In the vicinity of an interstate highway or other controlled access roads, whenever possible, route the line so it is accessible from parallel roads outside the right-of-way fence. Avoid routing the line along the proposed route of a new highway, but if this is unavoidable, route the line as close as possible to the edges of the proposed right-of-way zones.

Leveling experience is helpful when selecting a route across rough terrain or through congested urban areas. Unlike a control point for triangulation, a control point for leveling must be readily accessible by land from the points that exist before and after it in the line. Avoid routing the line through short, extreme changes in elevation, such as down gullies or up and over embankments. When a monument must be set in such an inconvenient location to ensure permanence and stability, note the most efficient leveling route on the log.

If an obstacle is encountered that cannot be crossed by ordinary leveling—such as a river, bay, mudflat, marsh, or deep ravine—a "river crossing" technique may be required. This procedure may also be required if a bridge cannot be leveled across, either because it is subject to intense vibration or because traffic cannot be stopped for the length of time necessary. See sec. 4.2.1 for selecting and preparing river crossing sites.

Spurs. Portions of line that branch to control points not in the main line are called spurs. Spurs end on points not otherwise connected to the network, unless they are routed to make connections with previous surveys. Avoid creating spurs of less than 1.0 km (0.6 mi). Control points located closer than 1.0 km should be leveled as part of the line.

If routing a new line along an existing line that includes spurs, the spurs may be excluded unless they provide access to control points of unusually high quality or they are specified for inclusion by the project instructions.

Control points. The spacing between control points in the national network should average 1.6 km (1.0 mi). In dense networks, designed to measure such phenomena as movement near faults or local subsidence, spacing should average 1.0 km (0.6 mi) or less.

The distance between any pair of control points may normally range between 1.0 and 3.0 km (0.6 and 1.9 mi). In municipalities, housing or commercial zones, and other areas of intensive development, shorten the spacing to 1.0 km. In rural areas, with gentle terrain and only infrequent periods of windy or stormy weather, spacing may be increased.

If a portion of the line must follow a steep grade, space the control points to limit the number of leveling setups required to 40 or less. If the steep grade extends over several kilometers or the entire line, adopt an average spacing which corresponds to the slope. Estimate the slope (elevation difference divided by distance) from a topographic map and consult table 2-3 for a suitable spacing.

Control points should be marked with monuments of the best expected quality. However, new monuments of the best quality may be the most expensive and time-consuming to set. Furthermore, existing monuments of lower expected quality historically have often performed well and should not be removed from the line unless they are in unsatisfactory condition. Consequently, best-quality monuments need not be installed at every control point. Unless project instructions specify otherwise, recover or set a monument of the best possible quality at the following locations (fig. 2-11):

1. At network junctions, including international boundaries (set three monuments).
2. At one or both ends of a portion of line not to be leveled to both junctions during one field season (set three).
3. At the base of a spur or spurs connecting a previous survey that intersects the line (set one).

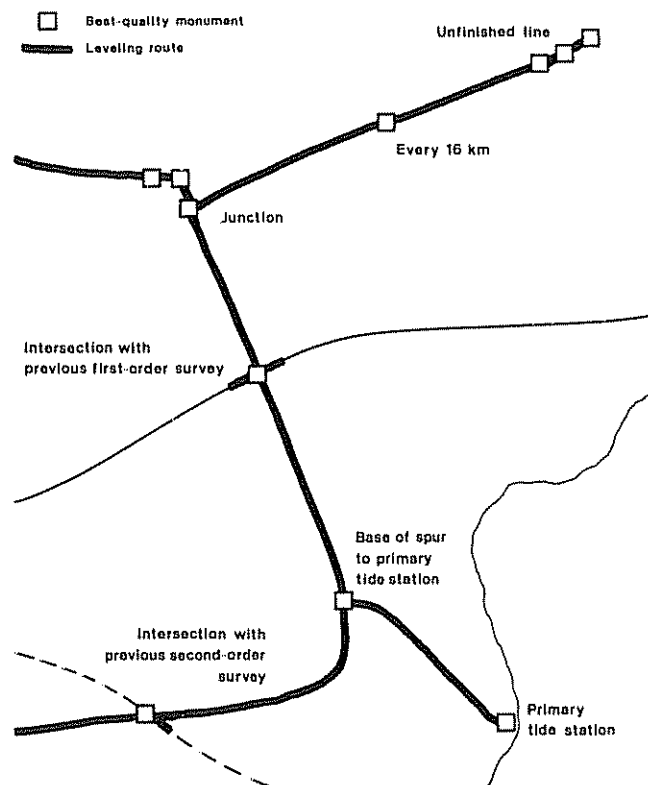

Figure 2-11.—Locations for monuments of the best possible quality.

4. At the base of a spur connecting a primary tide station (set one).
5. At a primary tide station (set one).
6. At least every 16 km (10 mi) along the line (set one).

2.3.4 Connections

To provide a common frame of reference in which elevations may be computed, two or more ties should be established between the line or lines of every level-

Table 2-3.—Spacing control points along slopes

This table is based on a change in elevation of 2 m (6 ft) during each setup, the normal maximum when following the specifications for geodetic leveling given in chapter 3.

| Slope (percent) | Maximum leveling sighting distance m (ft) | Maximum distance between control points km (mi) | Recommended average spacing km (mi) |
|-----------------|---|---|-------------------------------------|
| 1 | Maximum tolerance | 3.0 (1.9) | 1.6 (1.0) |
| 2 | 50 (164) | 3.0 (1.9) | 1.6 (1.0) |
| 3 | 33 (108) | 2.7 (1.7) | 1.1 (0.7) |
| 4 | 25 (82) | 2.0 (1.2) | 0.8 (0.5) |
| 5 | 20 (66) | 1.6 (1.0) | 0.6 (0.4) |
| 6 | 16 (52) | 1.3 (0.8) | 0.5 (0.3) |
| 8 | 12 (39) | 1.0 (0.6) | 0.4 (0.25) |
| 10 | 10 (33) | 0.8 (0.5) | 0.3 (0.2) |
| 15 | 6 (20) | 0.5 (0.3) | 0.2 (0.1) |
| 30 | 3 (10) | 0.3 (0.2) | 0.1 (0.05) |

ing project and the National Geodetic Vertical Network. A tie consists of two or more control points that, after they have been leveled and checked, connect a line to a previous survey.

When routing the lines of a project, connecting points must be recovered to permit ties to be made that span the area of the project. To the extent that they serve the purpose of the project, connections should also be routed to other types of control networks. Given next are specifications for connections to be made when routing lines of the national network. The requirements are summarized in table 2-4.

Previous surveys When lines of a previous survey are releveled or intersected as part of a project, the ties established permit the previous survey to be readjusted and brought up-to-date with the current work.

If all or part of an existing line is to be releveled, route it by recovering the control points as they are described in the vertical control data. If the existing route is no longer accessible (as is the case with many lines following railroads) and the line must be relocated, recover the points of the best quality and include them in the new, parallel route. If possible, include such points at the following intervals along the line: 5 km (3 mi) if the distance separating the new and old routes is less than 0.5 km (0.3 mi), 10 km (6 mi) if the separation is between 0.5 and 2.0 km (0.3 and 1.2 mi), and 20 km (12 mi) if the separation is greater than 2.0 km (1.2 mi). (See fig. 2-12.)

Make a connection whenever the route intersects a line of a previous survey. If both current and previous surveys are of first-order precision, recover at least three control points that were leveled during the previous survey. Connect them with a spur (or spurs), recover-

ing or setting a monument of the best possible quality at or near the point where the spur joins the main line (fig. 2-13). All three points must be leveled to establish a tie. If either or both of the surveys are of less than first-order precision, recover at least two control points for the connection.

Often "area surveys" are encountered, where two or more lines of a previous survey are intersected. In this case, make connections by recovering at least one control point from the previous survey at each intersection (fig. 2-14). At least three such points, spanning the area of the survey, must be leveled to establish a tie.

A local survey of good quality that has not previously been included in the national network may be connected by following these procedures. Consult the appropriate local officials to obtain descriptions of monuments that might serve as connecting points.

Do not extend a spur more than 8 km (5 mi) to make a connection to a previous survey, unless special project instructions apply.

Tide and water-level stations. Connections between the national network and primary tide stations are essential to compare and relate elevations to the sea-level surface at various points along the coasts of the United States. Similarly, connections to water-level stations permit elevations to be obtained for the mean lake level at various points along the shores of the Great Lakes. Project instructions should provide a list of tide and water-level stations to be connected.

Numerous secondary and tertiary tide and water-level stations may be located near a line routed along a shore. Unless project instructions specify otherwise, connect these only if they are no more than 4 km (2.5 mi) from the line.

Table 2-4.—Requirements for connections

| Connection | Spacing | Minimum number of connecting points |
|---|--|-------------------------------------|
| <i>Previous surveys:</i> | | |
| Parallel, 0.5 km (0.3 mi) or less away | Every 5 km (3 mi) | 1 |
| Parallel, 0.5 to 2.0 km (0.3 to 1.2 mi) away | Every 10 km (6 mi) | 1 |
| Parallel, more than 2.0 km (1.2 mi) away | Every 20 km (12 mi) | 1 |
| Intersected, first-order line | At every intersection | 3 |
| Intersected, second-order line | At every intersection | 2 |
| Intersected, area survey | At two intersections that span the area | 3 |
| <i>Tide and water-level stations:</i> | | |
| Primary | At every station | 5 |
| Secondary | At stations less than 4 km (2.5 mi) away | 3 |
| Tertiary | At stations less than 4 km (2.5 mi) away | 3 |
| Active airports | At airports not leveled before and less than 4 km (2.5 mi) away | 1 |
| Gravity stations | At every station | 1 |
| Horizontal control and three-dimensional stations | At stations not leveled before and less than 4 km (2.5 mi) away | 1 |

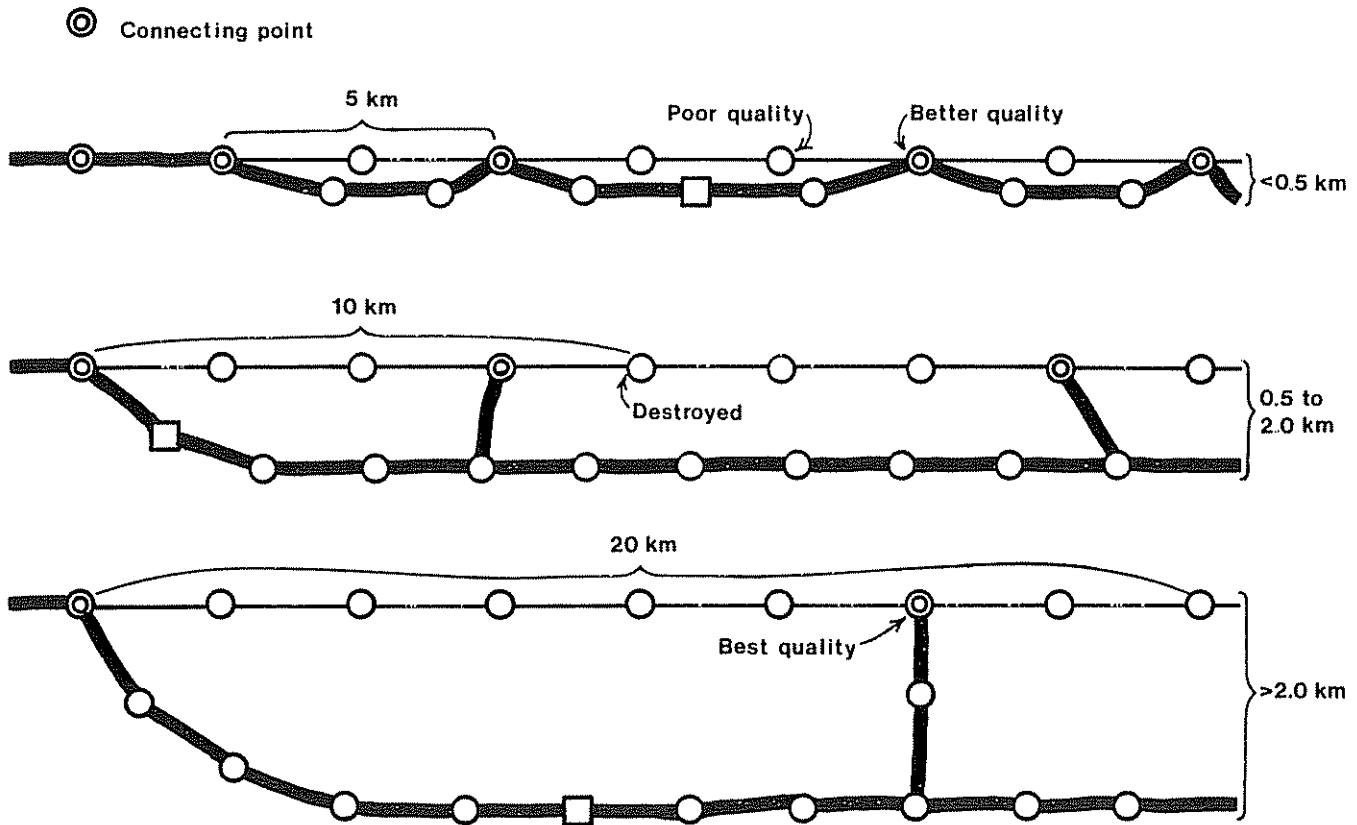

Figure 2-12.—Connections to parallel surveys.

Each primary or secondary station should have a cluster of at least five control points, a staff or electric-tape gage for measuring the height of the surface of the water relative to the points, and a water-level recorder that operates continuously. Obtain descriptions from the most recent station report. Contact the station observer to make arrangements for the leveling unit to level to the staff or gage. If no monument of quality A (sec 2.4.4) is present at a primary station, set one. Connect the points to the main line with one spur, recovering or setting another mark of quality A at the point where the spur joins the line

Airports. Connections to control points at airports provide elevations for aeronautical charting. If such points have already been leveled as part of the national network, they need not be releveled. Connect an active airport not previously leveled only if it is within 4 km (2.5 mi) of the main line, unless the connection is specifically requested in project instructions. Recover or establish only one control point, near the terminal building, if possible, or at the entrance to the airport. To locate an existing control point or to establish a new one, check with a responsible official at the airport.

Other control. Leveling connections to control points for gravity, three-dimensional, and horizontal networks

are important for monitoring crustal motion and for continual development of a unified, precise, global positioning system.

Relative measurements of gravity are made at many control points of the vertical network, so special connections to gravity stations are usually not necessary. However, connect stations where repeated measurements of absolute gravity are made, when they are listed in project instructions.

Instructions should also list any three-dimensional ("satellite") and horizontal stations that are to be connected. Otherwise, connect these stations only if they have not previously been leveled, are within 4 km (2.5 mi) of the line, and are readily accessible to the leveling unit. Consult the appropriate Geodetic Control Diagrams to determine if such stations are near the line.

At these types of stations, more than one monument may have been established. Consult the horizontal control data or other descriptions that have been provided and, if practicable, include all the monuments in the line. For example, horizontal control stations normally include a station mark, two or more nearby reference marks, and an azimuth mark a few tenths of a kilometer away. If a spur is necessary, route it over all the monuments; avoid creating a "spur-on-a-spur."

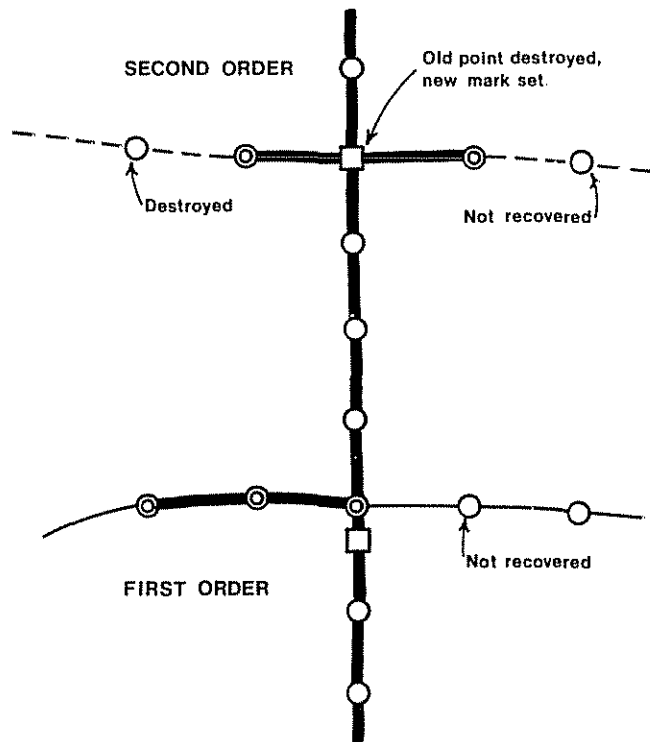

Figure 2-13.—Connections to intersected surveys.

2.3.5 Records

While routing a line, the mark setter must prepare numerous plots, descriptions, and logs, all critical to the future recovery and leveling of the control points. Plots and descriptions identify and provide permanent instructions for reaching the individual points; these are discussed in sections 2.4.3 and 2.4.4. Logs provide specific instructions to the leveling unit for leveling the line.

Logs. The logs must include clear and concise instructions that enable a unit to level efficiently to the control points along the route. Sometimes simple handwritten lists are sufficient, which briefly describe the locations of the points by providing driving instructions and measurements from the most obvious reference objects. Working position plots should be supplied with such logs. More convenient as logs are the working plots themselves, on which the plotted points and routes between them are briefly described (fig. 2-15). Prepare logs on working plots as explained here.

As each control point is recovered or established along the route, plot the control point on the appropriate topographic map. Provide a brief description by giving measurements to a witness post and other landmarks, the height of the point relative to the ground, any special leveling procedures required (such as for a vertically mounted disk or one requiring the use of spacers) and any special permission or contacts needed. If the monument site is cleared and marked with flagging, only a few of the most useful reference objects and distances supplied in the description need be noted on the log

Use a broad, light-colored pen to connect the points in leveling order on the topographic map. Note the distances and the most efficient routes between them. Label a spur intended to tie a previous survey with the accession number of the survey. Whenever points are grouped in clusters that may cause confusion, attach a large-scale sketch. Tide and water-level stations nearly always require such a sketch; attach the station reports if possible. In an urban area, a large-scale city map may provide better information than a topographic map; however, a city map should not be used to scale positions.

After each map is completed, scale the positions of the points and assign survey-point serial numbers, taking care to match them with the correct designations. (See sec. 2.4.4, "Survey-point serial number.") Label the lower right-hand corner with the line number and a number corresponding to the location of the map in the line. Fold the map, printed side out, to a convenient size.

Submitting records to the project office. Keep all mark setting records up to date as work proceeds along a line. Use the Index to Topographic Maps as a check-off list of the maps completed (fig. 2-6).

Collect and bind, in line order, descriptions of all points to be leveled, and label the binder with the line number. Bind descriptions of points not to be leveled as

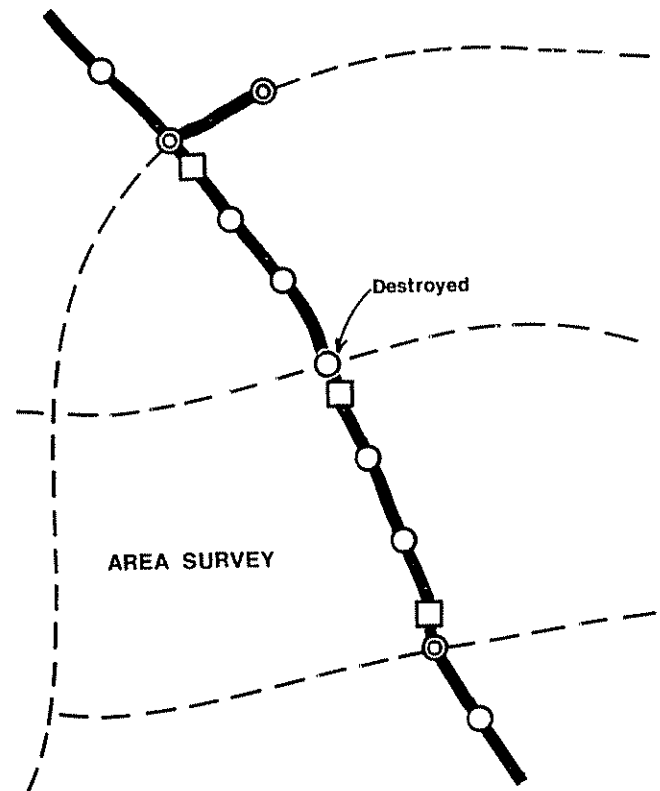

Figure 2-14.—Connections to an area survey.

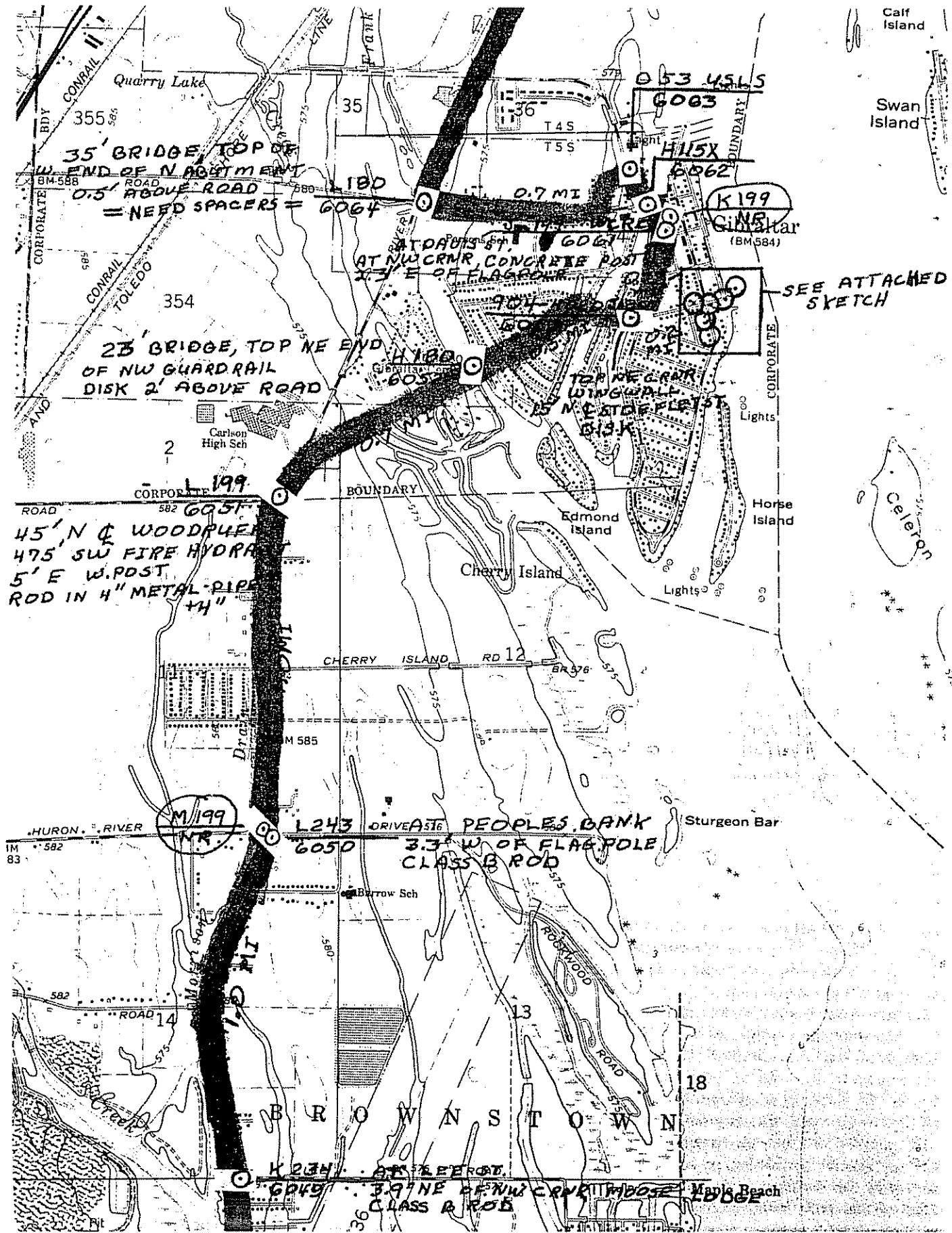

Figure 2-15.—Map prepared on a working plot.

each 30' quadrant of vertical control data is completed. Label these binders with the quadrant numbers. Submit the binders to the project office together with logs and smooth plots covering the same area.

2.4 Vertical Control Points

More than 500,000 points define the lines of the National Geodetic Vertical Network. To mark these points, monuments of many types have been set. Most of these are bench marks—monuments designed to provide permanent and stable points within the vertical frame of reference. The remaining points are marked by monuments originally designed to provide other types of control.

When routing a line of a leveling project, after existing control points are recovered, bench marks must be set to complete the routing requirements described in the previous pages. Properly recovered and set control points are the most important product of the mark setting unit. They must be permanent, stable, accessible, and properly described.

2.4.1 Control Point Recovery

An efficient recovery effort depends on adequate preparation and organization, as well as skill and experience at interpreting previous descriptions and preparing new ones. In addition to recovering or setting control points for the lines assigned by project instructions, NGS mark setting units are sometimes expected to recover and prepare descriptions for all points listed in the NGS data base and located in the area covered by the 7.5 maps that include the lines.

Preparation. First, collect and organize the data for existing control points along the line to be routed. Determine the topographic maps to be used and, if possible, plot the positions of the points to be recovered. As reminders, note on the maps the locations of line junctions and connections to be made with previous surveys, tide and water-level stations, active airports, and other control. Make arrangements to meet with appropriate officials to obtain permission and assistance. While recovering the points, keep track of their spacing, condition, and quality, noting where new bench marks should be set.

Recovering a control point. Follow the instructions given in the description for reaching each control point. Often a witness post and sometimes the monument can be seen from the vehicle after driving to the described location. However, this type of sighting is not an adequate recovery.

Before reporting a point recovered as described, be sure that the monument found is in fact the one previously described. Observe the stamping on the mark and check that it agrees exactly with that given in the description. Check the measurements and directions from nearby reference objects. If necessary, install a new witness post and make measurements to additional reference objects.

If the point is to be leveled, clear away brush or obstructions, install footholds for the rodman, and do whatever else may be necessary to make it accessible to the leveling unit. A disk recessed in concrete may not have sufficient clearance to permit a standard leveling rod to be set on the highest point. Note in the log that spacers will be required to level to such a point.

To assist the unit in finding the point, tie a single piece of brightly colored flagging at eye level around a nearby witness post, utility pole, tree, fence, or guard-rail. Chalk may be used to draw attention to a mark set in stone or concrete, but only with the property owner's permission.

Before leaving the site, plot and identify the exact location of the control point and prepare a description. The type of description prepared depends on the type of control which will be provided by the point. For example, a point that is to provide both vertical and horizontal control must have two descriptions, one for each part of the data base. Vertical control descriptions are discussed in sec. 2.4.4. Horizontal control descriptions are discussed in the Federal Geodetic Control Committee publication, *Input Formats and Specifications of the National Geodetic Survey Data Base* (Pfeifer 1980: vol. I), the National Geodetic Survey Operations Manual (Greenawalt and Floyd 1980), and *C&GS Special Publication 247*, Manual of geodetic triangulation (Gossett 1959).

When recovering a relocated point ("reset"), confirm that the original monument has been destroyed. Search for both monuments if both descriptions are available. Since the two are likely to be close together, take care that they are not confused. Prepare a separate description for each monument.

If a control point apparently cannot be recovered, recheck the description, especially the starting location, distances, turns, landmarks, and supplemental notes. Compare distances to those given for points located immediately before and after it in the line. To find a likely site, compare elevations from map contours to the published elevation for the point. Look for remnants of flagging, signal cloth, wood, witness posts, or concrete. Pinpoint the likely location of the mark by measuring from the reference objects, then clear away any brush and dig. A metal detector may be helpful. Never report a monument destroyed unless enough of the metal surface is recovered for positive identification. If no identifiable part of a monument can be found, report in the station description that the monument was not recovered and note the amount of time spent searching.

Destroyed bench marks. If a destroyed or severely damaged NGS bench mark is recovered, NGS employees or other agents designated by the agency may remove what remains of the monument from the site. Report that it is destroyed in the description and return marks bearing a stamped designation to the project office for disposal. Report destroyed or damaged monuments of other agencies, but do not remove such monuments unless the agency specifically requests it.

Occasionally a monument that is scheduled to be destroyed (e.g., during highway widening), or one that is unlikely to prove reliable in the future because of low-quality construction (quality D) or poor condition, is recovered. Set a new bench mark of better quality in the immediate vicinity and route a spur from the new mark to the old. After the spur has been leveled and checked, destroy the old monument if the responsible agency so requests, and prepare a new description accordingly. If an unreliable monument is not destroyed, be sure to note in the original recovery description that it is not recommended for future geodetic leveling.

The cap-and-bolt is an example of a type of monument likely to prove unreliable because of its construction. The monument includes two control points, a bolt set in concrete 1 to 2 m beneath the ground surface and a cap on a pipe extending to the surface from the bolt. In the past, both points were leveled from a temporary bench mark set nearby and three elevations were published (cap, bolt, and reset cap). This practice was very costly and has been discontinued. Because the monument is of quality D, replace it as described in the preceding paragraph. Since standard leveling rods are too wide to fit into the pipe, instruct the leveling unit to level only to the cap.

2.4.2 Bench Mark Setting

Only bench marks of the best possible quality (A or B) should be set to complete routing requirements for a line. The mark setting manual provides instructions for selecting sites and constructing such monuments. Information presented here is intended to supplement and update the manual.

Designations for bench marks. Only NGS employees and agents may set brass disks and aluminum flanges precast with the NGS logo. Such marks must be stamped with designations supplied by the agency in project instructions or via computer. Each designation includes a letter of the alphabet and a number, up to four digits. It should be unique among all the designations in the State where the control point is located.

Designations are normally assigned to an individual mark setter in a quantity sufficient for the line to be routed. Several series are normally assigned; each includes one number and 24 letters of the alphabet. ("I" and "O" are omitted because they may be confused with "1" and "0".) For example: A 200-km leveling line, with the space between control points averaging 1.6 km and the recovery rate expected to average 50 percent, requires approximately 63 designations or three series, such as A 123 through Z 123, A 124 through Z 124, and A 125 through Z 125.

To avoid duplicate designations, keep a record of all designations that have been used (fig. 2-16). If a mark is set that bears a stamping duplicating that of another mark in the same State, stamp it with the letter "X" following the number if it has not been leveled. For example, "C 124" becomes "C 124 X." Be sure to correct the plots, the description, and the log. If the duplication is discovered after the mark has been leveled, do not stamp the mark but notify the project office. (See sec. 5.3.3, "Synoptic file comparison.")

Site selection. Set bench marks in bedrock whenever possible. In a region where expansive soil or local subsidence is prevalent, extend a spur as much as 4 km (2.5 mi) to set a high-quality bedrock mark.

**RECORD OF BENCH MARK DESIGNATIONS
ASSIGNED BY MARK SETTER**

STATE CALIFORNIA MARK SETTER JOHN SMITH
PROJECT NGVD REGION 6 YEAR 1980

| Number | A | B | C | D | E | F | G | H | J | K | L | M | N | P | Q | R | S | T | U | V | W | X | Y | Z |
|--------|---|---|---|---|---|---|---|---|---|---|---|---|---|---|---|---|---|---|---|---|---|---|---|---|
| 123 | X | X | X | X | X | X | X | X | X | X | X | X | X | X | X | X | X | X | X | X | X | X | X | X |
| 124 | X | X | X | | | | | | | | | | | | | | | | | | | | | |
| 125 | | | | | | | | | | | | | | | | | | | | | | | | |
| | | | | | | | | | | | | | | | | | | | | | | | | |
| | | | | | | | | | | | | | | | | | | | | | | | | |
| | | | | | | | | | | | | | | | | | | | | | | | | |
| | | | | | | | | | | | | | | | | | | | | | | | | |
| | | | | | | | | | | | | | | | | | | | | | | | | |

Figure 2-16.—Example of bench mark designations assigned by mark setter.

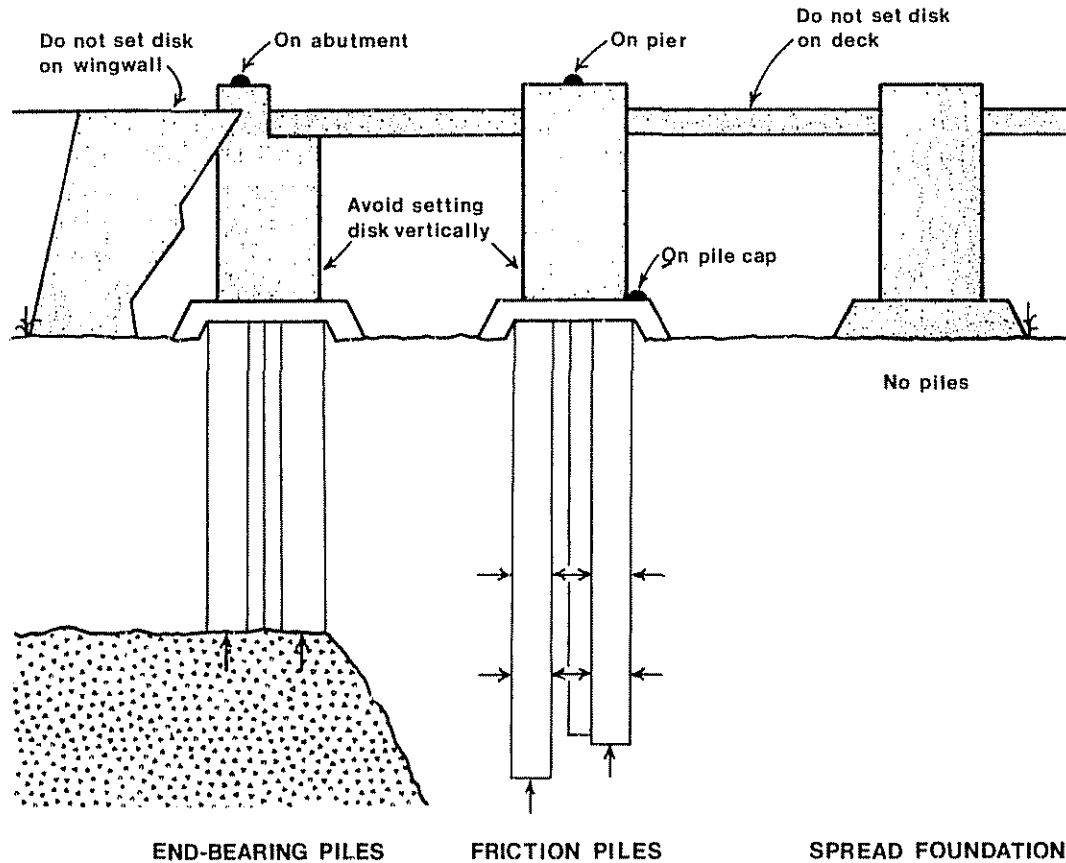

Figure 2-17.—Foundation types of massive bridges.

When selecting sites for monuments, remember the length (3 m or 10 ft) and width (7.6 cm or 3 in) of the standard leveling rod. Avoid setting marks that are awkward to level, such as those sketched in figure 3-78 (chapter 3). When setting a disk in bedrock, chip away the surrounding rock and level the disk so the highest point corresponds to the center of the disk. Hold a carpenter's level vertically, as though it were a miniature leveling rod, to test this. If a disk must be set vertically in a structure, place it about 1.0 m (3 ft) above ground and make sure the long line at the center is horizontal.

Massive bridges. A massive bridge across a wide river or valley or an overpass of an interstate highway may provide a high-quality site for a disk. Such a bridge normally has five structural members. The deck is the surface on which vehicles are driven. It is made up of several sections, separated by expansion joints, and is designed to yield to various forces. The abutments provide support to the ends of the deck. The piers provide support between the ends of the deck. Abutments and piers are in turn supported by foundations. At the ends of a bridge may be wingwalls, which are retaining walls built to hold back earthen materials.

Three types of foundations are commonly used (fig. 2-17). A spread foundation is essentially a slab that provides support by transferring the load over a large area of the soil. A friction pile transfers the load to the soil through friction at the interface of the pile and the

soil. An end-bearing pile transfers the load to a resistant subsurface formation or bedrock. Piles are usually placed in groups and topped with a pile cap. Abutments and piers rest on the pile caps. A pile cap cannot be visually distinguished from a spread foundation. Check with the local highway engineer to learn the types and depths of the foundations of bridges you might use.

To be suitable for a monument of quality A, the foundation of the bridge should rest directly on bedrock or should be made up of end-bearing piles. Where soil is nonexpansive and maximum frost depth is less than 0.5 m (1.6 ft), the foundation may be made up of friction piles. The disk must be set on an abutment, pier, or pile cap.

Rod marks. Since the publication of the mark setting manual, various driving points (fig. 2-18) have been devised. When driving a string of stainless steel rods that have been screwed together, the wings of the driving point prevent the rods from unscrewing as a result of vibration and rotation induced by the hammering of the rock drill. Use these points when setting class A or B rod marks as described in the manual.

A rod string must be driven deeply enough to resist movement caused by hammering or pulling the rod at the surface. Initial experience in driving rods with a gasoline-powered rock drill indicates that, to ensure sufficient stability, a driving rate slower than 30 cm/min (1 ft/min) must be attained at or below the minimum

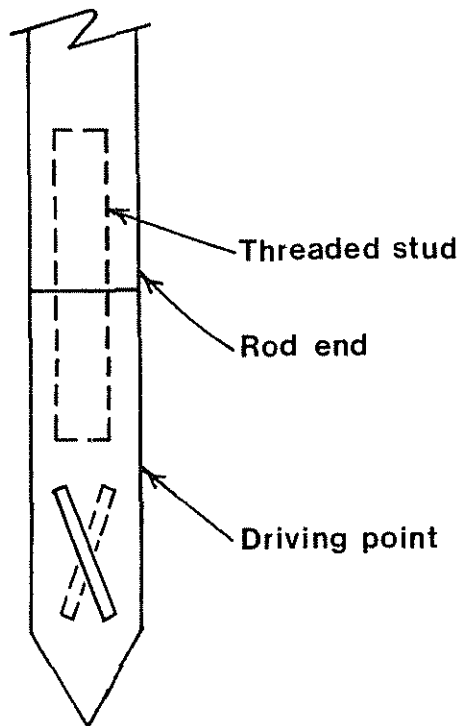

Figure 2-18.—Driving point for a rod mark.

depth required for the site. (See table 3 in the mark setting manual.) If driving through clay, do not drive more than 10 m (30 ft) when trying to attain this rate; after the rod has been in place for a few days, the clay should “set up” around it, anchoring the mark in place. If possible, return to such a mark to check that it has become anchored.

Two changes have been made to the instructions for a class B rod mark. First, instead of using a plastic clean-out fitting, protect and identify the control point with a casement exactly like the one used for a class A rod mark. (The 4-inch fitting used in the past is too narrow to permit a standard leveling rod to be placed with certainty on the highest point of every such mark.) Second, instead of crimping a brass disk to the top of the rod, round off the top end with a file or crimp a stainless steel cap onto the rod, as for a class A rod mark.

Before crimping on a stainless steel cap for either a class A or B rod mark, stamp the designation around the top of the cap, just below the edge of the rounded portion (fig. 2-19). This permits backup identification in the event that the flange of the casement is later mutilated or destroyed.

To crimp the cap, use a small hydraulic pump with a cutting attachment. After slipping the cap over the end of the rod, crimp it into the rod about halfway down from the top. Be sure that the cap cannot be raised, lowered, or twisted after crimping. Construct the casement so a leveling rod may be set and rotated on the control point without restriction.

2.4.3 Assigning Geographic Positions

The geographic positions of a small number of points in the national network of vertical control have been precisely determined by horizontal surveys. However, a position, even if approximate, should be assigned to every point for the following reasons: to permit automatic plotting and filing of vertical control data in the appropriate 30' quadrants, to permit interpolation of gravity values for correcting the leveling data, and to assist recovery without relying solely on a description of the route to the point.

Working plot. To obtain approximate positions for control points, maintain a working plot (“rough plot”). This is a 7½ topographic map (or 15' map if the larger scale is not available) on which latitude and longitude lines have been penciled. On the map, plot and verify the location of each point as it is recovered or set. If precise positions are available for some of the points, such as triangulation stations, these should be plotted in advance to assist in recovery. Plot points found destroyed, but do not plot those not recovered unless project instructions request estimated positions for them.

The accuracy of the plot depends on the mark setter's good judgment and experience. Use all the information available on the map to estimate the location of each point in relation to the surrounding topography. Consider the following elements: distance along the route from the last point; distance from one or more landmarks along the route, such as overpasses, road or highway intersections, prominent buildings, towers, powerline crossings, railroad crossings, bridges, marked

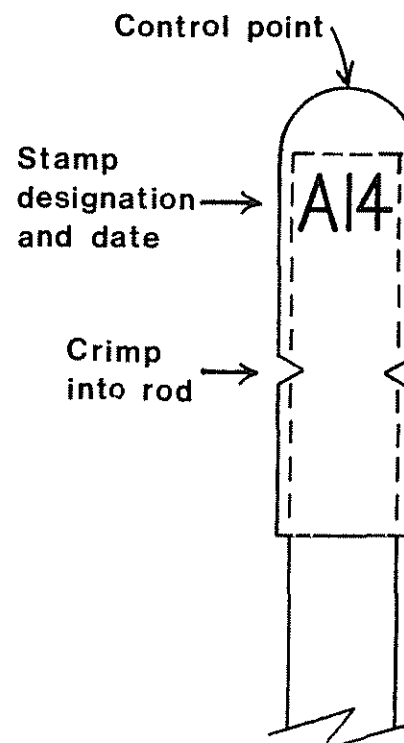

Figure 2-19.—Stainless steel cap for a rod mark.

boundaries, gullies, and hills; and distance of the point from the centerline of a highway or a rail of a railroad. When working across country, use the contour intervals to aid in locating points. After leveling, elevation differences and leveling distances should be used to check such plots. (See sec. 5.3.3, "Positions.")

Use only the most recent editions of topographic maps. If the map does not show a new highway, obtain local maps that show both the highway and section divisions (e.g., maps of the U. S. Forest Service, U. S. Bureau of Land Management, and route plans of State highway departments). Then, transfer the highway route to the topographic map by comparing section divisions. Use "bluelines" if they are available from the USGS (see sec. 2.3.1, "Maps for position plots..."), since they often show control points labeled with designations as well as new highways.

With waterproof black ink, indicate each control point with a dot, neatly surrounded by a 3-mm (1/8-in) circle. Label it with the designation. Indicate points that are not to be leveled with red ink. Indicate points that are destroyed with the note "DEST" and those that are not recovered with the note "NR." Well-maintained working plots may be used subsequently as logs for the line. (See sec. 2.3.5, "Records.")

Scaling positions. The position of each control point without a previously published position must be scaled from the working plot and recorded in the description. To ensure accuracy and consistency, scale positions only from 7.5 or 15' USGS topographic maps. The position of a single point may be scaled while preparing the description, or the positions for all the points may be scaled after work on the area is completed. In the latter case, ensure that the positions are matched correctly with the descriptions.

The scales illustrated in figure 2-20 are used to obtain both latitude and longitude. The following instructions apply to a 7.5 map. The same procedure should be used for a 15' map; however, use the single scale marked in increments of 2" from 0'00" to 5'00".

1. Place the map on a flat surface. If latitude and longitude lines have not been previously drawn, draw them on the map using a straight edge and a sharp pencil. Draw latitude lines across the map at intervals of 2'30". Draw longitude lines at the same interval. The intervals are marked on the edges and, with small crosslines, on the face of the map. (On a 15' map draw the lines at intervals of 5'.)

2. From the edge of the map, read the degrees, minutes, and seconds of the nearest latitude line below the point. If the seconds read "00," use the scale marked from 0'00" to 2'30". If the seconds read "30," use the scale marked from 0'30" to 3'00".

3. Place the scale, oriented vertically, near the control point. Adjust the lower end (0'00" or 0'30") until it rests over the nearest latitude line below the point. Adjust the upper end (2'30" or 3'00") until it rests over the nearest latitude line above the point.

4. The scale is now slightly tilted. Maintaining the same angle of tilt, move it sideways until it intersects the point, as shown in figure 2-21. Ensure that the lower and upper ends rest over the lower and upper latitude lines, as before.

5. At the control point, read from the scale the minutes and seconds to the nearest second. Add this to the reading of the lower latitude line to obtain the latitude of the point.

6. Proceed similarly to obtain the longitude. From the bottom of the map, read the degrees, minutes, and seconds of the nearest longitude line to the right of the point. If the seconds read "00," use the scale marked from 0'00" to 2'30". If the seconds read "30," use the scale marked from 0'30" to 3'00".

7. Place the scale, oriented horizontally, near the control point. Adjust the right end (0'00" or 0'30") until it rests over the nearest longitude line to the right of the point. Adjust the left end (2'30" or 3') until it rests over the nearest longitude line to the left of the point.

8. Again, the scale is slightly tilted. Maintaining the same angle of tilt, move it up or down until it intersects the point, as shown in figure 2-22. Ensure that the right and left ends rest over the right and left longitude lines, as before.

9. At the control point, read from the scale the minutes and seconds to the nearest second. Add this to the reading of the right longitude line to obtain the longitude of the point.

When scaling positions, pay particular attention to the direction in which the scale is read. In the northern hemisphere, latitude always increases as you read up (north) from the bottom edge of the map. In the western hemisphere, longitude always increases as you move left (west) from the right edge of the map. Also, watch for consistent errors of 30" caused by reading the wrong scale, errors caused by aligning one end of the scale with a latitude line and the other with a longitude line, and errors caused by reading the wrong latitude or longitude line.

To prevent such blunders, positions should be scaled by two persons independently before they are submitted to the project office. A recommended routine is for one member of the mark setting unit to plot, scale, and record the position while at the site of the control point. Then, the other member rescales and checks all the positions at the time survey-point serial numbers are assigned and logs are completed.

Smooth plot. The smooth plot is a clean version of the working plot, prepared on a copy of the same map (fig. 2-23). It is the permanent record illustrating the precise locations of the control points recovered. Label each point to be leveled with the survey-point serial number. Label the lower, right-hand corner with the line number and a sequence number corresponding to the location of the map in the line.

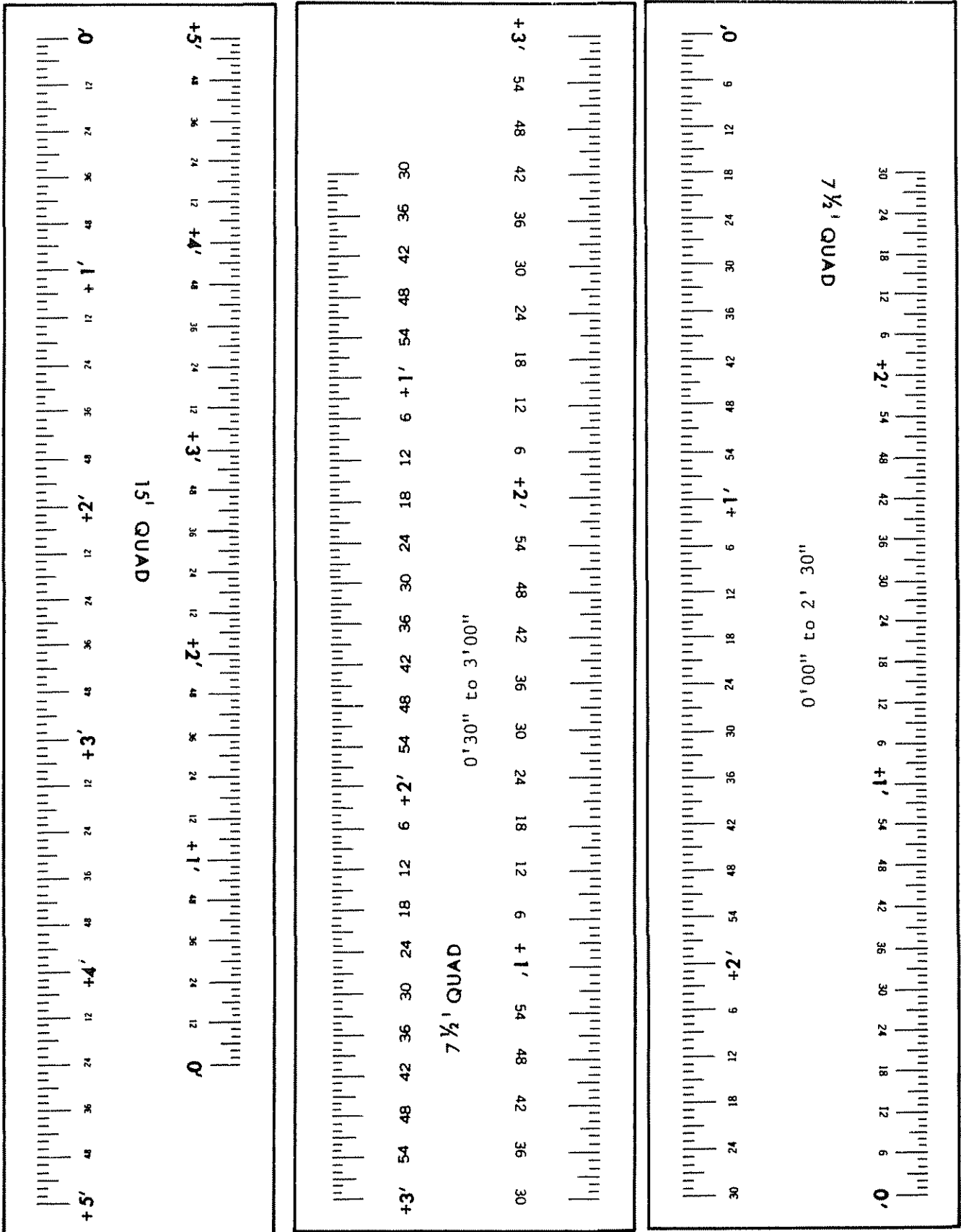

Figure 2-20.—Tools for scaling geographic positions.

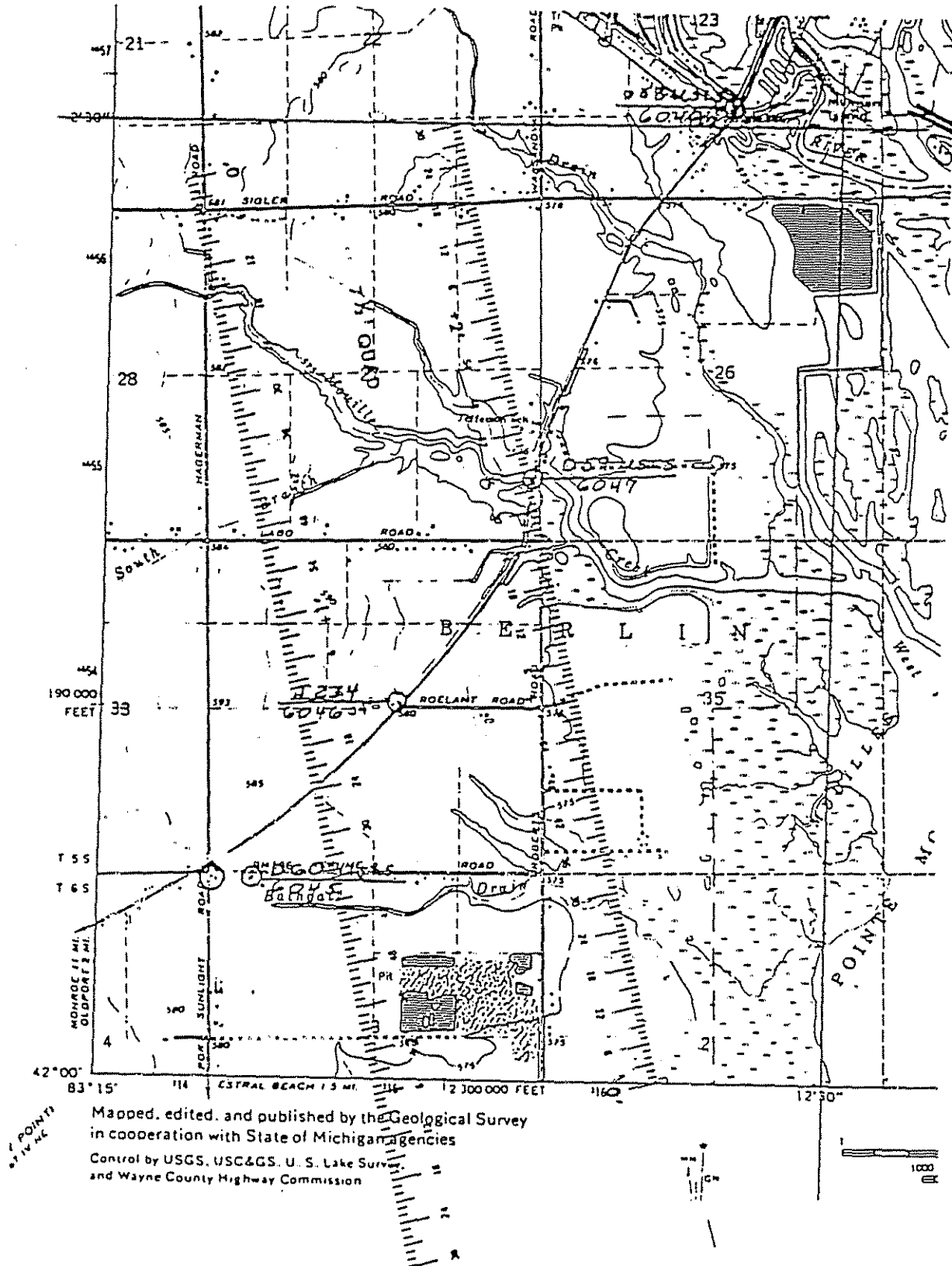

Figure 2-21.—Scaling latitude: D 59 USLS is 42°01'33"N.

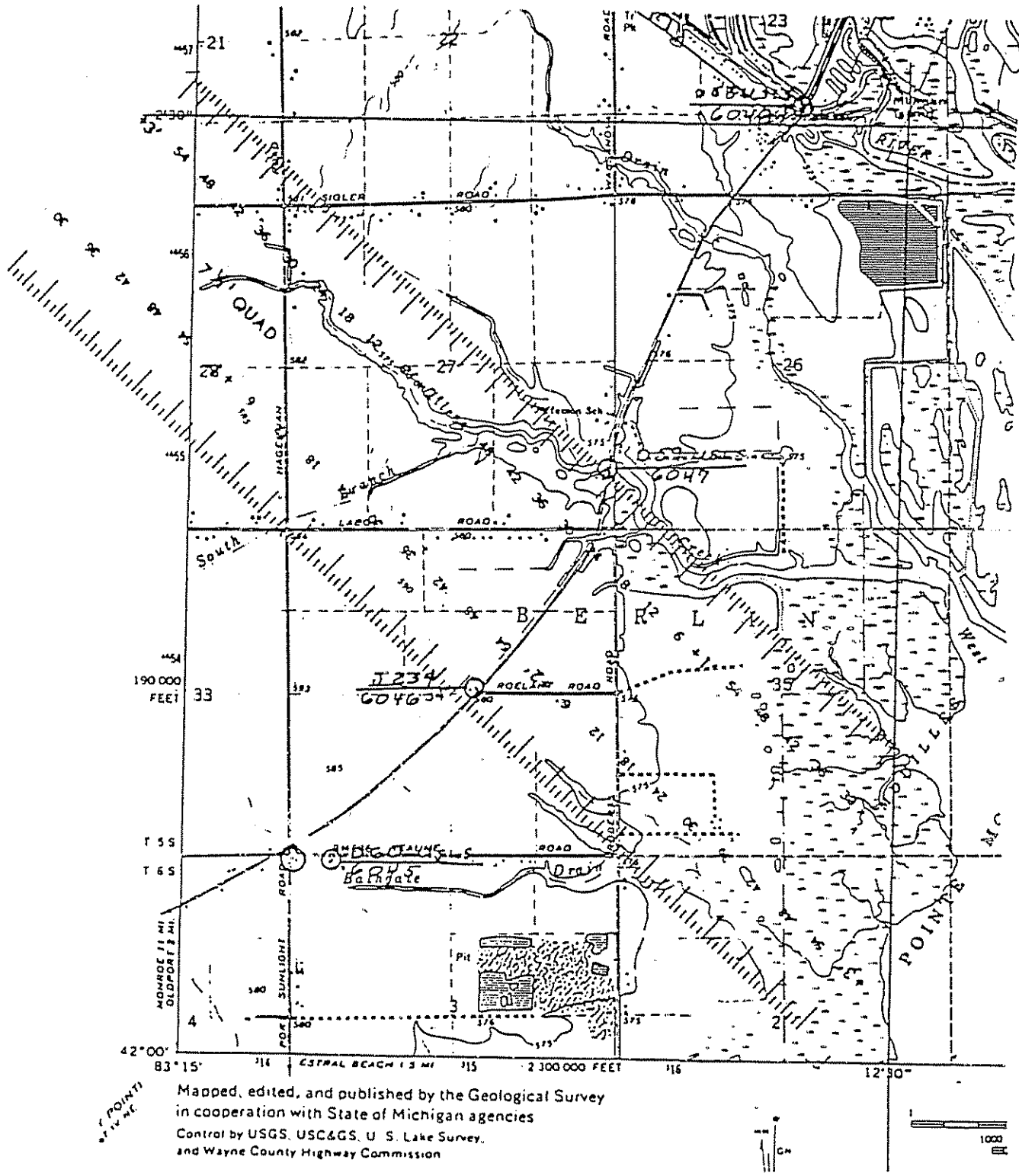

Figure 2-22.—Scaling longitude: D 59 USLS is 83°13'32"W.

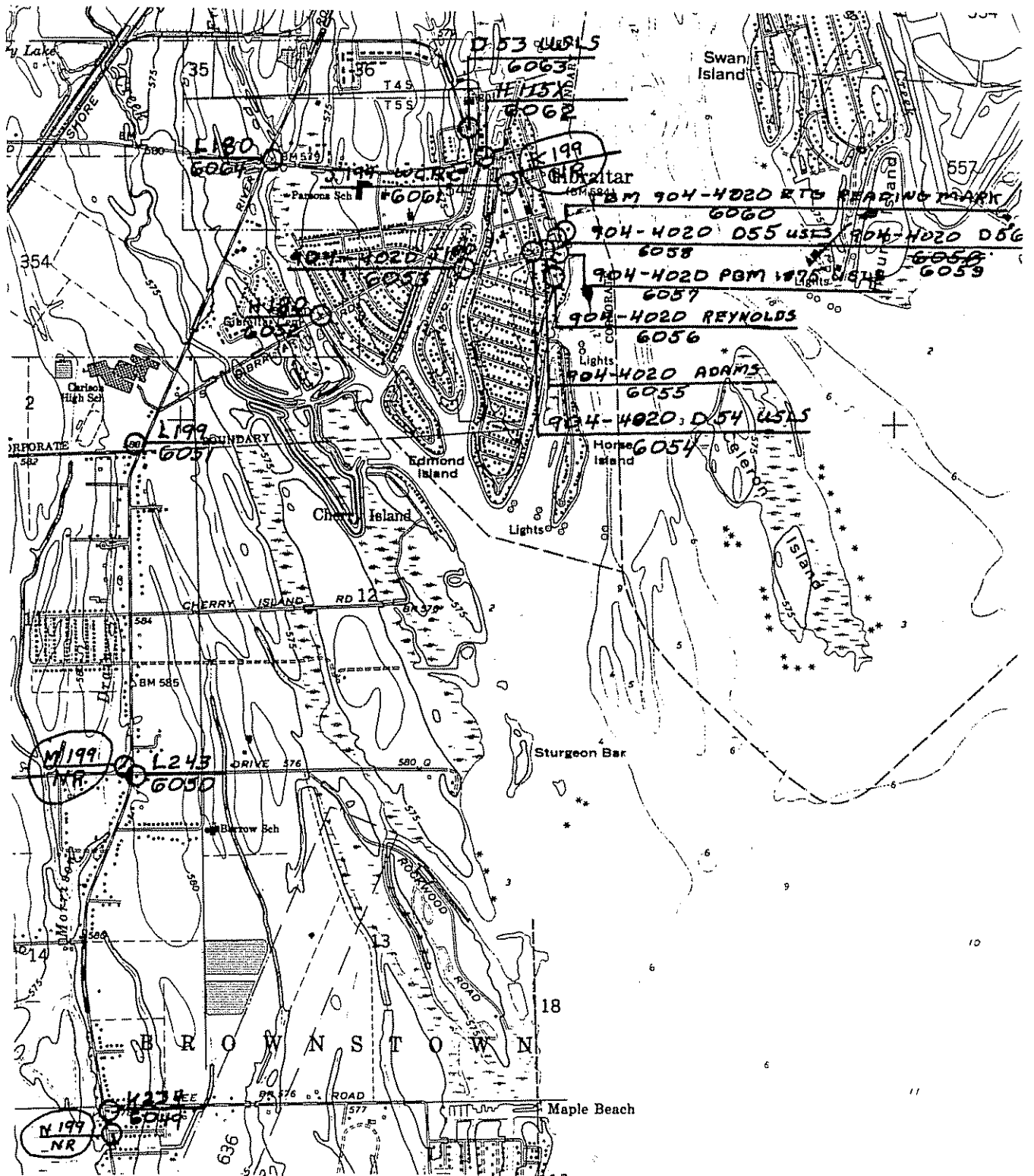

Figure 2-23.—Smooth plot.

2.4.4 Descriptions

To be useful, control points must not only be permanent and stable, but recoverable. Descriptions of points in the National Geodetic Vertical Network are the index for referring geodetic leveling data to actual points on the Earth's surface. Each description must independently provide, in a concise and consistent manner, all the information necessary to locate, positively identify, and level to a control point.

The degree of care with which a mark setter prepares descriptions is immediately evident to the other surveyors who use them. Do not repeat approximations, assumptions, and mistakes which may be present in previous descriptions. A description should contain only clear and accurate statements of facts that have been verified by the mark setter.

The National Geodetic Survey uses a form for coding much of this information, thus reducing the repetitive writing required when preparing numerous descriptions of similar points. It serves as a reminder, prompting the mark setter for detailed information about the location and the construction of the monument. It is designed to satisfy the requirements for vertical descriptive data presented in *Input Formats and Specifications of the National Geodetic Survey Data Base* (Pfeifer and Morrison 1980: volume II, ch. 7), hereinafter referred to as the input formats and specifications manual.

Prepare a description on NOAA Form 76-186, "Bench Mark Description," for each point searched for or set. Complete it at the site. Never write a description from notes or from memory; a vital piece of information may be missed or be remembered incorrectly. Only two items

may be completed after leaving the site: the survey-point serial number and the position. These may be respectively assigned and scaled while compiling logs for a completely routed segment of line.

Descriptions are original records that are referred to repeatedly during the course of a project and are filed for further use afterwards. Protect them while in the field by attaching them to a clipboard with a waterproof cover. Write neatly, printing if necessary, in waterproof black ink. Do not use abbreviations or codes except those specifically permitted in the input formats and specifications manual.

Specific items of information required for the complete description of a vertical control point are explained here in the order in which they appear on the description form. If the point is already included in the national network and only slight changes must be made to the previous description, a recovery note may be prepared on the same form. It must provide information that verifies the identity and construction of the monument; instructions to reach the point are not necessary unless the previous description is inadequate or incorrect. If the point is not recovered, do not enter information that cannot be verified. Table 2-5 summarizes the standard entries for different types of descriptions.

To begin, in the upper right-hand corner write the project line number and the name of the topographic map on which the point is plotted. (See examples in figs. 2-24 and 2-25.)

Survey-point serial number. The survey-point serial number (SPSN) is an identifier used to match leveling data with the correct control points. Assign a unique

Table 2-5—Standard entries for descriptions

| Action | Type of description | Survey Point Serial number? (*10*) | Description recovery code ¹ | Archival cross-reference number? | Other condition (*22*) | Condition ¹ (*25*) |
|---|-----------------------------------|------------------------------------|--|----------------------------------|-------------------------|-------------------------------|
| Set new bench mark | Complete | Yes | D | No | Appropriate code | not required |
| Recovered, no change or slight change in description | Recovery ² | Yes | R | Yes | Not required | G or P |
| Recovered, major change in description | Complete | Yes | R | Yes | Appropriate code | G or P |
| Recovered, first connection to the National Geodetic Vertical Control Network | Complete | Yes | R | No | Appropriate code plus X | G |
| Staff, gage mark, or other temporary control point | Temporary ¹ | Yes | None | No | Not required | Not required |
| Recovered, not leveled by this survey | Recovery ² or complete | No | R | Yes | Appropriate code | G or P |
| Recovered destroyed | Recovery ² | No | R | Yes | Not required | X |
| Not recovered | Recovery ² | No | R | Yes | Not required | N |

¹ Refer to *Input Formats and Specifications of the National Geodetic Survey Data Base* (Pfeifer and Morrison 1980: vol II)

² A recovery note requires the following entries: *10*, *13*, *15* (if any), *23*, *24*, *25*, *26*, *27*, *28*, and *30*

³ A temporary description requires the following entries: *10*, *13*

*10*DRC CODE:

D-self-standing original description
R-self-standing recovery description

*14*STATE CODE: Use standard two-letter
POSTAL CODE in the United States,
its territories and possessions.
Consult the User's Guide to the
Input Formats and Specifications
of the National Geodetic Survey
Data Base for points elsewhere.

*20/*23*AGENCY CODE:

0-unknown
1-NGS or CGS (USC&GS)
2-U.S. Geological Survey (USGS)
3-U.S. Department of Defense (DOD)
4-other federal or interstate agency
5-state agency
6-county, city, or regional agency
7-commercial organization or private firm
8-National Ocean Survey (NOS)
9-foreign government agency

*22*OTHER CONTROL CODE:

A-astronomic station
F-fault monitoring site
G-gravity station
H-horizontal control point
M-magnetic station
N-no vertical control (not presently
or anticipated to be connected to
the National Vertical Control
Network)
O-other (see descriptive text)
T-tidal bench mark
X-no vertical control (not
connected to the National
Vertical Control Network at
time of recovery, but expected
to be after this survey)

*25*CONDITION CODE:

G-GOOD or fair
N-NOT RECOVERED or not found, lost
O-other (SEE DESCRIPTIVE TEXT)
P-POOR or disturbed, mutilated
X-DESTROYED

*26*SETTING CLASSIFICATION CODE:

00-UNSPECIFIED
Shallow Settings (less than 10ft):
10-UNSPECIFIED SHALLOW
11-METAL ROD WITH BASE PLATE
12-CONCRETE POST
13-SHALLOW-SET PIPE
14-SHALLOW-SET METAL ROD
(without base plate)
Unsleeved Deep Settings:
20-UNSPECIFIED DEEP
21-COPPER-CLAD STEEL ROD
22-GALVANIZED STEEL PIPE
23-GALVANIZED STEEL ROD
24-STAINLESS STEEL ROD
25-ALUMINUM ALLOY ROD
Rocks and Boulders:
30-UNSPECIFIED ROCK
31-ROCK OUTCROP, rock ledge,
rock cut, or bedrock
32-BOULDER
Structures:
40-UNSPECIFIED LIGHT STRUCTURE
41-PAVEMENTS, such as streets, sidewalks,
aprons, curbs, etc.
42-RETAINING WALLS AND BULKHEADS, including
headwalls and wingwalls of culverts and
small bridges
43-PILES AND POLES (e.g., spike in utility pole)
44-FOOTINGS AND FOUNDATION WALLS OF SMALL OR MEDIUM
STRUCTURES
45-MAT FOUNDATIONS (bearing surface same size as
structure), such as landings, platforms,
steps, floors, tower foundations, bases of
semaphores, etc.
50-UNSPECIFIED MASSIVE STRUCTURES
51-MASSIVE RETAINING WALLS, including headwalls
and retaining walls of very large bridges
52-ABUTMENTS AND PIERS OF VERY LARGE BRIDGES,
including overpasses and underpasses
53-TUNNELS
54-MASSIVE CONCRETE, MASONRY, OR STEEL STRUCTURES
WITH DEEP FOUNDATIONS
55-LARGE CONCRETE, MASONRY, OR STEEL STRUCTURES
WITH FOUNDATIONS ON BEDROCK
Sleeved Deep Settings:
60-UNSPECIFIED ROD/PIPE SLEEVE
61-COPPER-CLAD STEEL ROD IN SLEEVE
62-GALVANIZED STEEL PIPE IN SLEEVE
63-GALVANIZED STEEL ROD IN SLEEVE
64-STAINLESS STEEL ROD IN SLEEVE
65-ALUMINUM ALLOY ROD IN SLEEVE

*27*MONUMENTATION CODE:

B-BOLT
C-CAP-AND-BOLT
D-SURVEY DISK (any type)
F-FLANGE-ENCASED ROD
H-DRILL HOLE
I-METAL ROD
N-NAIL
O-CHISELED CIRCLE
P-PIPE CAP
Q-CHISELED SQUARE
R-RIVET
S-SPIKE
T-CHISELED TRIANGLE
V-STONE MONUMENT
X-CHISELED CROSS
Z-SEE DESCRIPTIVE TEXT

*27*DISK TYPE (blank if not survey disk):

00-unspecified SURVEY DISK
01-BENCH MARK DISK
02-TIDAL BENCH MARK DISK
03-TRIANGULATION STATION DISK
04-TRAVERSE STATION DISK
05-TOPOGRAPHIC STATION DISK
06-SURVEY DISK (not listed)
07-REFERENCE MARK DISK
08-AZIMUTH MARK DISK
09-GRAVITY STATION DISK
10-GRAVITY REFERENCE MARK DISK
11-MAGNETIC STATION DISK

*27*QUALITY OVERRIDE (for NGS use only)*40*/*41*/*42*/*43*UNITS CODE:

E-English M-metric units

*43*POINTS OF COMPASS: N, NNE, NE, ENE,
E, ESE, SE, SSE, S, SSW, SW, WSW, W, WNW, NW, NNW.

Figure 2-25b.—Recovery note.

serial number to every point that is to be leveled in the line. A series of numbers for each line is normally assigned in the project instructions. Assign the number "0000" to a point that is not to be leveled, such as one that is destroyed, unsuitable, or not recovered.

To prevent duplications, serial numbers may be assigned to all the points on a completed map at the same time that positions are scaled. They may be assigned in a sequence corresponding to the order in which the points should be leveled. However, they need not always appear in sequence. If points are added to the line after most serial numbers have been assigned, do not change the original numbers merely to correct the sequence.

Junction code. Write "JUNCTION" at the top of the description form whenever the control point is one of the following:

1. One of the three points at network junctions (including international boundaries).
2. A point at the base of a spur connecting a primary tide station.

A junction point leveled repeatedly within the same project must be described for each line in which it is leveled. If it is newly set, prepare a complete description for the first line leveled; prepare a recovery note for each subsequent line. For convenience, assign the same survey-point serial number to the point whenever it is described.

Description/recovery code (DRC). Enter a single letter on line *10* to indicate whether the control point was searched for, "R," or is newly set, "D." The code "R" indicates a recovery note or a complete description, written for a point that existed prior to the arrival of the mark setter. The code "D" indicates a complete description, written at the time the mark is set.

Position Scale the latitude and longitude of the plotted position of the control point from the topographic map. Record each to the nearest second, latitude followed by the direction, "N" or "S", from the equator and longitude followed by the direction, "W" or "E", from the Greenwich meridian. The position is used by NGS to compute automatically the 30' quadrant and the number of the quadrant line in which data for the point are filed.

If a point is not recovered, enter on line *11* the number of the quadrant and on line *12* the number of the quadrant line in which the previous description was published. Do not enter a position.

Archival cross-reference number. The archival cross-reference number (XRN or ACRN) is a unique identifier that is assigned to each control point in the national network. It permits the comparison of data collected during different epochs for the same point. It consists of two parts, a two-letter area code, indicating the Geodetic Control Diagram in which the point is positioned, and a four-digit number that is unique within the area. An index of two-letter area codes appears in appendix B.

Obtain the cross-reference number from either the published description or from a special listing of the

synoptic file provided by NGS. Copy the number on line *11* of the description form. If a point has not previously been connected to the network, leave the space blank; a cross-reference number is automatically assigned after the project is completed.

Designation. To identify the control point, a designation is normally stamped on the mark by the agency which sets it. The designation is a unique name by which the point can be conveniently recognized and referenced. In general, the designation given in the description should be identical to that stamped on the mark. It should not, however, include redundant or nonspecific information that may appear in the stamping.

When the point is recovered, assign the designation given in the published description (or listing of the synoptic file). If necessary, correct mistakes such as misspellings or transposition of numbers, and record the previous, incorrect designation as an alias. Use the following guidelines to standardize the designations. (Examples appear in table 2-6.)

Do not include information that is normally precast on a mark, such as warnings or type of control.

Do not include a stamped elevation unless it is the only means of distinguishing the point.

Do not include a stamped date, unless the point has been relocated or the date is the only means of distinguishing between otherwise duplicate designations.

Limit the designation to 25 characters or less, including imbedded blanks. Abbreviate the designation if necessary to conform to this limit. Separate groups of alphabetic and numeric characters with one blank. Do not retain any punctuation that is stamped, except the following: A plus (+); a minus (-), only if it indicates a negative elevation; a period (.), only if it is embedded in a group of numerals; an equal sign (=); or a slash (/). Do not separate such symbols from the adjacent characters with blanks. Note: If a minus (-) is included, it can only be the first character of the designation.

If the mark is stamped with two designations, totaling 24 characters or less, concatenate the designations with an equal sign. If the characters total 25 or more, enter one of the designations as an alias.

If the mark belongs to an agency other than the NGS (or its predecessor, the Coast and Geodetic Survey), include at the end of the designation the acronym for the agency's name that is precast on the mark. If no name is precast, include the same acronym that is entered for the agency that set the mark. (See "Setting information," this section.)

If the mark provides control for a tide or water-level station, but was set primarily to provide control for the national network, include the station number as an alias. If the mark was set solely to provide control at the station, include the seven-digit number in the designation. Enter the first three digits, a space, and the last four digits. Add the word "TIDAL" if the station is a tide station. Then, enter the designation stamped on the mark, observing the guidelines given in this section. Newer

Table 2-6.—Examples of bench mark designations

| Stamping as it appears on mark | Symbol for agency name as it appears on mark | Designation to appear on description |
|--------------------------------------|---|--|
| General: | | |
| C 124 1980 | NGS | C 124 |
| 2903 | USGS | 2903 USGS |
| H 325 1945 230 695 FT | USCGS | H 325 |
| 140B ELEV 95 3 FT | MORC | 140 B MORC |
| T T17B 1965 | USGS | TT 17 B USGS |
| TT-17B 1965 | USGS | TT 17 B USGS |
| 595 +00 1952 | AHD | 595+00 AHD |
| MI 14 2 | None | MI 14 2 |
| 4419 | USGS | 4419 USGS |
| 5301 29 FT | USGS | 5301 29 USGS |
| CH1174, 297+00A | USGS | CH 1174=297+00 A USGS |
| STA NO 3, MI 182 5 | None | STA NO 3=MI 182 5 |
| No stamping | None | <i>Previous designation</i> |
| Tide station 872 8912: | | |
| TIDAL 1 1937 | USCGS | 872 8912 TIDAL 1 |
| BASIC 1937 | USCGS | 872 8912 TIDAL BASIC |
| H 14, TIDAL 3 1963 | USCGS | H 14=872 8912 TIDAL 3 |
| 8912 A 1977 | NOS | 872 8912 A TIDAL |
| A 307 1974 | NGS | A 307 <i>Alias</i> 872 8912 TIDAL |
| No stamping | USCGS | 872 8912 TIDAL <i>Previous designation</i> |
| Staff, rod held at 6 ft stop | | TBM 872 8912 STAFF 6 FT |
| Water-level station 906 3000: | | |
| 2 1934 | USCGS | 906 3000 2 |
| BM 3 1934 | USCGS | 906 3000 BM 3 |
| POOL 1934 | USCGS | 906 3000 POOL |
| M 104 1973 | NGS | M 104 <i>Alias</i> 906-3000 |
| 3000 B 1977 | NOS | 906 3000 B |
| No stamping | USCGS | 906 3000 <i>Previous designation</i> |
| Electric tape-gage reading mark | | TBM 906 3000 ETG READ MK |
| Other control: | | |
| BOULDER 1935 | USCGS | BOULDER |
| BOULDER NO 2 1935 | USCGS (Reference disk) | BOULDER RM 2 |
| BOULDER 1935 | USCGS (Azimuth disk) | BOULDER AZ MK |
| BOULDER NO 2 1935 | USCGS (Azimuth disk) | BOULDER AZ MK 2 |
| CHARLOTTE | USGS | CHARLOTTE USGS |
| CHARLOTTE NO 1 | USGS (Reference disk) | CHARLOTTE RM 1 USGS |
| CHARLOTTE | USGS (Azimuth disk) | CHARLOTTE AZ MK USGS |
| PALMER N E BASE 1940 | USCGS | PALMER NE BASE |
| N WASH AZI | USGS | N WASH AZ MK USGS |
| Relocated points: | | |
| Z 201 RESET 1980 | NGS | Z 201 RESET 1980 |
| 3000 USGS RESET 1976 | NGS | 3000 USGS RESET 1976 |
| CHICO 1948 1971 | NGS | CHICO 1948 1971 |
| CHICO 1948 NO. 3 1971 | NGS (Reference disk) | CHICO RM 3 1948 1971 |
| CHICO 1948 1971 | NGS (Azimuth disk) | CHICO AZ MK 1948 1971 |
| CHICO 1948 NO. 2 1971 | NGS (Azimuth disk) | CHICO AZ MK 2 1948 1971 |
| LIGHT 1950 RESET 1955 | USCGS | LIGHT RESET 1955 |
| WINSLOW 2 1962 | USCGS | WINSLOW 2 |
| LAKE WASHINGTON 1950 1970 | USCGS | LAKE WASHINGTON 1970 |

tide and water-level marks are stamped with the last four digits of the station number and a letter; in this case, enter the three-digit state code followed by a space, the stamping, and the word "TIDAL."

If a point at a tide or water-level station has no stamping, append the designation given in the previous description to the station number. Because a staff or the

reading mark of an electric tape gage is not a permanent monument, enter the letters "TBM" at the beginning of the designation, to indicate a temporary bench mark. Designate a staff by the station number, the word "STAFF," and the height of the stop on which the leveling rod is to be held. Designate the reading mark of an electric tape gage by the station number and the words "ETG READ MK."

If the mark was set to provide control for a horizontal network or other types of networks, assign the designation as it appears in the published description, again observing the guidelines given here. Designate a reference mark with the horizontal station name, the letters "RM," and the number stamped on the mark. Designate an azimuth mark with the horizontal station name, the letters "AZ MK," and the number, if any, stamped on the mark.

The mark for a vertical control point that has been relocated is normally stamped with the original designation, the word "RESET," and the year of relocation. Include all of this information in the designation. Other types of relocated control points may be stamped differently. For example, to reestablish a horizontal control point, a new surface mark may have been reset directly over an underground mark. The reset mark is usually stamped with two dates, the year the point was established and the year it was reestablished. The geographic position has not changed, but the elevation has. Indicate this in the designation by including both dates. If the designation exceeds 25 characters in length, include only the most recent dates.

A horizontal control point that has been entirely relocated and designated with the number "2" should not be confused with a reestablished point. Do not designate such a point with a date unless it, too, has been reestablished.

Alias. If the control point is known by more than one designation, enter the designation that is stamped on the mark on line *13* and enter all other designations as aliases. If the point has been designated incorrectly in a previously published description (or in the listing of the synoptic file), the incorrect designation should be shown as an alias in the corrected description.

General location. For control points in the United States enter a two-letter postal code indicating the State, commonwealth, province, or territory on line *14*. United States postal codes are given in table 2-2. Then enter the county, parish, census division, or independent city in which the point is located. Indicate a city with the phrase "C OF." For example, "C OF ST LOUIS" for St. Louis, Missouri.

For control points in other countries, enter the appropriate two-letter code and then the primary political division, such as a State, province, or district. The codes are published in annex A of the input formats and specifications manual.

If the point is part of a local network, such as a network for monitoring subsidence, an area title may be entered on line *16* to indicate this. The entry is optional and can be automatically added to all appropriate points after completion of the survey.

On line *17* enter the nearest city or town. It must have a post office, railroad station, or well-defined highway crossroads from which to begin distance measurements and it must appear on the official State highway map. If it is in a different State from the point,

append the postal code for the state whenever the city or town is named. Also, append the code when necessary to avoid confusion. For example, "KANSAS CITY KS" as opposed to "KANSAS CITY MO."

The distance from the nearest city or town, which is to be entered on line *18*, is not a straight-line measurement. Instead, it is the total of the distances given in the instructions to reach the point, by following the most direct highway routes. Enter it to the nearest tenth of a kilometer, followed by the mileage in parentheses and the direction traveled. Abbreviate kilometer, "KM," and mile, "MI." Use the eight-point compass, spelling out the four cardinal directions and abbreviating the four intercardinal points. For example, "3.4 KM (2.1 MI) EAST," "10.2 KM (6.3 MI) NW," and "1.0 KM (0.6 MI) SE."

If the control point is located within city or town corporate limits, enter the word "IN" before the name of the city or town and do not give a distance and direction.

Setting information. Whenever the control point requires a complete description, enter information about the agency which set the monument and its purpose. This includes a code indicating the agency classification, the agency's name, the date (year) the mark was set, and the initials of the project director of the party which set it. Agency codes are listed on the back of the description form and in table 2-7. Acronyms for agency names, as standardized for the use of the National Geodetic Survey, are given in annex C of the input formats and specifications manual. If the date the mark was set and the initials are not available from a previous description, enter the date stamped on the mark and leave the initials blank. If the date is not known, enter "UNK" in its place.

When the point serves another geodetic or geophysical purpose enter the appropriate code on line *22*. The purpose should be evident from the project instructions for newly established points and from the previous description or type of disk for recovered points. Spe-

Table 2-7.—Agency classification codes designated by NGS for preparing NOAA Form 76-186

| Agency | Code ¹ |
|--|-------------------|
| National Geodetic Survey | 1/NGS |
| National Ocean Survey | 8/NOS |
| U.S. Coast and Geodetic Survey (prior to 1970) | 1/CGS |
| U.S. Geological Survey | 2/USGS |
| U.S. Department of Defense | 3/DOD |
| Other Federal or interstate agency | 4 |
| State agency | 5 |
| County, city, or public regional agency | 6 |
| Commercial organization or private firm | 7 |
| Foreign government agency | 9 |
| Unknown | 0 |

¹ Refer to *Input Formats and Specifications of the National Geodetic Survey Data Base* (Pfeifer and Morrison 1980: vol II)

cific horizontal, astronomic, or gravity data must be available in the NGS data base if the point is to be coded as providing such control. Control classifications appear on the back of the form and in table 2-8.

If a recovered point has not been previously connected to the national network, but it is connected by the current survey, enter "X" in addition to any other codes. If a point is described that has not been connected to the network in the past and is not connected by the current survey, enter "N" (A description is only required for such a point if it is marked by a disk or flange belonging to NGS).

Recovery information. In each recovery description, enter information about the agency which searched for the point. This includes a code indicating the type of agency, a standard abbreviation for the agency's name, the year the point is searched for, and the initials of the project director of the party conducting the search. Use the same codes and abbreviations that appear in tables 2-6 and 2-7 to denote the setting agency.

Enter a code for the condition of the monument on line *25*. If the monument appears to be undisturbed and is suitable for leveling, in good or fair condition, enter "G." If it has been disturbed, or if it cannot be positively identified because of mutilation, enter "P". If the monument is found destroyed enter "X". (See sec. 2.4.1, "Destroyed bench marks.") If it is not recovered, enter "N", even if it is presumed to have been destroyed. Explain any condition other than good in the descriptive text.

Construction details. Describe the construction of the monument by entering the two-digit code that denotes the setting classification. Table 2-9 summarizes setting classifications. If the monument is a mark installed in a preexisting structure (codes 40 through 55), describe the setting specifically with a short phrase on line *26*. For example, "51/ VERTICAL IN OVERPASS HEADWALL," "42/CULVERT," and "44/ VERTICAL IN BUILDING FOUNDATION."

Table 2-8.—Control classification codes designated by NGS for preparing NOAA Form 76-186

| Other control | Code ¹ |
|---|-------------------|
| Fault monitoring | F |
| Tide or water-level | T |
| Horizontal | H |
| Astronomic | A |
| Gravity | G |
| Magnetic | M |
| Other (explain in text) | O |
| Not previously connected to the National Geodetic Vertical Network: | |
| Connected by the current survey | X |
| Not connected by the current survey | N |

¹ Refer to *Input Formats and Specifications of the National Geodetic Survey Data Base* (Pfeifer and Morrison 1980: vol II)

Table 2-9.—Monument classification codes designated by NGS for preparing NOAA Form 76-186

| Code | Setting classification | Quality ¹ |
|--|---|----------------------|
| 00 | Unspecified | D |
| Shallow settings (less than 3 m or 10 ft): | | |
| 10 | Unspecified shallow | D |
| 11 | Metal rod with base plate | C |
| 12 | Concrete post | C |
| 13 | Shallow pipe | D |
| 14 | Shallow metal rod without base plate | D |
| Unsleeved deep settings: | | |
| 20 | Unspecified deep | C |
| 21 | Copper-clad steel rod | B |
| 22 | Galvanized steel pipe | B |
| 23 | Galvanized steel rod | B |
| 24 | Stainless steel rod | B |
| 25 | Aluminum alloy rod | B |
| Rocks and boulders: | | |
| 30 | Unspecified rock | B |
| 31 | Rock outcrops, such as a rock ledge, rock cut, or bedrock | A |
| 32 | Boulder | C |
| Light structures: | | |
| 40 | Unspecified light structure | D |
| 41 | Pavements, such as streets, sidewalks, aprons, curbs, and so forth | D |
| 42 | Retaining walls and bulkheads, including headwalls and wingwalls of culverts and small bridges | C |
| 43 | Piles and poles, such as a spike in utility pole | D |
| 44 | Footings, foundation walls, and abutments of small or medium size structures | C |
| 45 | Mat foundations, such as landings, platforms, steps, floors, tower foundations, semaphore bases, and other bearing surfaces of the same size as the structure | C |
| Massive structures: | | |
| 50 | Unspecified massive structure | B |
| 51 | Massive retaining walls, including headwalls and wingwalls of very large bridges | B |
| 52 | Abutments and piers of very large bridges | B |
| 53 | Tunnels | B |
| 54 | Massive concrete, masonry, or steel structures with deep foundations | A |
| 55 | Large concrete, masonry, or steel structures with foundations on bedrock | A |
| Sleeved deep settings: | | |
| 60 | Unspecified rod or pipe in sleeve | B |
| 61 | Copper-clad steel rod in sleeve | B |
| 62 | Galvanized steel pipe in sleeve | A |
| 63 | Galvanized steel rod in sleeve | A |
| 64 | Stainless steel rod in sleeve | A |
| 65 | Aluminum alloy rod in sleeve | A |

¹ Refer to *Input Formats and Specifications of the National Geodetic Survey Data Base* (Pfeifer and Morrison 1980: vol II)

If the monument is a concrete post (code 12), describe the height of the post with respect to the ground surface in metric units on line *40*. Similarly, if the monument is a rod or pipe which has been driven into the ground (codes 11, 13, 14, 20-25, or 60-65), give the depth, the sleeve depth (if any), and the height of the

casement with respect to the ground surface in metric units on line *41*.

Describe the type of device marking the control point by entering the appropriate one-letter code on line *27*. If the mark is a survey disk, enter a two-digit code to indicate the type. A list of marks and corresponding codes is given on the back of the form and in table 2-10. Figures 2-26 and 2-27 show the bench mark disks used by the former Coast and Geodetic Survey and the National Geodetic Survey.

Quality classification. In addition to the variety of monuments set by NGS, monuments of even greater diversity, set by other Federal, State, and local agencies, have been and continue to be included in the national network. See appendix D of the mark setting manual. To assist the user of vertical control data in selecting the most reliable control points for the purpose of the intended survey, monuments have been classified according to their expected ability to remain stable in relation to the local topography. One of four quality codes is automatically assigned to each control point on the basis of the construction details provided in the description. The codes are defined as follows:

1. Quality A describes a monument of the most reliable construction, likely to be affected only by movement of the geological feature in which it is installed.

Table 2-10.—Bench mark classification codes designated by NGS for preparing NOAA Form 76-186

| Type of mark | Code ¹ |
|--|-------------------|
| Survey disk: | |
| Unspecified | D 00 |
| Bench mark (vertical control) | D 01 |
| Tide or water-level bench mark | D 02 |
| Triangulation station (horizontal control) | D 03 |
| Traverse station | D 04 |
| Topographic station | D 05 |
| Reference mark | D 07 |
| Azimuth mark | D 08 |
| Gravity station | D 09 |
| Gravity reference mark | D 10 |
| Magnetic station | D 11 |
| Other type (explain in text) | D 06 |
| Flange-encased rod | F |
| Metal rod | I |
| Pipe cap | P |
| Cap-and-bolt | C |
| Bolt | B |
| Rivet | R |
| Nail | N |
| Spike | S |
| Chiseled cross | X |
| Chiseled circle | O |
| Chiseled square | Q |
| Chiseled triangle | T |
| Drill hole | H |
| Stone monument | V |
| Other (explain in text) | Z |

¹ Refer to *Input Formats and Specifications of the National Geodetic Survey Data Base* (Pfeifer and Morrison 1980: vol 11)

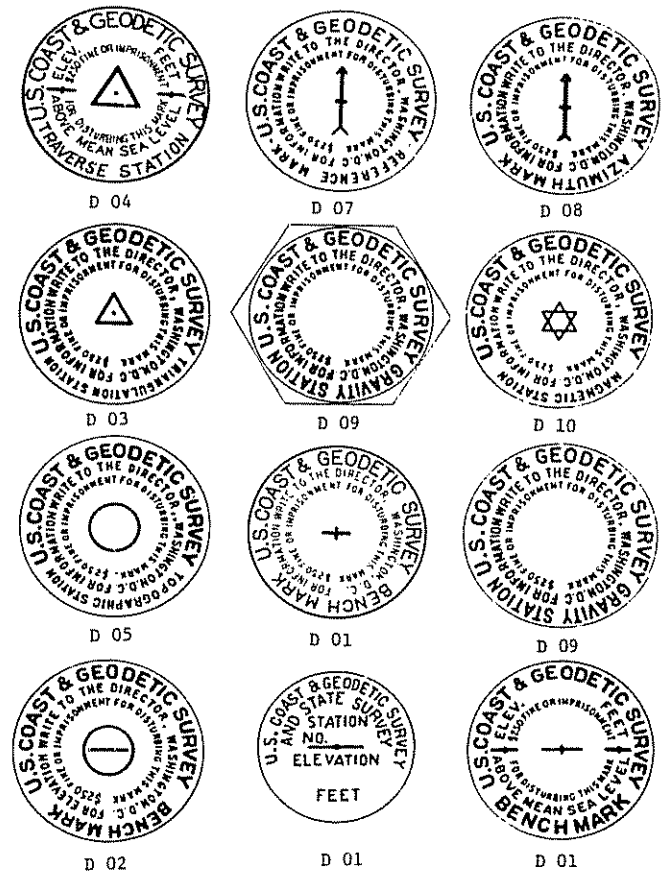

Figure 2-26.—Survey disks of the former U.S. Coast and Geodetic Survey.

2. Quality B describes a monument of construction likely to prove reliable.
3. Quality C describes a monument that may be affected by surface movement, such as frost heave or the shrinking and swelling of certain clays.
4. Quality D describes a monument not likely to prove reliable, or a monument of unknown construction.

Of course, generalizations have been necessary to implement this system. However, the experienced mark setter may greatly improve the value of the quality estimate by assigning the code in the field. A monument of low expected quality in one location might require a higher classification in another. For example, an unsleeved stainless steel rod (quality B) is subject to movement due to soil shrinkage or expansion in regions where the soil readily absorbs and retains water. In regions with low humidity, rare frost, and nonexpansive soil, the same monument may be upgraded to quality A.

Similarly, a monument of high expected quality might, when construction details are examined, require a lower classification. For example, a disk set in the wingwall of a very large bridge (quality B) is less likely to prove reliable if the wall is cracked and undercut by erosion (quality C).

More details on placement and construction of monuments are presented in section 2.4.2 and in the mark setting manual. Using table 2-9 as a guideline, apply your

judgment in specific cases to assign a more realistic estimate of quality when it is appropriate. Enter the quality code after the setting classification.

Stamping. A control point marked with a disk flange-encased rod, pipe cap, or cap-and-bolt is normally stamped with the designation and year it was set. Sometimes an elevation may be stamped as well. A precast inscription is not considered part of the stamping.

The stamping serves as final verification of the identity of the control point. Enter it exactly as it appears on the mark. If no stamping appears, make note of it in the descriptive text.

From the precast inscription (if any), determine the originating agency for the mark. In the space following the stamping, enter the acronym for the agency as it appears on the mark.

Text. The text ("body") of the description must provide thorough and accurate instructions for reaching the control point. It should also describe features affecting the utility of the point for vertical control, clarifying information coded elsewhere in the description when necessary.

The fact that a control point is recovered by following instructions from the previous description does not, in itself, imply that the instructions are correct in every detail or that they will apply in the future. Verify all items in the previous instructions and assess their future usefulness. If no changes are necessary, the recovery note need not include a text entry. If brief corrections or additions are necessary, enter them. Here are two examples: "The 1935 description is adequate except

that the sign 'JONES FARM' no longer exists"; and "The 1952 description is adequate. The point is 0.5 meter (1.6 ft) south of a witness post."

When a point is found destroyed or cannot be recovered, describe the situation. Here are three examples: "The concrete post was found broken off at the base and the disk was removed at this time." "After a 30-minute search by two persons, the point was not recovered. Reference objects given in the 1948 description were not found." "The bridge mentioned in the 1952 description has been rebuilt and the mark appears to have been destroyed."

If a point is particularly difficult to recover, the previous instructions are probably not adequate even though they may be correct. In such cases, and whenever major corrections are necessary, prepare a complete new description, including in the text a new set of instructions to reach the point.

Present instructions in a consistent, clear, and concise format. Start from a major highway intersection or a prominent, permanent landmark in the nearest city or town. Mention landmarks and reference objects in the order in which they will be used. Lead the surveyor first to the general vicinity of the monument and then to the exact point. For convenience, treat these two portions of the description separately, as shown in figure 2-24.

The instructions to reach the general vicinity should follow the most direct driving route (not necessarily the leveling route). Identify highways by Federal, State, or county number. To ensure that the measured distances between landmarks and turns are accurate, calibrate your vehicle's odometer. Enter distances to the nearest tenth of a kilometer, followed in parentheses by miles to the nearest half-tenth. Enter compass directions to the nearest cardinal or intercardinal point: north, northeast, east, southeast, and so forth. When describing a turn or the location of a landmark, enter a compass direction, followed by "right" or "left" in parentheses.

Since vehicle odometers differ, if driving distances are long, give distances to intermediate landmarks that can serve as check points. In addition to noting turns, mention a prominent landmark visible from the highway as near to the control point as possible, at least within the final kilometer. Within city or town corporate limits, include the address (if any) of the property on which the point is situated.

For a control point located about halfway along the line between two cities or towns, include driving instructions from each town, prefacing the second set of instructions with the word "also."

Once in the general vicinity, direct the surveyor to the point by listing measured distances and directions from nearby reference objects in an order convenient to the recovery of the mark. Begin with the most conspicuous object or the longest distance. A good practice is to enter first the distance and direction from the centerline of the highway, so the surveyor can search on the appropriate side.

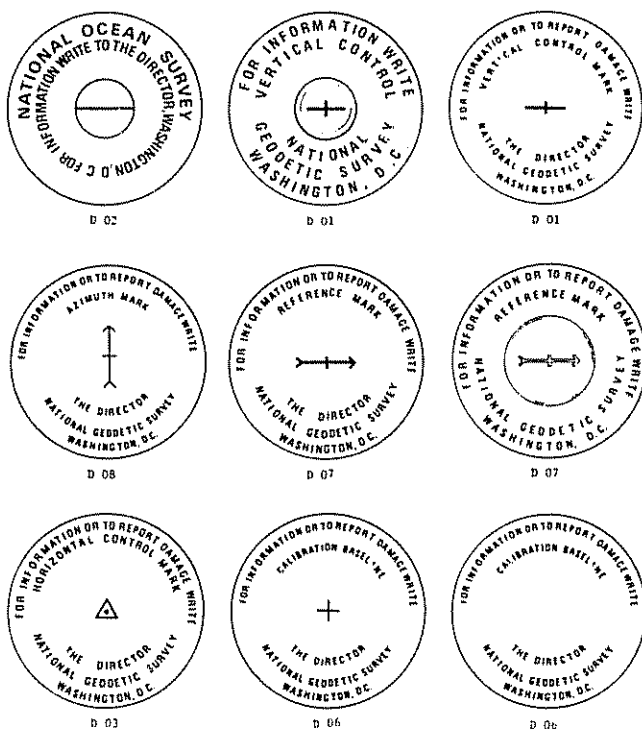

Figure 2-27.—Survey disks of the National Ocean Survey and National Geodetic Survey.

Select and describe reference objects carefully. Consider the available objects when selecting the site for a new mark. (See page 6 in the mark setting manual.) Keep in mind that a monument may have become obscured by brush or may be buried under dirt and gravel. The lines of position for at least two of the objects should intersect at nearly a right angle. Select objects that are well defined, permitting such precise measurements that extensive digging or clearing of brush is not required to recover the point. Avoid objects to which the distance must be estimated. A total of three objects, plus a witness post, are sufficient for most control points. When describing reference objects, indicate whether sizes are standard, approximate, or measured by observing the following conventions: A standard size is given in standard units, with a hyphen between the numeral and the unit; for example, "1-inch pipe" or "2- by 4-inch timber." An approximate size is given in metric units, prefaced by the word "about"; for example, "a walnut tree about 15 cm in diameter" or "a timber about 15 by 25 cm." A measured size is given in metric units; for example, "a post 10 cm in diameter."

Measure distances horizontally (not along the slope) to the nearest hundredth of a meter. After the metric distance, enter the distance to the nearest tenth of a foot in parentheses. If an object is more than 30.5 m (100 ft) from the point or is not definitive (such as the centerline of a highway), measure to the nearest tenth of a meter (integral foot). Precede estimated distances with the word "about."

Measure from the center of objects such as trees and telephone poles and perpendicular to objects such as fences and walls. Otherwise state the point from which the measurement was made. For example: "6.31 m (20.7 ft) north of the northeast corner of a semaphore base."

Be sure to describe the height of the mark relative to the ground or highway surface. A standard entry for this is available on line *42* of the description form. A similar standard entry for the measurement from a witness post is available on line *43*.

Enter additional notes as necessary to describe the monument or to explain unusual leveling procedures that may be required. Do not confuse culverts with bridges, piers with abutments, and retaining walls with foundations. Clarify information that may be somewhat misleading as presented in codes elsewhere in the description. For example, note the following: a mark which might be expected to bear a stamping but does not; a mark stamped with a designation duplicating that of another; a mark mounted vertically; the precise location of the control point on a large structure or an unusual monument; the presence of ferrous material in or adjacent to a monument; and the name of the owner on whose property the monument is set. Include your initials at the end of the text.

Throughout the text the following standard abbreviations may be entered for units of measurement: "m"

for meter, "mm" for millimeter, "cm" for centimeter, "km" for kilometer, "ft" for foot, and "mi" for mile. Unless undue confusion would result, avoid entering quarter-quadrant compass directions, such as east-southeast or north-northwest. Use the accepted terminology found in a dictionary or engineering textbook; avoid the use of jargon.

2.5 Relocating Vertical Control Points

Each vertical control point represents a large investment of resources. Since it is intended to provide a continuous record of elevation change, as well as control for many local surveyors, its preservation is vital to the maintenance of the national network. Although monuments are constructed in locations where they are unlikely to be disturbed, many are destroyed or damaged by highway widening and maintenance, bridge rebuilding, railroad maintenance, and building demolition and construction. Such deterioration of the network must be minimized.

Although regional mark maintenance engineers monitor the condition of the network, the areas they cover include many States. To preserve specific points, the cooperation of local engineers and surveyors is important. When recovering a mark, prepare a brief report of its condition (fig. 2-28). If a monument is about to be destroyed, notify NGS at once. Before it is destroyed, a vertical control point should be relocated as described here.

First, a new monument is constructed in the vicinity. Then the elevation difference is measured by leveling from the old to the new control point. Finally, the old monument is destroyed. Data are normally recorded on NOAA Form 76-60, "Report on relocation of bench mark." (See fig. 2-29.)

Setting a new monument. After NGS is given the designation and location of the monument about to be destroyed, the agency will send to the reporter a brass disk, which is prestamped with the designation and year of relocation. For example, the disk for M 346 is stamped "M 346 RESET 1980."

Select a site for the new control point, if possible within one leveling setup from the monument to be replaced. Construct a monument of the best possible quality in which the disk may be set. (See the instructions in 2.4.2 and in the mark setting manual.) Recommended settings for this purpose are a class B rod mark (with the disk crimped to the top), bedrock, or a large and stable structure. If a witness post is near the old monument, relocate it to the site of the new one.

Prepare a complete description of the new point, either on the report form or on a standard description form (NOAA Form 76-186). On the report form, be sure to include instructions to reach the point from the nearest city or town, construction details, and a position. If the position cannot be plotted and scaled as explained in section 2.4.3, note the 30' quadrant of Vertical Control Data and the number of the quadrant line in which the original point was described.

REPORT ON CONDITION OF SURVEY MARK

Form Approved
Budget Bureau No. 41-R1923

Name or Designation: U 150 Year Established: 1941

State: PA County: Huntingdon Organization Established by: C&GS

Distance and direction from nearest town: about 4.6 miles north along PA RR from station at Huntingdon

Description published in: (Line, book, or quadrangle number) Quad 400781

Mark searched for or recovered by: Name - Roger C. Poe
Organization - Michael Baker, Jr., Inc.

Date of report June 17, 1975 Address - P. O. Box 280, Beaver, PA 15009

Condition of marks: List letters and numbers found stamped in (not cast in) each mark.

| Mark stamped: | Condition: |
|---------------|------------|
| U 150 1941 | Good |
| | |
| | |

Marks accessible? Yes No Property owner contacted? Yes No

Please report on the thoroughness of the search in case a mark was not recovered, suggested changes in description, need for repairing or moving the mark, or other pertinent facts:

Witness Post? Yes ___ No X
Witness Post set ___ feet ___ of ___ mark.
Witness Post set ___ feet ___ of ___ mark.

If additional forms are needed, indicate number required. _____

Figure 2-28.—Report on the condition of a survey point.

Leveling to the new control point. Leveling should satisfy standards for second-order, class II accuracy or better. If the distance between the old and new points is greater than 140 m (460 ft), or if more than one setup is necessary, comply with the specifications for geodetic leveling given in chapter 3 of this manual. In most cases, however, leveling may be conducted as follows, with an engineer's level and a single rod. Be sure to record the type of instrument and the units of the rod scale (meters or feet). (See the example in fig. 2-29.)

1. Set up the instrument halfway between the old and new points, but no more than 70 m (230 ft) away from either point.
2. Plumb the leveling rod on the highest point of the old bench mark. Record the designation of the point. On the same line enter the published elevation.
3. Observe the intercept of the middle reticle line against the rod scale. Record the reading to the third decimal place. This completes the backsight, BS.
4. Compute the height of instrument, HI, which is the sum of the backsight and the elevation of the point. Record it on the same line.

5. Do not move the instrument. Plumb the rod on the highest point of the new bench mark. Record the designation of the point on the next line.
6. Again, observe the rod intercept. Record the reading on the same line as for step 5. This completes the foresight, FS.
7. Compute the elevation of the new point, which is the height of the instrument from the previous line minus the foresight. This completes the forward run.
8. Reset and relevel the instrument. Level backward, from the new point to the old, in the same manner as in steps 2 to 7. The elevation computed for the old point as the result of the backward leveling may differ from the published elevation by no more than ± 0.003 m (± 0.010 ft).
9. To compute the elevation difference from the old point to the new, subtract the mean of the two elevations for the old point from the elevation for the new point.

Destroying the old control point Do not destroy the old point until the leveling data have been checked. Remove the old disk and any other parts of the monu-

| | | | | | |
|---|-------|---|-------|-----------|-----------------------------------|
| NOAA FORM 76-60 (6-71) U. S. DEPARTMENT OF COMMERCE NATIONAL OCEANIC AND ATMOSPHERIC ADMINISTRATION REPORT ON RELOCATION OF BENCH MARK (See instructions on reverse side) | | DESIGNATION OF MARK <u>K 133</u> STATE COUNTY <u>NEW MEXICO LUNA</u> | | | |
| A. DESCRIPTION OF ORIGINAL MARK FROM THE SOUTHERN PACIFIC COMPANY RAILROAD STATION IN COLUMBUS, NORTH ALONG STATE HIGHWAY 11 FOR 4.6 KM (2.9 MI), 11.6 METERS (38 FEET) EAST OF THE CENTERLINE OF THE HIGHWAY, 19.5 METERS (64 FEET) WEST OF A ROW OF POLES, AND 0.34 METER (1.1 FOOT) EAST OF A WHITE WOODEN WITNESS POST. A STANDARD DISK SET IN TOP OF A CONCRETE POST PROJECTING 0.30 METER (1.0 FOOT) ABOVE GROUND. DESTROYED THIS DATE. | | | | | |
| PUBLISHED ON <u>N 321082 LINE 101</u> | | STAMPING <u>K 133 1934</u> | | | |
| B. WAS ORIGINAL BENCH MARK DESTROYED? <input checked="" type="checkbox"/> YES <input type="checkbox"/> NO HORIZONTAL CONTROL POINT? <input type="checkbox"/> YES <input checked="" type="checkbox"/> NO REMARKS INSTRUMENT: <u>NI 2 50132</u> ROD: <u>PHILADELPHIA, FOOT UNITS</u> DATE OF LEVELING <u>23 MARCH 1977</u> (Feet or Meters)* | | | | | |
| POINT | B.S. | H.I. | F.S. | ELEVATION | REMARKS |
| K 133 | 3.791 | 4182.759 | | 4178.968 | CLEAR, CALM, WARM |
| K 133 RESET 1977 | 5.177 | 4182.745 | 5.191 | 4177.568 | |
| | | | 3.789 | 4178.956 | .0127 .009 REJECTED |
| K 133 | 3.801 | 4182.769 | | 4178.968 | |
| K 133 RESET 1977 | 5.250 | 4182.820 | 5.199 | 4177.570 | 4177.570 |
| | | | 3.858 | 4178.962 | .006 MEAN = 4178.965 |
| | | | | | ELEVATION DIFFERENCE = - 1.395 FT |
| C. DESCRIPTION OF NEW MARK STAMPING ON NEW MARK <u>K 133 RESET 1977</u> FROM THE SOUTHERN PACIFIC COMPANY RAILROAD STATION AT COLUMBUS, NORTH ALONG STATE HIGHWAY 11 FOR 4.6 KM (2.9 MI). 30.1 METERS (99 FEET) EAST OF THE CENTERLINE OF THE HIGHWAY, 12.19 METERS (40.0 FEET) SOUTH OF MILEPOST 6.13, IN LINE WITH A ROW OF UTILITY POLES, AND 0.30 METER (1.0 FOOT) WEST OF THE HIGHWAY RIGHT-OF-WAY FENCE. A STANDARD DISK SET IN TOP OF A CONCRETE POST PROJECTING 0.30 METER (1.0 FOOT) ABOVE GROUND. | | | | | |
| *Strike out unit NOT used. | | SIGNED <u>NAME</u> PHONE <u> </u> AGENCY <u>NAME AND ADDRESS</u> | | | |

Figure 2-29.—Report of a relocated bench mark.

ment that bear a stamping (such as a logo flange or stainless steel cap on a rod) and return them to NGS.

Prepare a recovery note on the report form or a standard description form (NOAA Form 76-186), identifying and explaining the disposition of the old monument.

Submitting relocation records. To include relocation data in the national network, the following records must be forwarded to NGS:

1. Complete description of the new control point
2. Recovery note for the old control point.
3. Field records for at least two runs of leveling, one forward and one backward, including the computed elevation difference from the old to the new point.
4. Name, address, and telephone number of the individual who performed the relocation.

2.6 References

Dracup, J. F., 1976, rev. 1979: National Geodetic Survey data: availability, explanation, and application. *NOAA Technical Memorandum NOS NGS 5*, Na-

tional Geodetic Information Center, NOAA/NOS, Rockville, Md. 20852, 45 pp.

Floyd, R. P., 1978: Geodetic bench marks. *NOAA Manual NOS NGS 1*, National Geodetic Information Center, NOAA/NOS, Rockville, Md. 20852, 55 pp.

Gossett, F. R., 1959: Manual of geodetic triangulation, Coast and Geodetic Survey *Special Publication 247*. National Geodetic Information Center, NOAA/NOS, Rockville, Md. 20852, 352 pp.

Greenawalt, C. B. and Floyd, R. P., 1980: National Geodetic Survey Operations Manual (unpublished manuscript). NGS Operations Division, NOAA/NOS, Rockville, Md. 20852.

National Ocean Survey, published annually: *NOAA Tide Tables: High and Low Water Levels*. NOAA, National Ocean Survey, Rockville, Md. 20852.

Pfeifer, L. and Morrison, N. L., 1980: *Input Formats and Specifications of the National Geodetic Survey Data Base*, vol. II: Vertical control data. Federal Geodetic Control Committee. National Geodetic Information Center, NOAA/NOS, Rockville, Md. 20852, 136 pp.

Chapter 3

GEODETIC LEVELING

3.1 Introduction

In a widespread network of vertical control, geodetic leveling is the technique that provides the most reliable elevation differences between control points. It is a form of precise leveling where the observing team limits the magnitude of error by using calibrated instruments in combination with a rigorous, symmetrical observing procedure. In the following pages leveling procedures are described, the principal sources of error are discussed, and error tolerances are presented to provide a foundation for the instructions that comprise the rest of the chapter.

3.1.1 General Procedures

Along each line of a vertical control network, leveling is conducted in increments called sections. Each section is an unbroken series of setups, made between two permanent control points. A setup consists of a point supporting a backsight rod, a point supporting a foresight rod, and a leveling instrument positioned between them (fig. 3-1). Two heights are measured by sighting through the instrument toward a scale on each rod and recording the values intercepted by a line on the reticle. The height difference, backsight minus foresight, corresponds to the elevation difference between the two points. The foresight point of one setup becomes the backsight point of the next; thus, the sum of the elevation differences of the series of setups is the elevation difference for the section (fig. 3-2).

Three conditions must be satisfied for this technique to provide reliable elevation differences between points. First, the lines of sight from the instrument to the rods must be level; in other words, the lines of sight must be

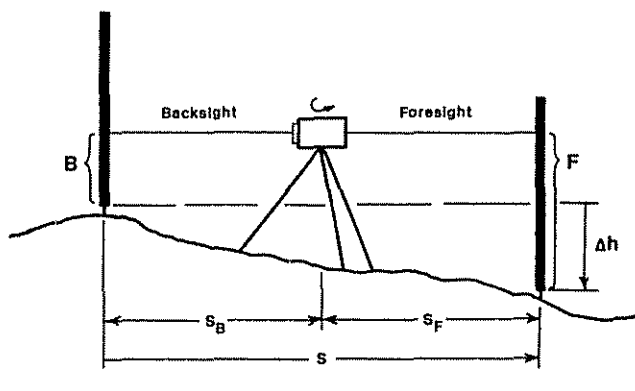

Figure 3-1.—Setup of leveling, $\Delta h = B - F$ and $s = s_B + s_F$

parallel at all times to the reference surface. Second, the values observed on the scales must accurately indicate heights above the points on which the rods rest, and third, the points in turn must be stable with respect to the topography.

These conditions cannot be perfectly satisfied in the “real world”; however, they may be approximated by limiting the known sources of error. Leveling is classified by the degree with which error magnitudes are limited. (See sec. 3.1.3, “Tolerances for geodetic leveling.”)

3.1.2 Sources of Error

Error may be characterized as random or systematic. Random error in leveling results represent the effect of unpredictable variations in the instruments, the environment, and the procedure of leveling. Random error cannot be completely eliminated, although it can be kept small. Therefore, it represents the “noise level,” the limit on the precision with which leveling may measure elevation differences.

Systematic error represents the effect of consistent inaccuracies in the instruments or in the leveling procedure. It also results from consistent, though not always predictable, environmental effects. Although systematic error may be small in a single measurement, it accumulates when measurements made under similar circumstances are totaled. Thus, it can result in a significant discrepancy in the elevation differences measured between two control points by different leveling systems and/or routes. For leveling to provide accurate elevation differences, systematic error must be eliminated, either by procedure or by applying corrections to the data.

The sources of error in leveling can be classified into three groups: those affecting the line of sight, those affecting the heights observed, and blunders. The line of sight cannot be exactly level because of the effects of imperfections in the instrument and variations in the human eye, refraction, curvature, and tidal accelerations. The heights observed are not exact because of imperfections in the rod scales and the turning points; furthermore, a perfectly stable relationship cannot be maintained between the equipment and the topography because of environmental effects on the equipment. Blunders may occur while attempting to limit any of these errors.

Leveling instrument. The instrument used for geodetic leveling should consistently provide a horizontal

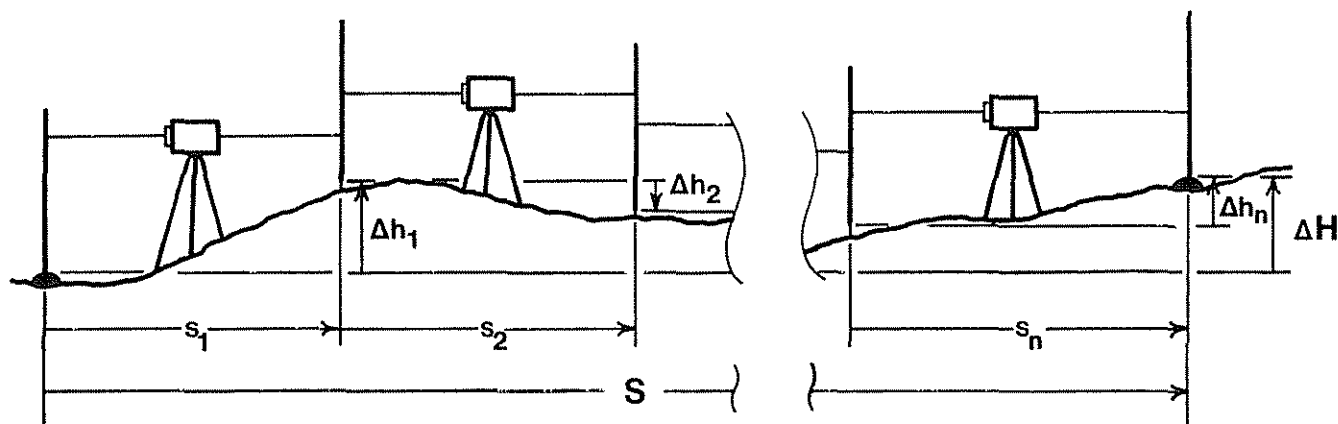

Figure 3-2.—Section of leveling, $\Delta H = \Delta h_1 + \Delta h_2 + \dots + \Delta h_n$ and $S = s_1 + s_2 + \dots + s_n$.

line of sight. The extent to which it achieves this determines its suitability for various orders and classes of leveling.

To be horizontal, the line of sight should be perpendicular to the direction of gravity, at the vertical axis of the instrument. If the line of sight is not horizontal, the angle by which it deviates from being horizontal causes an error in every observation (fig. 3-3). This angle is referred to as collimation error.

Collimation error can be limited by using a well-designed, properly maintained instrument. The angle should be measured and adjusted to specifications. The effect of collimation error on each observation can be reduced by limiting the sighting distance. Furthermore, if the sighting distances in each setup are balanced, the errors resulting from collimation error become equal. They cancel when the foresight is subtracted from the backsight to compute the elevation difference (fig. 3-4).

Although it is impractical to balance every setup exactly, the total contribution of collimation error can be limited very effectively while leveling by keeping the imbalance small and random in sign. Any systematic contribution that accumulates with distance may be

eliminated by later applying corrections computed from the imbalance and a precisely determined value for the collimation error.

Collimation error should not change as the instrument is refocused or rotated about its vertical axis. A consistent difference between the collimation errors of the backsight and foresight causes a systematic accumulation of error (fig. 3-5). The precautions described here will limit this effect, but, because it is unpredictable, it cannot be eliminated. Additional precautions should be taken to ensure that a consistent difference does not exist.

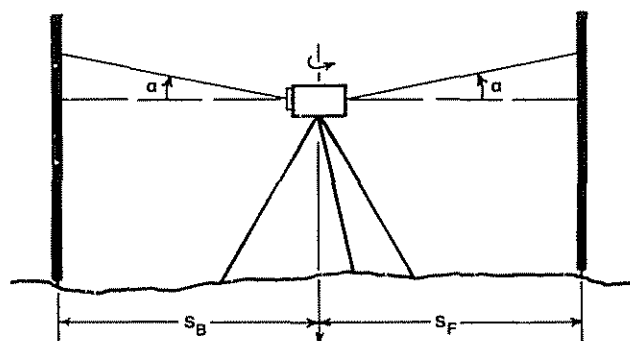

Figure 3-4.—Consistent collimation error cancels in a balanced setup since $s_B = s_F$.

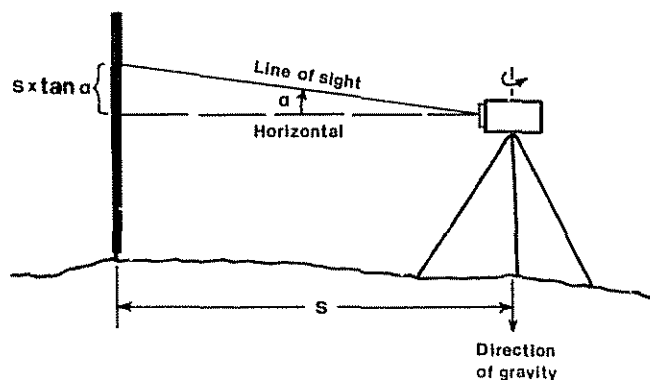

Figure 3-3.—Effect of collimation error, α .

In a compensator-type leveling instrument such a difference can occur if the compensator is not suspended properly in each direction. To prevent gross error the spherical level on the instrument should be properly adjusted, and compensation checks should be performed routinely. To eliminate smaller systematic effects, the compensator should be repositioned during each setup.

In a spirit-level type of leveling instrument, the error caused by imprecision in centering can become systematic if the bubble is consistently affected by a heat source in one direction. Shading the instrument should reduce this effect.

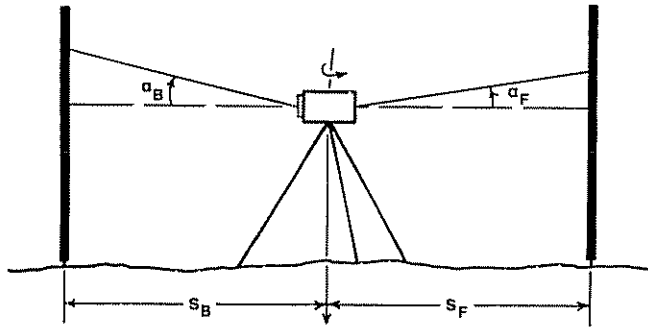

Figure 3-5.—Inconsistent collimation error does not cancel in a balanced setup since $\alpha_B \neq \alpha_F$, even if $s_B = s_F$.

Pointing. Another effect on the line of sight results from the human inability to repeat a pointing exactly. Both imperfections in the instrument and atmospheric refraction may contribute to this effect, combining with the imperfection of the human eye, to create pointing error.

The magnitude of pointing error is reduced by the use of a precise instrument with a micrometer and wedge reticle that has been adjusted to remove parallax. Limiting the sighting distance and instrument movement can also reduce the magnitude of the error.

Refraction Variations in atmospheric density cause the line of sight to refract or bend in the direction of increasing air density. These variations seem to be primarily a function of air temperature.

Refraction is most noticeable when the line of sight passes through air of fluctuating density, as when "heat waves" are observed. The graduations on the scales appear to move up and down rapidly. This phenomenon, called shimmer (fig. 3-6), makes it difficult to intercept the scales precisely, thus increasing the magnitude of pointing error. It can be reduced by shortening the sighting distances or, in some cases, raising the height of the line of sight.

Whether or not shimmer is observed, the line of sight may be refracted. Since the error caused by refraction increases proportionately with the square of the sighting distance, refraction error may be reduced by limiting the sighting distance. As long as atmospheric conditions are similar along both the foresight and backsight, the error may be nearly eliminated by balancing setups.

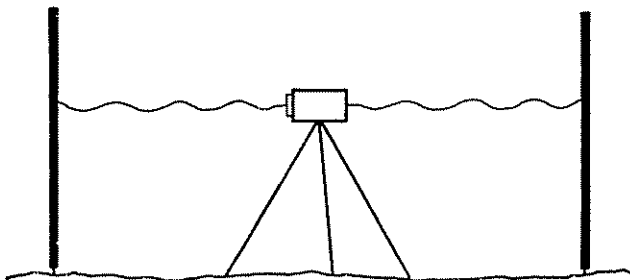

Figure 3-6.—Shimmer.

However, conditions are often not the same along both lines of sight. Air close to the ground changes in density more rapidly than air situated 1 m or more above ground. This can be visualized by imagining air layers, of equal density, conforming to the topography. On a slope, even if setups are exactly balanced, the conditions along the foresight differ from those along the backsight (fig. 3-7). Because the sight uphill passes through a greater change in air density, it is refracted more. Refraction error, then, accumulates with change in elevation.

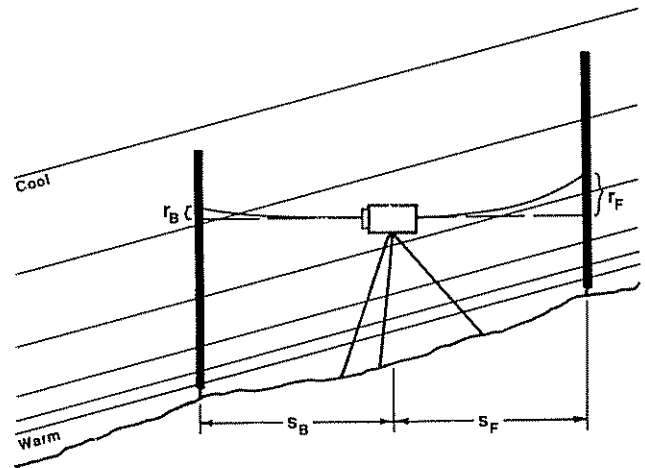

Figure 3-7.—Refraction error, r , does not cancel on sloping terrain since $r_B \neq r_F$, even if $s_B = s_F$.

Leveling results may be corrected at least partially for refraction if atmospheric conditions are determined and recorded with the observations. Of the many mathematical models that attempt to predict refraction error, the most successful require that air-temperature differences be precisely measured during every setup.

Two types of refraction error cannot be corrected. Therefore, the situations which cause them should be avoided when leveling. If the line of sight passes very close to the ground or to an intervening object, changes in air density cause the line of sight to be refracted in an unpredictable way. Similarly, when the air near the ground is cooler than the air above it, the relatively stable air layers may move slowly across the line of sight, causing long-period shimmer. The graduations on the scales appear to move up and down, but so slowly that an entire setup may be observed and checked before the movement is noticed. The observations may be significantly and unpredictably affected by the unnoticed shimmer. This effect usually occurs at night when the air is calm.

Curvature. Both the leveling instrument and the rods are oriented to the direction of gravity, to measure elevation differences with respect to the same reference surface. When the instrument is level and is rotated so

that the line of sight intercepts each scale, the line of sight should sweep out a horizontal plane. It would be parallel to the equipotential surface if the gravity field, at each setup, also defined a plane. This is not the case, however, since the gravity field defines a curved surface. Thus, a small amount of curvature error is introduced into each observation (fig. 3-8).

Curvature error is proportional to the square of the sighting distance. Assuming the equipotential surface is evenly curved, curvature error can be reduced by making the backsight and foresight distances in each setup nearly equal. If setups are thus balanced, within a tolerance, correction for curvature need not normally be made while leveling.

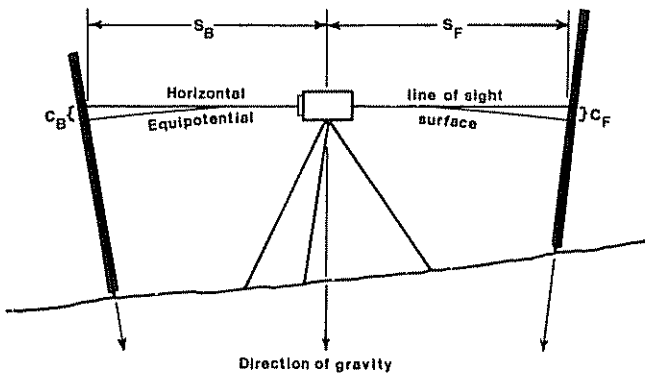

Figure 3-8.—Curvature error, c , where the line of sight is not parallel to an equipotential surface, cancels if $s_B = s_F$.

Because the surfaces defined by the gravity field are not evenly curved, minute differences in curvature error in every setup accumulate systematically in leveling conducted over large changes of elevation, particularly in a northerly or southerly direction. Even so, the magnitude of this error is so small that it may be neglected if the backsight and foresight distances are nearly equal.

Tidal accelerations. Because leveling instruments and rods are oriented to the direction of gravity, after curvature has been taken into account, the elevation difference of each section is computed along a route that approximately parallels an equipotential surface. However, the Sun and Moon create tidal accelerations that periodically distort this surface, generally more toward the equator than the poles (fig. 3-9).

The distortion is termed a deflection and is described by two component vectors. The vertical component affects only the magnitude of gravity along the route, resulting in a negligible effect on the elevation difference. The horizontal component, however, acts at 90° to the equipotential surface, resulting in a small error, especially if the section is oriented in a line with the Sun, Moon, and the north or south pole. The error accumulates significantly in leveling lines oriented north-south, particularly in the middle latitudes. To remove it, a correction must be applied.

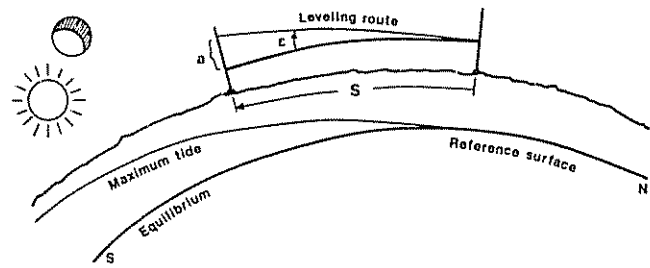

Figure 3-9.—Effect, a , of tidal deflection, ϵ , on a section of length and direction, \bar{S} .

Leveling rods. To observe accurate heights above the points on which the leveling rods rest, precise relationships must be maintained between the rods and the equipotential surface, and between the rods and the scales mounted on or within them.

The first relationship is ensured by plumbing, or aligning the rods with the direction of gravity, a task which is analogous to leveling the instrument. If they are not so aligned, an error is introduced into each observation. Although the error may be small, it accumulates systematically with change of elevation, especially on steep slopes where observations are made alternately low and high on the scale. (See figs. 3-10, 3-11, 3-12.) It can be limited only by plumbing the scales properly.

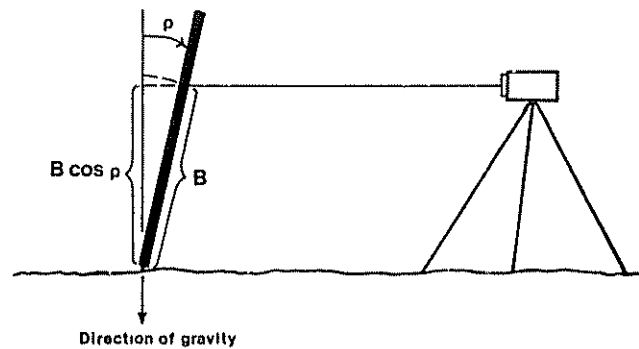

Figure 3-10.—Effect of rod plumbing error, ρ , on a height observation, B .

The second relationship depends upon the accuracy with which the scales are manufactured and mounted in or on the rods. If the graduations are not accurately marked above the scale zero or if the scale changes in length during leveling, error may accumulate in the observations. To limit the error, leveling rods should be well-designed, routinely calibrated, and properly handled and maintained.

The index error, which is the difference in height from the scale zero to the base plate of the rod, represents a constant portion of the error in the scale values. Index error can be eliminated by making an even number of setups for every section, thus using the same rod on

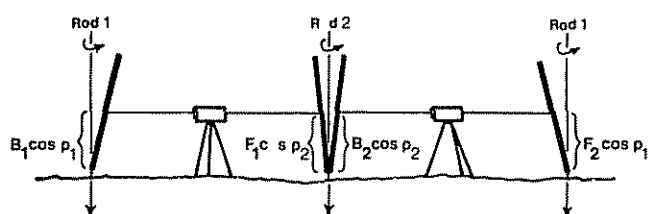

Figure 3-11.—Systematic effect of plumbing error (and scale errors) is small on flat terrain, since $B_1 \approx F_2$ and $F_1 \approx B_2$.

every bench mark during the leveling. (It can also be eliminated if only one rod is used if accurate calibration corrections are applied.)

In much the same way as an error in plumbing, error in the scale values causes systematic error to accumulate with change of elevation. For the most accurate results, observed scale values should be corrected to standardize them with respect to the National Standard of Length. To do this the rods must be accurately calibrated. Since the scales are subject to thermal expansion, the coefficient of thermal expansion must also be measured, and scale temperatures should be recorded during the leveling.

Turning points. The leveling rods must be set on clearly defined, stable points. Rather than using natural objects, which may or may not prove to be adequate, portable, standardized turning points should be used. They should provide definite points on which to rest the rods. Both the base plate of a rod and the top of a turning point should be cleaned before placing the rod on the point.

To prevent error when leveling to and from control points, they too should provide definite points. Since this is not always possible, special procedures may be necessary for leveling to awkward points.

Stability. During each setup, the leveling instrument and the rods may change elevation because of settlement or rebound caused by the type of ground cover. To minimize error from such movement, the backsight and foresight should be observed nearly simultaneous-

ly. This requires two rods and an efficient instrument and leveling unit.

Instrument movement can be reduced by proper use and maintenance of the tripod. Systematic error resulting from consistent movement of the instrument can be eliminated by using one of two observing procedures. In one procedure, known as micrometer leveling, two elevation differences are measured in two directions during each setup. If the instrument settles significantly during either or both measurements, the observations will not lie within a limit imposed on the difference between the results. Averaging the results practically eliminates any remaining systematic error.

In the other procedure, three-wire leveling, the first reading of the setup is made on the backsight of odd-numbered setups, and on the foresight of even-numbered setups. Consistent settlement of the leveling instrument will cause the results of odd setups to be too large and the results of even setups to be too small by a similar amount. Thus, over a section with an even number of setups, the errors nearly cancel.

Rod movement is minimized by placing the turning points so they provide sufficient stability. Systematic error caused by consistent movement during each setup can be limited somewhat by the procedures described previously. If the rods are allowed to rest on the points for 20 seconds before making an observation, any remaining movement should be negligible.

When proceeding from one setup to the next, the forward turning point must not move. This can only be assured by the rodman's diligence and by comparing repeated levelings of the section. Averaging the results of two runnings, made in opposite directions, nearly eliminates any systematic accumulation of error resulting from consistent movement.

Blunders. Errors that result from failure to follow the specified procedures are termed blunders. In leveling, no unit is so experienced that the work performed by the group can be automatically considered free of blunders. Only conscientious attention to detail, combined with scrupulous checks and cross-checks, can ensure accuracy.

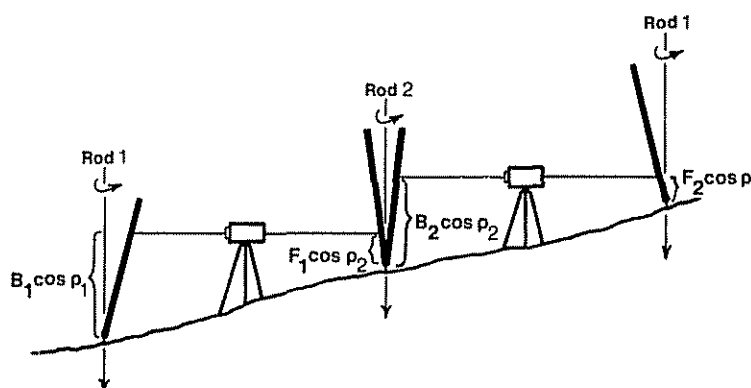

Figure 3-12.—Effect of plumbing error (and scale errors) accumulates on sloping terrain, since $B_1 \neq F_2$ and $F_1 \neq B_2$.

Random blunders are usually large and occur at single setups. They include (1) mistakes in reading or recording scale values, (2) observing the rods in the wrong order, (3) improper placement or leveling of the instrument, (4) gross movement of the instrument or turning points during the setups, (5) improper placement or plumbing of the rods, and (6) gross movement of the forward point between setups. The first four of these blunders may be detected and eliminated with confidence by using double-scale rods, computer-recording equipment, and the micrometer-leveling procedure given in section 3.7.2. In this system, observations are made in such a way that checks for internal consistency can be computed. The last two blunders, if unreported by the responsible rodman, may be detected only by comparing repeated levelings of the section.

Systematic blunders are more difficult to detect. They are primarily caused by failure to follow the procedures necessary for precise leveling, particularly maintenance of the instrument and the rods. If the collimation check and the compensation check are not performed correctly, the use of an improperly adjusted instrument may introduce error, undetectable in each setup, but accumulating over the line. Similarly, if the spherical levels on the rods are not properly adjusted, error may accumulate. If a rod is dropped, or otherwise damaged, previous calibration values may no longer apply and the data cannot be corrected with confidence.

3.1.3 Tolerances for Geodetic Leveling

To produce reliable elevations, the results of geodetic leveling must satisfy the appropriate standard of accuracy for the order and class of a survey. This standard is attained in three ways while leveling: first, by operating a well-organized and well-trained leveling unit; second, by selecting sufficiently precise equipment and calibrating it properly; and third, by adopting observing and recording routines that limit accumulation of error. Specific instructions for satisfying these requirements are presented in the remaining sections of this chapter. Tolerances, suitable for attaining each standard of accuracy, are presented in table 3-1.

Two types of tolerances must be applied. The first type is a set of practical limits on the dimensional factors within the leveling system that are known to increase the magnitude of error in the results. The second type is a set of limits on the precision of the results obtained from two or more levelings between the same two points. The tolerances should reflect the probable magnitude of random error that cannot be corrected or eliminated. Then, blunders and most systematic error can be detected and removed from the leveling data.

The second set of tolerances is defined with the expectation that the tolerances will be exceeded 5 percent of the time (95 percent test level). This permits a check

on the validity of the limits imposed. If leveling results exceed the limits more than 5 percent of the time, either the first set of tolerances is not being satisfied or the second set has been made too restrictive (forcing observations that may not be accurate to appear precise). If leveling results exceed the limits less than 5 percent of the time, the second set of tolerances may not be restrictive enough.

Tolerances, revised periodically by the Federal Geodetic Control Committee, are published in *Classification, Standards of Accuracy, and General Specifications of Geodetic Control Surveys* (Federal Geodetic Control Committee 1974) and *Specifications to Support Classification, Standards of Accuracy, and General Specifications of Geodetic Control Surveys* (Federal Geodetic Control Committee 1980).

3.2 Organizing a Leveling Unit

During a leveling project one or more units operate under the supervision of a project director who supports and monitors the activities. Like mark setting units, each leveling unit must be capable of working self-sufficiently several hundred kilometers from the project office. Guidelines are presented here for organizing and maintaining such units.

3.2.1 Personnel

A leveling unit normally requires five persons: the observer, the recorder, two rodmen, and a pacer. Certain equipment or conditions may require that additional personnel be assigned. An experienced unit, equipped with a compensator-type leveling instrument and special vehicles, can operate efficiently with four persons.

The leveling unit is exactly what the name implies, a unit, and each person in the group, whatever the position, must be constantly on the alert to ensure that all duties are performed promptly and carefully. Complete and continuous attention to the details of the work is required of all members of a unit if it is to operate smoothly and efficiently. Any member of the unit who is slow, careless, or indifferent can ruin the work of the whole unit.

Unit chief. The unit chief, who usually serves as the observer, is responsible for managing the unit in the field. The quality and quantity of leveling produced depends on the experience and good judgment of the chief. Practical proficiency in each of the leveling duties is a prerequisite for the job. This individual should set an example which ensures correct, safe, and efficient leveling.

The chief should ensure that the specifications and guidelines contained in this chapter are strictly followed by all unit members. New employees, in particular, should be thoroughly instructed in their duties. The chief should ensure that project instructions are read

Table 3-1.—Tolerances for geodetic leveling

| | First order class I | First order class II | Second order class I | Second order class II | Third order |
|--|--------------------------------|-------------------------|-------------------------|--------------------------|-------------|
| Lines of sight | | | | | |
| Maximum sighting distance | 50 0 m | 60 0 m | 60 0 m | 70 0 m | 90 0 m |
| Maximum imbalance. | | | | | |
| per setup | ± 2 0 m | ± 5 0 m | ± 5 0 m | ± 10 0 m | ± 10 0 m |
| per section | ± 4 0 m | ± 10 0 m | ± 10 0 m | ± 10 0 m | ± 10 0 m |
| Leveling instrument | | | | | |
| Maximum collimation error. | | | | | |
| single line of sight | ← ± 10'' 0 (C ≤ ± 0 05 mm/m) → | | | | — — |
| mean of two lines of sight | ← ± 4'' 0 (C ≤ ± 0 02 mm/m) → | | | | — — |
| Maximum angular difference in two lines of sight | ← ± 40'' 0 (Q ≤ ± 0 20 mm/m) → | | | | — — |
| Setting precision | ± 0'' 25 | ± 0 25 | ± 0'' 50 | ± 0'' 50 | — — |
| Minimum reading | ± 0 1 mm | ± 0 1 mm | ± 0 5 mm | ± 0 5 mm | — — |
| | Micrometer required | Micrometer required | | | |
| Leveling rod | | | | | |
| Plumbing accuracy | ± 10 '0 | ± 10 '0 | ± 10 '0 | ± 10 '0 | |
| Maximum scale unit | 1 0 cm | 1 0 cm | 1 0 cm | 1 0 cm | |
| Calibration accuracy | ± 0 05 mm | ± 0 05 mm | ± 0 05 mm | ± 0 05 mm | |
| Agreement of observed elevation differences before correction, observed backward and forward during | | | | | |
| One-setup section | ± 0 40 mm | ± 1 00 mm | — — | — — | — — |
| Two runnings of a section less than 0 10 km in length | ± 0 95 mm | ± 1 26 mm | ± 1 90 mm | ± 2 53 mm | ± 3 79 mm |
| Two runnings of a section of one- way length K : $T \times \sqrt{K}$ mm, $T =$ | ± 3 00 | ± 4 00 | ± 6 00 | ± 8 00 | ± 12 00 |
| Three or more runnings of a section: Each accepted running must differ from the mean of all accepted runnings by no more than $t \times \sqrt{K}$ mm. t given below For a section less than 0 10 km in length, let $K = 0 10$ | | | | | |
| Number of levelings: | | | | | |
| 3 | 2 10 | 2 81 | 4 21 | 5 63 | 8 44 |
| 4 | 2 33 | 3 10 | 4 66 | 6 23 | 9 34 |
| 5 | 2 48 | 3 31 | 4 96 | 6 64 | 9 95 |
| 6 | 2 59 | 3 46 | 5 19 | 6 94 | 10 4 |
| 7 | 2 68 | 3 58 | 5 36 | 7 18 | 10 7 |
| 8 | 2 75 | 3 67 | 5 51 | 7 37 | 11 0 |
| One leveling of a loop of one-way length K , beginning and ending at the same point: $T \times \sqrt{K}$ mm. $T =$ | | | | | |
| | ± 4 00 | ± 5 00 | ± 6 00 | ± 8 00 | ± 12 00 |

and understood by unit personnel, resolving any technical questions before work begins. When substantial confusion or doubt about a field procedure exists, the chief should seek immediate guidance from the project director.

In addition to technical concerns, the chief is responsible for the safety of personnel, and for the security and maintenance of all equipment assigned to the unit. Any deficiencies in these areas must be reported immediately to the project office. The chief submits weekly and monthly status reports, and is also charged with the safekeeping of the leveling data until they are properly transmitted to the project office.

The chief can improve the unit's efficiency by planning each day's activity in advance. By reviewing the logs in advance of the surveying date, sections which require unusual survey procedures can be pinpointed and the project director notified if any additional personnel or equipment are needed. It is helpful each morning to explain the day's goals to the unit. Whenever possible, duties should be rotated to provide opportunities for unit members to develop and upgrade their skills. When weather conditions or other factors prevent leveling, the chief should assign unit members other duties such as maintaining equipment or augmenting their skills and knowledge.

Observer. The unit chief or another individual who serves as the observer should have a thorough understanding of the leveling instrument, as well as the experience to operate it correctly and efficiently. The observer is responsible for maintaining the instrument and the tripod, and should follow the precautions outlined in subchapters 3.3, "Leveling instruments," and 3.6, "Atmospheric conditions." He or she should be constantly alert, to ensure that the route for the line is followed correctly, to plan ahead to avoid problematical setups, and to monitor the activities of the rodmen. The observer should check the recorder's work periodically and check and initial all records at the conclusion of each day's work.

Recorder. The recorder enters observation data on recording forms or into a portable computer. He or she should write legibly and be able to follow exactly the recording procedures outlined in subchapters 3.7, "Observing routine," and 3.8, "Field records." A clear understanding of the mathematical computations and checks is important, whether recording on a form or a computer, and the ability to compute these checks rapidly is essential when using recording forms. When using a computer-recording system, the recorder should be familiar with the various recording programs and skilled in operating and maintaining the equipment.

The recorder should be an alert and conscientious driver, since the truck that transports the rodmen and observer from setup to setup can be used as a recording station. In addition, the recorder should support the observer by checking constantly for blunders or oversights, which would lower the quality of the leveling, and by serving as acting observer in the absence of the unit chief.

Rodman. Although the position is often filled by an individual with little surveying experience, the rodman's duties are critical to precise leveling. With a computer-recording system, observing and recording blunders may be discovered and corrected before leaving each setup; however, no check can be made as to whether or not a turning point or leveling rod has moved between setups unless the entire section is releveled. The turning point and the leveling rod are the responsibility of the rodman.

He or she should be unquestionably reliable and conscientious, able to pace precisely, adept at handling the rod, and meticulous in setting turning points, following the precautions described in subchapters 3.4, "Leveling rods," and 3.5, "Turning points." The rodman is charged with the responsibility of maintaining the equipment properly and reporting deficiencies promptly. When a mistake is made (e.g., pulling a turning pin too soon or accidentally bumping a turning plate), the rodman should report it immediately. For motorized leveling, the rodman must be able to operate skillfully a specially equipped motorcycle or small vehicle, and perform minor maintenance.

Pacer. The pacer, an optional position which is usually rotated with the position of the rodman, marks out precisely balanced setups and sets the turning points ahead of the unit. He or she should be able to select a satisfactory leveling route, based on the information provided in the logs. The pacer also sets up warning signs and returns for the leveling truck after sections have been walked. In motorized leveling, this position is not necessary if the vehicles are equipped with accurate odometers.

Other personnel. A spirit-level instrument must be shaded during leveling, thus creating the need for a person to hold an umbrella. In three-wire leveling, this person assists the recorder by making the back check. (See sec 3.7.4). He or she may also be needed to shield the instrument in extremely windy conditions.

If a traffic lane must be closed, two flagmen are required to divert traffic. These are usually the pacer and a sixth person who is temporarily assigned to the unit.

3.2.2 Equipment

Survey equipment, itemized in appendix B, should be readily available and routinely maintained by the personnel in the unit. An inventory should be conducted when the equipment is issued to the unit chief and at least once a year thereafter. All equipment should be stored securely, in an organized fashion, in the leveling truck or other assigned vehicles.

Items of survey equipment have been classified and coded according to type. The codes must be recorded together with the serial numbers of equipment used to collect data that are to be included in the national network. The codes are listed in *Input Formats and Specification of the National Geodetic Survey Data Base* (Pfeifer and Morrison 1980: vol II, annex F).

In general, the individual who uses a piece of equipment should be responsible for its maintenance. Any defective or damaged equipment should be reported immediately to the project director. When the unit is working at a substantial distance from the project office, a spare leveling instrument should be available, especially if the instrument's collimation error cannot be adjusted in the field.

When equipment requires maintenance that cannot be performed by the leveling unit, the equipment should be returned to the project office. If the equipment cannot be delivered in person, it should be packaged properly to prevent damage in shipment. Instruments and computer-recording equipment are particularly vulnerable to such damage.

Motorized leveling. The term "motorized leveling" refers to using vehicles to transport all members of the leveling unit from one setup to the next. When personnel proceed between setups, they must usually wait for the

backsight rodman, who has twice the distance to travel. Traditionally, the leveling truck, driven by the recorder, transports the rodmen half this distance to reduce the cycling time of each setup. When the rodmen are equipped with vehicles, the cycling time can be further reduced, especially if each vehicle is provided with a mechanism for setting the turning point and raising and lowering the rod without leaving the vehicle.

A specialized observing vehicle driven by the recorder may allow the observer to set up and level the instrument more efficiently, perhaps at a height sufficient to reduce the effect of refraction. A built-in intercom can prevent misunderstandings between the observer and the recorder. In addition, both the instrument and personnel are protected from the weather, permitting leveling to continue under a wider variety of conditions.

In the traditional, partially motorized routine, the backsight rodman proceeds to the leveling truck and rides to the instrument position of the next setup. From there the rodman proceeds to the foresight position, at which the pacer should already have placed a turning point. When only four persons are available, the rodmen must pace to and set their own points.

Vehicles, equipped with precise odometers, may improve the rodmen's efficiency. In the absence of a pacer, however, the rodmen must still set their own turning points.

3.2.3 Safety

Because lines of leveling typically follow highway and railroad right-of-ways, personnel must be alert at all times to the hazards of working close to traffic.

When operating along a road, each member of the unit must wear a highly visible, orange vest. Work should be conducted as far from the road itself as possible, avoiding setups which unnecessarily expose personnel to the traffic. For added protection, warning signs should be placed within 1.6 km of the unit, in each direction. Any other safety requirements should be identified at the time liaison with the State highway district office is established.

Any vehicles used to transport the rodmen and the observer during a section of leveling should be driven on the right shoulder of the road, oriented with the flow of traffic. Vehicles should never be backed against traffic. A warning light should be flashing and the vehicle's hazard lights should be turned on. If the road shoulder is too narrow or if the highway is too heavily traveled to accommodate the leveling truck or other vehicles, the section should be walked. If there is insufficient room for the unit to pass safely on foot, the procedures cited under "Controlling traffic" (next subheading) should be used.

When working along a railroad, do not wear orange vests or use flashing lights, since these may cause a train to stop unnecessarily. Each person should be alert to

the presence of approaching trains and be ready to warn other unit members. Each person should also have an escape route planned, especially when working on terrain where a train is not visible until the last instant.

All personnel in the unit should be trained in basic first aid and cardiopulmonary resuscitation. At each work area they must be aware of the location and telephone number of the nearest emergency medical-treatment center, so prompt assistance can be obtained if an accident occurs. Any personal injury must be reported to the project director immediately. More detailed guidelines for safety are given in the National Geodetic Survey Operations Manual (Greenawalt and Floyd 1980).

Controlling traffic. When a traffic lane must be closed, as when leveling across a bridge with no sidewalks or leveling through a tunnel, permission to control the traffic must be obtained from local authorities. A suitable configuration for controlling traffic is shown in figure 3-13. Six personnel are necessary: two flagmen and a four-person leveling unit. The flagmen must be equipped with portable radios to coordinate their efforts. The recorder should drive the truck as for routine leveling. When added protection is necessary, two extra vehicles, each driven by an additional person, should precede and follow the unit.

After setting up warning signs, the unit proceeds down the right lane, as shown in figure 3-13. The forward flagman moves about one setup ahead of the unit, stopping traffic in the left lane (example 1). The rear flagman stops traffic behind the unit. After notification by radio that traffic in the left lane is stopped, the rear flagman begins directing traffic around the unit. When the setup is complete, the unit waits until the rear flagman has stopped traffic in the right lane (example 2). After notification of this, the forward flagman allows traffic to proceed in the left lane, and advances one setup ahead of the next setup. The unit advances at the same time to establish the next setup (example 3).

3.2.4 Reports

The project director should visit each unit at least once each month to inspect technical and safety procedures, and to provide personnel with updated information on project accomplishments. At all other times the unit chief should maintain regular communication with the project director. This can be accomplished in person when the unit is operating near the project office and by telephone when the unit is at a distant location. In addition, the reports described in the following paragraphs are required of the level unit.

Weekly leveling report. The weekly status report is submitted in person or mailed to the field office at the end of work each week. Any certified or registered-mail receipts for leveling data sent to the project office during the week should accompany the report. The report

With two vehicles:

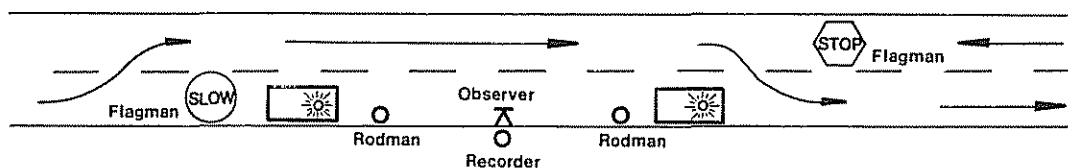

With one vehicle:

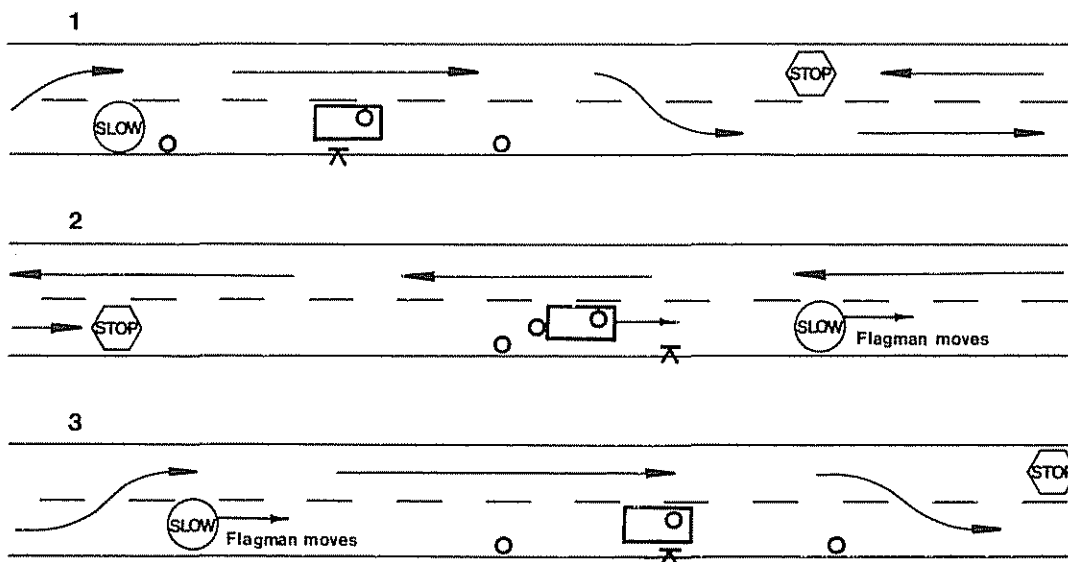

Figure 3-13.—Controlling traffic.

includes notes on progress, weather, activities, equipment condition and maintenance, suggestions, and requests for supplies. Figure 3-14 shows a properly executed NOAA Form 76-159.

When completing the form, enter distance in kilometers to one decimal place. Of primary interest is progress—the amount of the assigned line which has been completed. Report progress in two categories: double run and single run. Double-run progress is the total one-way distance of all sections that have been leveled in both the forward and backward directions. Single-run progress is the total one-way distance of all sections that have been leveled in only one direction.

When a section is relevelled in the same direction as an earlier leveling, total the distance as rerun. For example, if a double-run section fails to close, count the distance for the third leveling of the section as the first rerun. If still more levelings are required to obtain closure, count the distances in the column for additional reruns.

The total distance represents the amount of work performed by the unit each day. It is the total of all the leveling distances, including both directions of double-run sections and all reruns. Check the statistic totals each day by this formula:

$$(2 \times \text{double-run progress}) + \text{single-run progress} \\ + \text{rerun} = \text{total.}$$

The formula may be used to calculate double-run progress each day when an entire line is double run. Total the distance for the day, subtract all reruns, and divide what remains by two.

Report the number of setups of leveling completed each day. Do not count setups from the collimation check and setups from incomplete sections. Also report the number of section runnings completed.

The time at which the first setup began and the time when the last setup ended should correspond with the beginning and ending times recorded in the leveling data. Any delays of 15 minutes or more during the work-day should be noted and explained in the remarks.

Note the number of collimation and compensation checks made. Also note the number of persons working with the unit for the day. Columns for weather conditions and remarks should be completed. Note such items as: cloud cover, wind speed, temperature, unusual climatic conditions, change of lines, change of observer, change of unit personnel, plumbing of rods, other adjustment and maintenance activities, equipment breakdowns, accidents, training activities, and any incidents which have a bearing on the quality of the leveling or condition of personnel and equipment.

Monthly leveling report. The monthly leveling report is submitted, either by mail or in person, to the project

office at the end of work on the last day of each month. The report contains the same information as that given in the weekly report. Unlike the weekly report, however, the monthly report is forwarded to the headquarters of the National Geodetic Survey, where it serves as a source of statistical information and suggestions concerning the progress of leveling in the national network.

Figure 3-15 shows a properly executed monthly releveling report. At the end of each work day, the unit chief should fill out the line on the report corresponding to that day's activities. Then it is a simple matter to complete the totals at the end of the month.

Vehicle report. Careful records should be kept of all expenses incurred for the repair and maintenance of the leveling truck and other vehicles. A report summarizing these expenses should be submitted, together with all pertinent receipts, to the project office at the end of each month.

Miscellaneous reports. The unit chief should be familiar with current organizational procedures for submitting per diem vouchers, accident reports, personnel reports, and expense receipts.

3.3 Leveling Instruments

The instrument used for geodetic leveling must be precisely manufactured to ensure both sensitivity and ruggedness. This subchapter describes the mechanisms that are important in an optical instrument that is suitable for geodetic leveling. Specifications are included for proper maintenance and use of the instrument.

3.3.1 Classification

Optical leveling instruments are classified in two ways. The first is by the mechanism with which they provide a horizontal line of sight. Spirit-level instruments depend on a sensitive tubular level attached to the telescope. A fine-pitch tilting screw is turned manually to center the bubble in the vial of the spirit level. Compensator instruments depend on a pendulous reflecting component, the compensator, within the optical system of the telescope. Responding to the attraction of gravity automatically renders the line of sight horizontal.

Since the line of sight provided by either type of instrument cannot be exactly horizontal, the resulting collimation error must be regularly measured and ad-

| FORM 76-159 (3-62) | | | | | | | | | | | U.S. DEPARTMENT OF COMMERCE NATIONAL OCEANIC AND ATMOSPHERIC ADMINISTRATION | | |
|--|---------------|--------------|------------|------------|-------------|--------------------------------------|-----------|-------------|-------------|---------------------------------|--|---|--|
| WEEKLY REPORT - LEVELING UNIT | | | | | | | | | | | | | |
| OBSERVER <i>C. Smith</i> | | | | | | RECORDER <i>M. Cyr, M. Drenth</i> | | | | MONTH/YEAR <i>July 19 82</i> | | | |
| RODMEN, PACER <i>J. Sparks, M. Cyr, M. Drenth</i> | | | | | | PARTY <i>G-36</i> | | | | | | | |
| LOCATION(S) <i>Cle Elum, Wa.; Wenatchee, Wa.</i> | | | | | | PROJECT <i>83624100</i> | | | | | | | |
| LINE(S) <i>279</i> | | | | | | SURVEY ORDER <i>First</i> | | | | CLASS <i>II</i> | | | |
| DAY | DISTANCE (km) | | | | | NUMBER | | TIME | | COLL AND COMP CKS | STAFF DAY | WEATHER CONDITIONS | REMARKS |
| | OBL RUN PROG | SGL RUN PROG | 1ST RE-RUN | ADL RE-RUN | TOT ALL RUN | SET UPS | SECTION | 1ST SET UP | LAST SET UP | | | | |
| Sun 4 | | | | | | | | | | | | | |
| Mon 5 | | | | | | | | | | | | | <i>Holiday (4th of July)</i> |
| Tue 6 | | <i>8.4</i> | | | <i>8.4</i> | <i>125</i> | <i>9</i> | <i>0821</i> | <i>1620</i> | | <i>4</i> | <i>Clear, Mild</i> | <i>Narrow winding mountain road; Heavy traffic</i> |
| Wed 7 | | <i>8.2</i> | | | <i>8.2</i> | <i>107</i> | <i>6</i> | <i>0839</i> | <i>1520</i> | <i>VV</i> | <i>4</i> | <i>Cloudy - AM pt. cloudy - Rain - PM</i> | <i>Good effort by Rodmen, Heavy traffic; Rain last sat</i> |
| Thu 8 | <i>1.95</i> | <i>2.9</i> | | | <i>6.8</i> | <i>82</i> | <i>5</i> | <i>0845</i> | <i>1615</i> | | <i>4</i> | <i>Clear, Warm</i> | <i>Extremely Heavy traffic, Line tie ups; Move on line</i> |
| Fri 9 | | <i>6.4</i> | | | <i>6.4</i> | <i>91</i> | <i>7</i> | <i>0840</i> | <i>1528</i> | | <i>4</i> | <i>Clear, Warm</i> | <i>Extremely Heavy traffic, Hlane Hwy; Heat waves</i> |
| Sat 10 | | | | | | | | | | | | | |
| Total | <i>1.95</i> | <i>25.9</i> | | | <i>29.8</i> | <i>405</i> | <i>27</i> | | | | <i>16</i> | <i>km/Staff-Days = 1.86</i> | |

Figure 3-14.—Leveling unit weekly report.

| NOAA FORM 76-104 (3-82) | | | | | | | | | | U.S. DEPARTMENT OF COMMERCE NATIONAL OCEANIC AND ATMOSPHERIC ADMINISTRATION | | | | |
|---|---------------|--------------|------------|------------|-------------|---------|-------------------------------|------------|-------------|--|-------------------------|-----------|---------------------------------------|--|
| MONTHLY REPORT - LEVELING UNIT | | | | | | | | | | | | | | |
| OBSERVER C. SMITH | | | | | | | RECORDER M. CYR, M. DRENTH | | | | MONTH/YEAR JULY 1982 | | | |
| RODMEN, PACER J. SPARKS, M. CYR, M. DRENTH | | | | | | | PARTY G-36 | | | | | | | |
| LOCATION(S) CLE ELUM, WA.; WENATCHEE, WA. | | | | | | | PROJECT 83624100 | | | | | | | |
| LINE(S) 279 | | | | | | | SURVEY ORDER FIRST | | | | CLASS II | | | |
| DAY | DISTANCE (km) | | | | | NUMBER | | TIME | | COLL AND COMP CKS | STAFF DAY | DOWN TIME | WEATHER CONDITIONS | REMARKS |
| | DBL RUN PROG | SGL RUN PROG | 1ST RE-RUN | ADL RE-RUN | TOT ALL RUN | SET UPS | SEC-TION | 1ST SET UP | LAST SET UP | | | | | |
| 1 | | 4.6 | | | 4.6 | 146 | 7 | 0950 | 1610 | | 4 | | CLOUDY, CALM | STEEP GRADE, WINDING MOUNTAIN PASS RD. |
| 2 | | 4.4 | | | 4.4 | 86 | 5 | 0914 | 1328 | | 4 | | CLEAR-AM CALM CLOUDY-PM CALM | STEEP GRADE, EXTREMELY HEAVY HOLIDAY TRAFFIC |
| 3 | | | | | | | | | | | | | | WEEK - END |
| 4 | | | | | | | | | | | | | | WEEK - END |
| 5 | | | | | | | | | | | 4 | 8 | | HOLIDAY 4th OF JULY HOLIDAY |
| 6 | | 8.4 | | | 8.4 | 125 | 9 | 0821 | 1620 | | 4 | | CLEAR, MILD | NARROW WINDING MOUNTAIN ROAD, HEAVY TRAFFIC |
| 7 | | 8.2 | | | 8.2 | 107 | 6 | 0839 | 1520 | ✓ | 4 | 1 | CLOUDY, AM PT. CLOUDY-PM RAIN | GOOD EFFORT BY RODMEN; HEAVY TRAFFIC - RAIN, LAST SECTIONS |
| 8 | 1.95 | 2.9 | | | 6.8 | 82 | 5 | 0845 | 1615 | | 4 | 1 | CLEAR, WARM | EXTREMELY HEAVY TRAFFIC LIVE TIE SPUR; MOVE ON LINE* |
| 9 | | 6.4 | | | 6.4 | 91 | 7 | 0840 | 1528 | | 4 | | CLEAR, WARM | EXTREMELY HEAVY TRAFFIC 4 LANE HWY.; HEAT WAVES |
| 10 | | | | | | | | | | | | | | WEEK - END |
| 11 | | | | | | | | | | | | | | WEEK - END |
| 12 | | | | | | | | | | | 4 | 8 | CLEAR, WARM | SWITCH EQUIPMENT TO NEW TRUCK-AM; MOVE FROM * |
| 13 | | 7.1 | | | 7.1 | 74 | 5 | 0828 | 1409 | ✓ | 4 | 2 | CLOUDY, WARM, RAIN | HEAVY TRAFFIC, 4 LANE HWY. DOWN TIME DUE TO RAIN |
| 14 | | 6.6 | | | 6.6 | 82 | 5 | 0807 | 1543 | | 4 | 2 | CLOUDY-RAIN-AM PT. CLOUDY, MILD-PM | DOWN TIME TO RAIN; VISITED IN FIELD BY CORPS OF ENGINEERS |
| 15 | 3.25 | 2.5 | | | 9.0 | 114 | 4 | 0814 | 1627 | | 4 | | CLOUDY, MILD | EXTREMELY HEAVY TRAFFIC; DBL RUN SPUR INTO WENATCHEE, WA. |
| 16 | 4.1 | | | | 8.2 | 134 | 3 | 0815 | 1648 | | 4 | | CLEAR, WARM | DBL RUN SPUR THRU WENATCHEE; TIME SPENT TO GET BACK TO TRUCK* |
| 17 | | | | | | | | | | | | | | WEEK - END |
| 18 | | | | | | | | | | | | | | WEEK - END |
| 19 | 0.75 | 8.1 | | | 9.6 | 110 | 6 | 0752 | 1637 | ✓ | 4 | | CLEAR, WARM | 20 MIN. MOVE ON LINE; HOT ALL DAY WITH GUSTY WINDS 75°-95° |
| 20 | | 9.2 | | | 9.2 | 112 | 8 | 0822 | 1544 | | 4 | | CLEAR, WARM | HIT BM ON ROCKY REACH DAM; HOT 71°-93° F; GOOD EFFORT BY CREW |
| 21 | | 8.7 | | | 8.7 | 90 | 7 | 0809 | 1502 | | 4 | 1 | CLEAR, WARM WINDY | DOWN TIME TO STRONG GUSTY WINDS - PM; HEAVY TRAFFIC |
| 22 | | 8.9 | | | 8.9 | 103 | 7 | 0810 | 1552 | | 4 | | CLEAR, WARM | HEAVY TRAFFIC; WORKING THRU ENTIA, WA.; BAD HEAT WAVES |
| 23 | | 8.4 | | | 8.4 | 100 | 6 | 0832 | 1609 | | 4 | | CLEAR, WARM | HEAVY TRAFFIC ALL MORNING; BAD HEAT REFRACTION - PM |
| 24 | | | | | | | | | | | | | | WEEK - END |
| 25 | | | | | | | | | | | | | | WEEK - END |
| 26 | | 7.2 | | | 7.2 | 87 | 5 | 0853 | 1642 | | 4 | 2 | CLEAR, HOT | 75°-101° F; 1 HR. 45 MIN. LOST TO GOING BACK FOR TRUCK; WORK * |
| 27 | | 7.6 | | | 7.6 | 96 | 5 | 0832 | 1635 | ✓ | 4 | 1 | CLEAR, HOT | 72°-102° F; 1 HR. LOST TO MOVE ON LINE; WORK ALONG RR TRACKS |
| 28 | | 5.1 | | | 5.1 | 124 | 6 | 0840 | 1558 | | 4 | | CLEAR, HOT | 77°-102° F; WORKED ON STEEP NARROW GRADE; NO USE OF TRUCK |
| 29 | | 7.5 | | | 7.5 | 124 | 7 | 0902 | 1612 | | 4 | | CLEAR, HOT | 77°-103° F; WORKED ON STEEP GRADE; GOOD EFFORT BY CREW |
| 30 | | | | | | | | | | | 4 | 8 | | MOVE FROM WENATCHEE, WA. TO PATEROS, WA. |
| 31 | | | | | | | | | | | 4 | 34 | | WEEK - END |
| Total | 10.05 | 121.8 | | | 141.9 | 1587 | 113 | | | | 88 | | km/Staff-Days = 1.69 | * SEE REVERSE |

Figure 3-15.—Leveling unit monthly report.

justed within tolerance. Once the instrument is properly adjusted and the collimation error is known, the precision of the observations made depends in part on the consistency with which the spirit level or the compensator maintains the given line of sight. In a spirit-level instrument, this consistency is primarily determined by the degree of precision with which the bubble may be centered in the level vial. A coincidence prism or similar device enhances the precision of centering. However, since the bubble tends to "run" toward a point source of heat, the instrument must be shaded to ensure centering precision while leveling.

Compensator instruments maintain the consistency of the line of sight in various ways, some of which are described in this subchapter. In general, the automatic compensator mechanisms provide a setting precision superior to that attainable by centering a bubble. Thus, compensator instruments permit both greater productivity and improved leveling precision.

The second way in which leveling instruments are classified is according to whether or not they are equipped with micrometers. Without a micrometer, observation values may be estimated to, at best, 0.5 mm. The micrometer permits observations to be made with better precision. It permits values to be read directly to the equivalent of 0.05 mm or better.

For productive geodetic leveling, optical instruments should have the following features:

1. A telescope equipped with a large objective lens (50 to 70 mm diameter of the free aperture) to ensure brightness and good image definition.
2. A magnification power of 30 to 50 diameters.
3. A reticle etched between glass plates to ensure a consistent, dust-free image. It should include one vertical line, three horizontal lines (a middle line and two stadia lines) and, for use with scales with line graduations, a wedge. (See sec. 3.3.5, "Making an observation.")
4. Resistance to the effects of temperature change and vibration.
5. Units of the micrometer compatible with the graduations on the leveling rods. (See sec. 3.3.4, "Optical micrometer.")

Only instruments that are equipped with micrometers and that meet the appropriate standard of setting precision with respect to collimation error (table 3-1) can provide results considered to be of first-order accuracy. Although instruments with micrometers are preferred, instruments without micrometers can be used in combination with the three-wire leveling procedure to provide results considered to be of second-order accuracy.

Several different kinds of leveling instruments have been satisfactorily used for geodetic leveling in the United States. The Fischer level (fig. 3-16), designed by the Coast and Geodetic Survey, was the sole instrument used by that organization from 1900 to the early 1960's. Since then, commercial instruments that have been

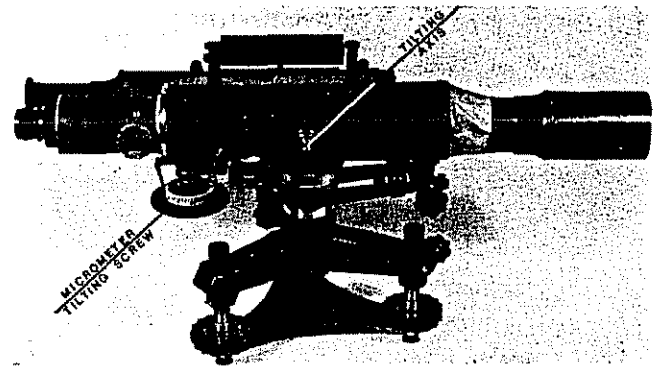

Figure 3-16.—Fischer level.

extensively used by the National Geodetic Survey include: Breithaupt NABON, Jenoptik Ni004, Zeiss Ni2, Zeiss Ni1, MOM NiA31, and Jenoptik NI 002 (figs. 3-17 through 3-21). Some features of these instruments are given in table 3-2.

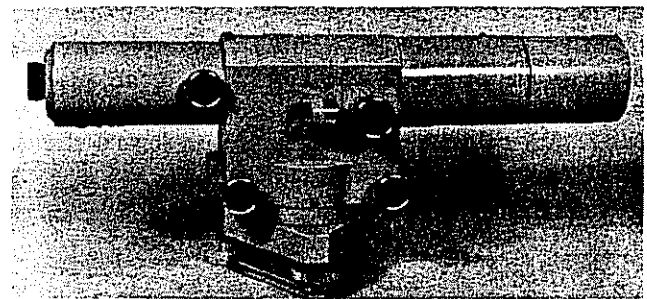

Figure 3-17.—Jenoptik Ni004.

3.3.2 Telescopic System

In a simple telescope, such as that used in older spirit-level instruments, the straight line between the optical center of the objective lens and the center of the reticle is called the line of collimation. A ray of light, passing through the optical center of a simple lens, continues to travel in its original direction as it proceeds beyond the lens. Thus, when the telescope is horizontal, the image of the center of the reticle, projected along the line of collimation to the center of the objective, defines a horizontal line of sight.

The ocular, or eyepiece, is a magnifying lens which permits the observer's eye to focus on the reticle lines and to see simultaneously on the reticle a magnified image of the scale of the leveling rod. The ocular and the observer's eye function jointly as a single lens. The ocular must be set at a fixed distance from the reticle, to enable the observer to see, without eyestrain or parallax, a sharper view of the reticle lines and the scale image. This setting must be adjusted to the eye of the individual observer. (See sec. 3.3.5, "Parallax adjustments.")

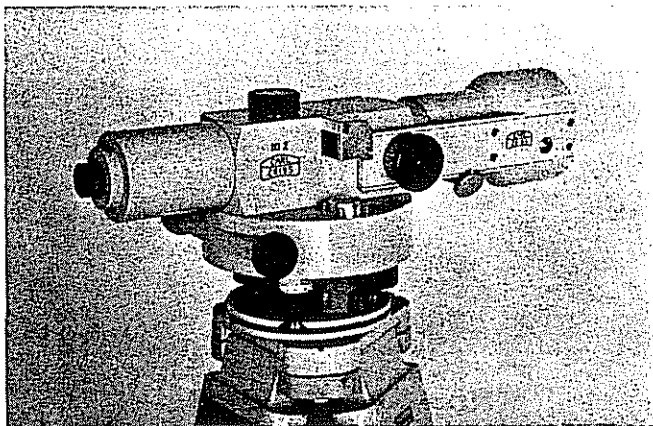

Figure 3-18.—Zeiss Ni2, with micrometer attachment.

To focus an instrument, the distance from the objective to the reticle, D_p , in figure 3-22, must be adjusted relative to the sighting distance from the objective to the rod scale, D_o . In older, external-focusing telescopes, the reticle and ocular are moved together in a combined mounting; the ocular is adjusted separately to focus distinctly on the reticle lines. In more recent versions, the reticle is in a fixed mount and only the objective lens is moved, usually by means of an external sleeve, to set the image distance as required.

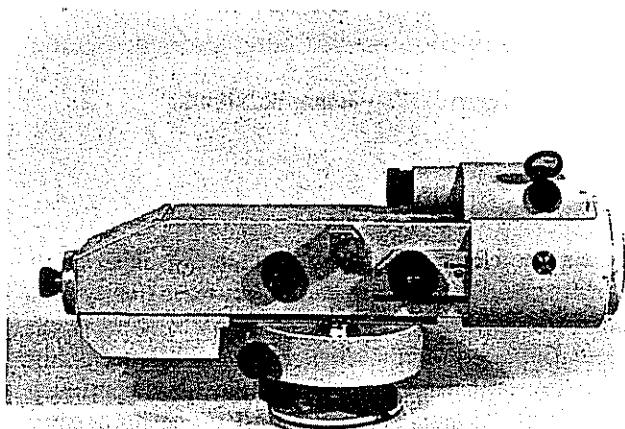

Figure 3-19.—Zeiss Ni1.

In internal-focusing telescopes, both the objective and the reticle are mounted in fixed positions (fig. 3-23). This system requires the introduction of a third, focusing lens between the objective and the reticle. The spacing between the objective and the focusing lens determines the focal length of the system. Focusing is accomplished by moving the focusing lens back and forth until the focal length is that required to make a sharp image at the reticle for the particular sighting distance. An inverted image of the rod scale is formed.

The internal-focusing system is much less likely to admit dust and moisture and is widely used in leveling instruments of high precision. In some instruments, the inverted image is made erect by a complex ocular system.

The presence of a focusing lens in the telescope requires a more general definition for the line of collimation. Because of imperfections in manufacturing, the center of the focusing lens cannot be set exactly on the line between the center of the reticle and the center of the objective. Neither can the sliding motion of the focusing lens be adjusted to coincide exactly with the line of collimation. Thus, the line of collimation deflects slightly as it passes through the focusing lens. The line of collimation can be redefined as the path followed by a ray passing through the center of the objective and deflected by intervening optical elements, finally intersecting the center of the reticle.

The line of sight provided by the instrument is the forward extension of the line of collimation, through the center of the objective to the sighted object. In the case of a deflected line of collimation, the line of sight is the extension of the segment immediately behind the objective.

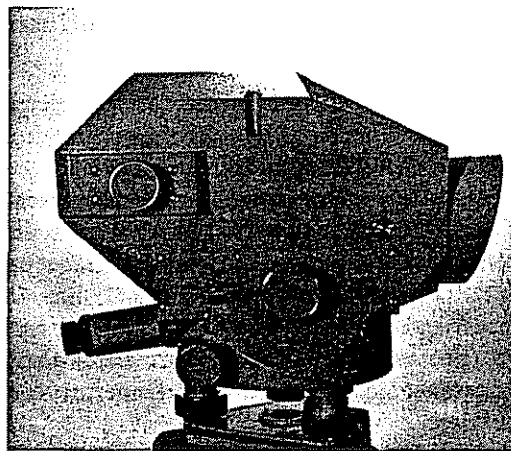

Figure 3-20.—MOM NiA31.

3.3.3 Compensator System

The presence of a compensator in an instrument eliminates the time-consuming operation of carefully centering the bubble in a level vial immediately before each observation. Instead, the instrument need only be roughly leveled with the tribrach screws, referring to a circular level rigidly attached to the instrument body.

Compensators can be grouped in two general classes: nonreversible and reversible. This manual explains two examples of nonreversible compensators: the Ni2 and Ni1 instruments. The NI 002 instrument is also described to provide an example of a reversible compensator.

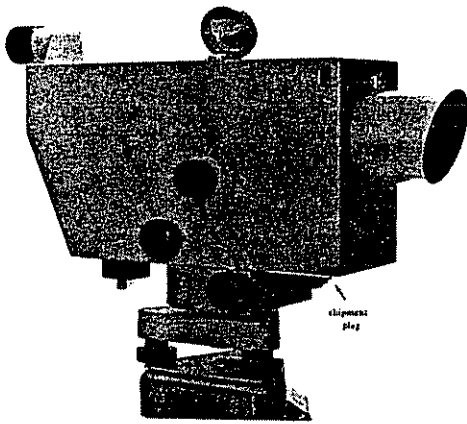

Figure 3-21.—Jenoptik NI 002.

General description. The compensator consists of one or more reflecting elements, usually prisms, set in the line of collimation of the telescope. One of the reflectors is suspended within the instrument by fine flexible links (usually Invar bands). The orientation of this movable element is changed within the telescope system by the action of gravity, whenever the alignment of the instrument body is changed with respect to the local gravity vector. The lengths and geometrical arrangement of the suspension links, the position of the center of gravity of the suspension links, and the position of the center of gravity of the movable element are carefully designed to tilt the reflecting surface. The tilt assures that the path followed by a ray of light, entering at the center of the objective, is deflected to intersect the center of the reticle.

Since the housing of the instrument is made only approximately at each horizontal setup (within a range depending on the sensitivity of the circular level), the movable element within the compensator must assume an attitude such that the segment of the line of collimation immediately behind the objective is consistently

horizontal. The angle by which it deviates from the horizontal is the collimation error. The consistency with which the movable element repeats a given collimation error when the instrument is releveled, without otherwise being disturbed (e.g., in a laboratory), is termed the setting precision. It can be limited to less than $\pm 0''.25$ in a precise instrument. It compares with the centering error of about $\pm 0''.5$ for the tubular level of a precise spirit-level instrument.

Zeiss Ni2. The first commercial compensator instrument was the model Ni2, produced in 1950 by Carl Zeiss in the Federal Republic of Germany. It has a relatively simple compensator system which contains three elements. Two are prisms rigidly attached to the telescope body. The third is an inverted pendulum, suspended by two pairs of fine Invar tapes on which the element can swing into a stable position with respect to the gravity vector. A reflecting prism is attached at the lowest part of the element. The telescope system, into which the compensator is inserted, is of the internal-focusing type. A micrometer attachment is available for the Ni2.

The basic configuration of the compensator system, with the telescope axis horizontal, is shown in figure 3-24. The fixed reflector prism and the movable prism serve, in effect, as plane mirrors. By simple reflection, the prisms cause large deflections in the line of collimation along its path from the objective to the reticle. Because of the "floating" action of the movable prism, the deflection varies in magnitude as the vertical axis of the instrument changes slightly from setup to setup. The fixed roof prism picks up the reflected line of collimation from the movable prism and redirects it to the reticle, where the image of the rod scale is formed. The roof prism not only deflects the line of collimation, but, by double lateral reflection, also reverses the image of the rod, left to right and vice versa.

The focusing system in front of the compensator generates an inverted image of the rod scale, but the prism

Table 3-2.—Features of some geodetic leveling instruments

| Instrument | Micrometer | Image | Stadia factor | Stadia constant | Setting precision |
|---------------------------------|------------|----------|---------------|-----------------|-------------------|
| Compensator instruments | | | | | |
| Jenoptik NI 002 (reversible) | Integral | Erect | 100 | +0.4 m | $\pm 0''.05$ |
| MOM NiA31 | Integral | Erect | 100 | +0.37 m | $\pm 0''.1$ |
| Zeiss Ni1 | Integral | Erect | 100 | 0.0 | $\pm 0''.1$ |
| Zeiss Ni2 | Optional | Erect | 100/333 | 0.0 | $\pm 0''.2$ |
| Wild NA2 | Optional | Erect | 100/333 | 0.0 | $\pm 0''.3$ |
| Spirit-level instruments | | | | | |
| Wild N3 | Integral | Inverted | 100/333 | -0.2 m | $\pm 0''.2$ |
| Jenoptik Ni004 | Integral | Inverted | 100 | 0.0 | $\pm 0''.23$ |
| Breithaupt NABON | Optional | Inverted | 100 | 0.0 | $\pm 0''.2$ |
| USC&GS Fischer | None | Inverted | 300/333 | +0.6 m | $\pm 0''.5$ |

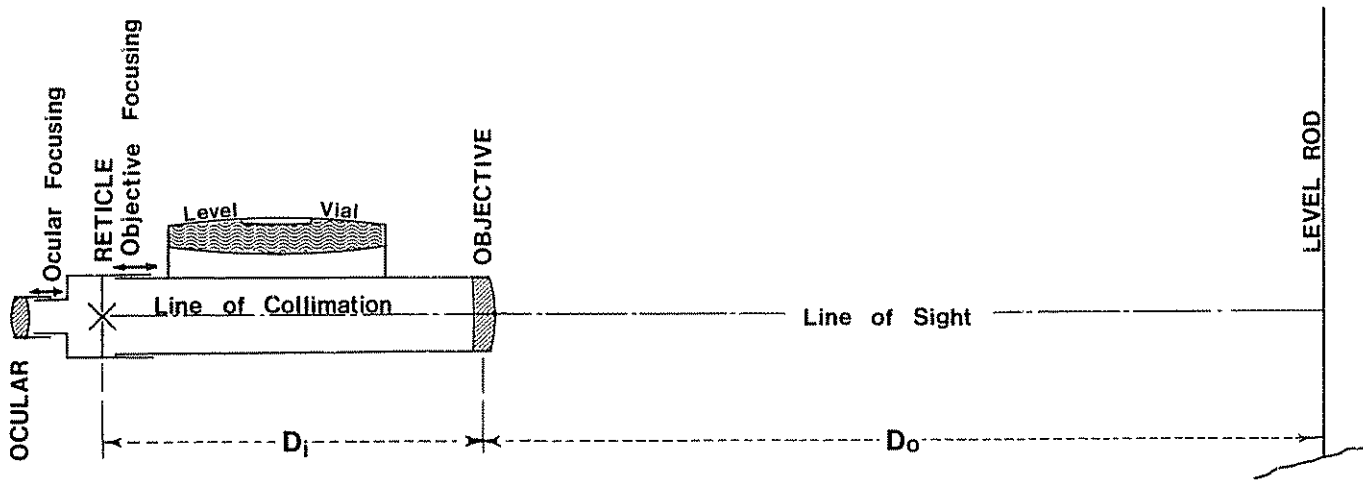

$$\frac{1}{D_i} + \frac{1}{D_o} = \frac{1}{f}$$

Figure 3-22.—External-focusing telescope.

system erects the image from top to bottom and reverses it left to right. Thus, the observer sees an erect, direct image.

With the telescope axis horizontal, the line of collimation is horizontal before reflection by the fixed reflector prism. The line which connects pivot points *A* and *B* in the body of the instrument and the line which connects pivot points *C* and *D* by which the compensator is suspended are also horizontal. Points *C* and *D* are placed symmetrically with respect to *A* and *B*, by virtue of their suspension on either side of the movable prism. This requires four suspension ribbons in all, of nearly equal length. The line of collimation is deflected 45° by reflection from the first fixed prism, by 90° in the opposite direction from the horizontal surface of

the movable prism, and again by 45° to coincide with the telescope axis. Thus, the image directed by the objective along the line of collimation is viewed at the ocular as if no deflection had occurred.

When the instrument is roughly leveled (fig. 3-25), the telescope axis is tilted within 4' from a horizontal position and the line of the pivots, *AB*, is tilted by the same amount, α . Because of the flexible suspension ribbons, the supports *C* and *D* shift to a new position. The lengths, *AC*, *BD*, and *CD*, remain unchanged and the suspension ribbons bend slightly at *A*, *B*, *C*, and *D*, as if the supports were frictionless pivots. (Actually, the ribbons assume complex curved alignments, but if the axis is tilted only slightly, this causes no significant error.)

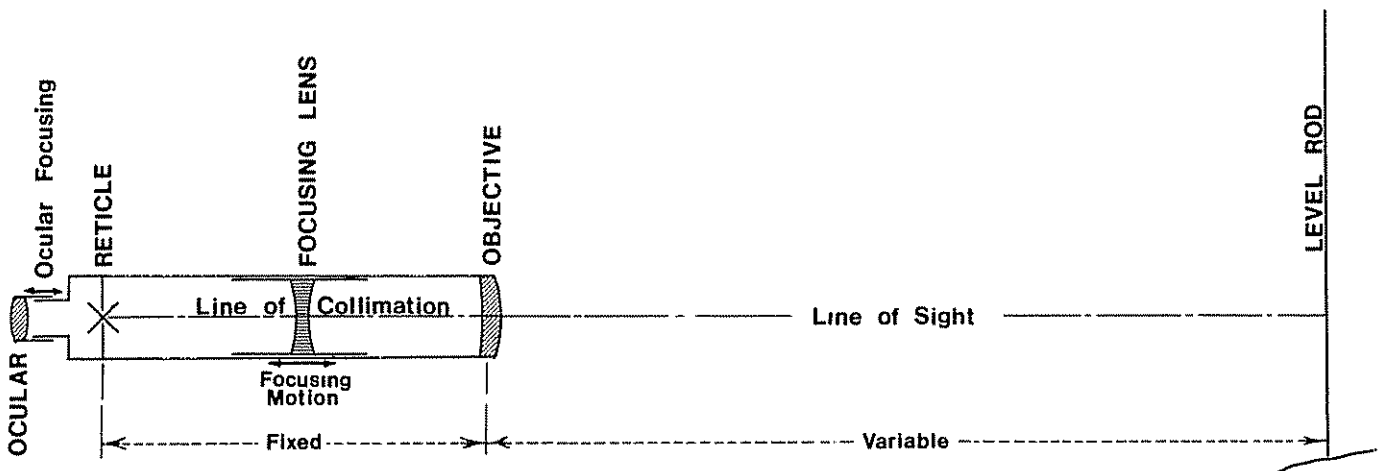

Figure 3-23.—Internal-focusing telescope.

ZEISS Ni2 COMPENSATOR Horizontal Position

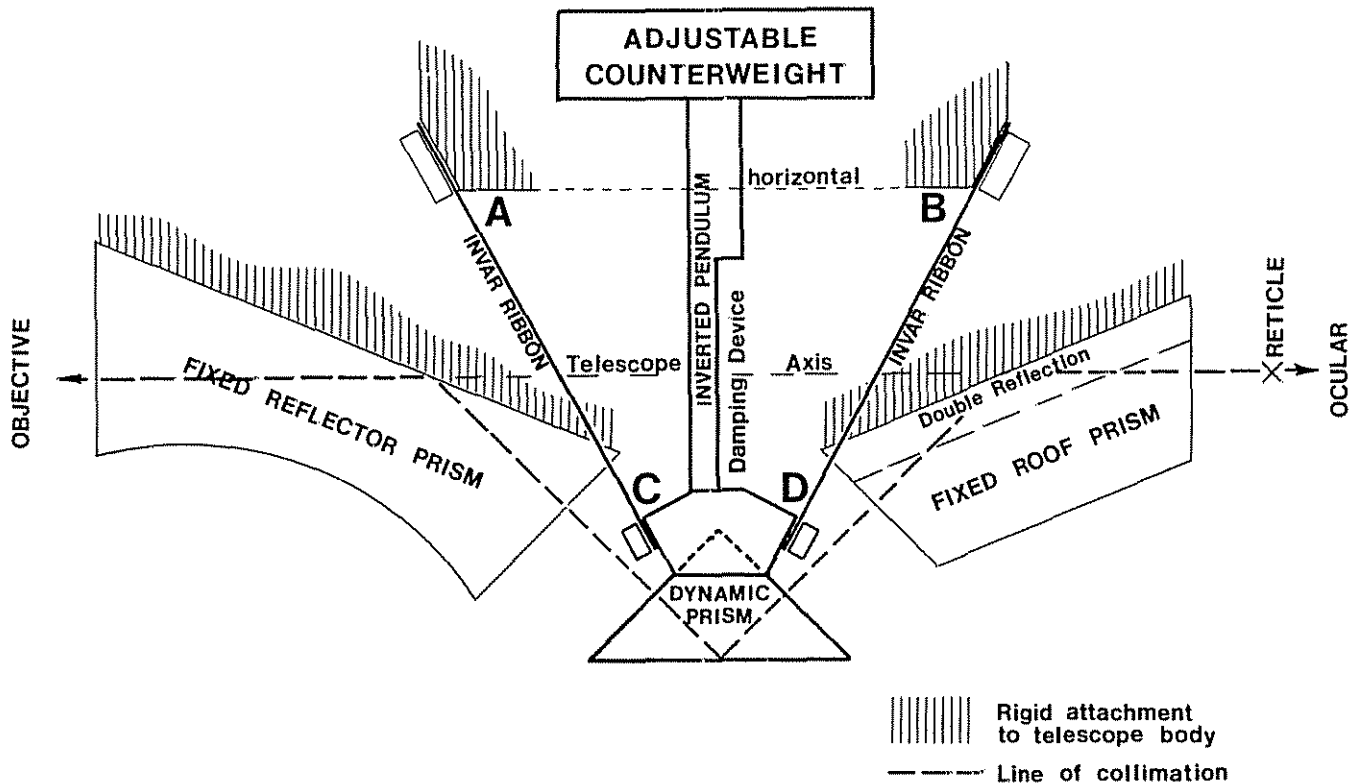

Figure 3-24.—Ni2 compensator system, telescope axis horizontal.

Because of the shift of the support, CD , the lower reflecting surface of the movable prism is tilted in the same direction as the line of pivots, AB , but through a larger angle, β , by the relationship:

$$\beta = n \times \alpha.$$

The factor, n , is a function of the dimensions of AB and CD , the perpendicular distance from AB to CD when AB is untilted, and the height of the center of gravity of the suspended system above the axis CD . The magnitude of the factor in a particular instrument depends on the location of the compensator in the telescope.

In essence, the compensator must deflect a ray of light, entering a telescope whose axis is tilted by a small angle from horizontal, through the angle necessary to redirect the ray to the center of the reticle, as shown schematically in figure 3-26. In the Ni2 compensator the ray is deflected three times, but the net effect is that of a single deflection of the correct magnitude.

The position assumed by the movable element for any tilt within its functioning range depends on the dimensions of the suspension system and the position of the center of gravity. Figure 3-27 shows the condition that must be met for stability of the movable element during a setup. A , B , C , and D are the pivot points shown with the same notation as in figure 3-24. G is the center of gravity at a height, h , above the line of pivots, CD . Stability (no oscillation) occurs automatically when

the gravity vector, acting downward from G , passes through the point of intersection, I , of the extensions of the suspension links AC and BD .

When the axis is tilted at a small angle, motion occurs at all four pivots. Since they are essentially the equivalent of frictionless pins, the system swings past the stable position, swings back, and then continues to oscillate about the stable position until the motion is damped. To damp it quickly, a loose-fitting, air piston-and-cylinder damper is attached between the dynamic element and the instrument frame. Without mechanical contact between the piston and the cylinder, the device utilizes the resistance of the air pressure generated by the compression stroke to damp the oscillation in less than a second. Such a damper is vital to the productive use of a compensator instrument.

When stability is attained, the line of collimation is horizontal. Any small residual tilt resulting from imperfections in the instrument is adjusted by rotating a wedge-shaped optical element at the front of the objective. (See sec. 4.3.1, "Rotary-wedge attachment.")

This discussion of the basic configuration of the compensator system has been developed around the Ni2 instrument because the details of application are relatively straightforward. Application to other compensator instruments would follow the same general theory, but might vary considerably in detail.

Zeiss Nil. The Nil instrument, like the Ni2, is produced by Carl Zeiss in the Federal Republic of Ger-

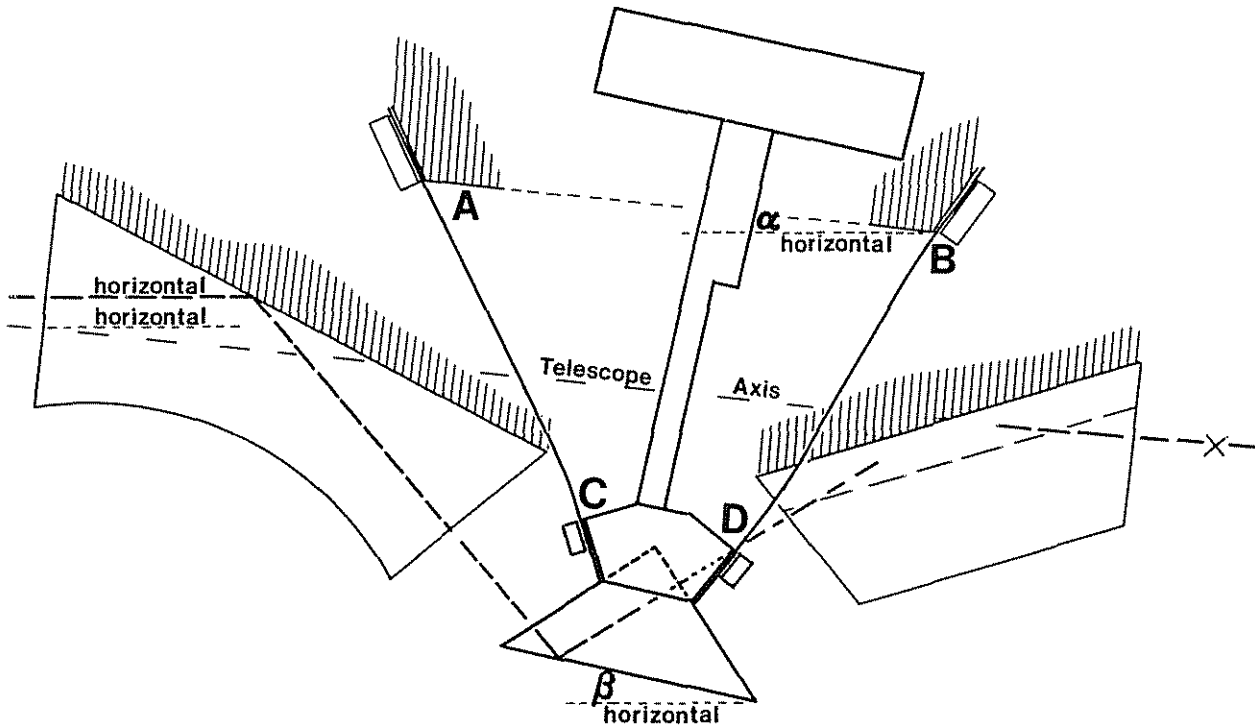

Figure 3-25.—Ni2 compensator system, telescope axis tilted.

many. Designed some years after the Ni2, it is larger, more precise, and intended specifically to produce leveling results of better accuracy. It is equipped with a high-powered telescope and a built-in, plane-parallel plate micrometer. The compensator (fig. 3-28) of the Ni1 is generally similar to that of the Ni2. The movable element is an inverted pendulum suspended on four Invar ribbons. The line of collimation is deflected three times by reflection from prisms. Figure 3-29 shows the schematic arrangement of the compensator system when the telescope axis is tilted.

The compensator varies from that of the Ni2 in the following particulars. First, the Invar suspension ribbons cross at a point above the base of the movable

element. This "X-suspension" responds to tilting and to the gravity vector in a manner similar to that of the Ni2 (a "V-suspension"). However, the axis of the movable element tilts in the direction opposite to the tilt of the telescope axis.

Second, the three deflections of the line of collimation are accomplished by only two prisms. The roof prism reflects once; the movable prism reflects twice, internally.

Third, the movable element is not symmetrical about the support system. The roof prism is mounted fairly high above the base pivots and to the rear of the support system, near the ocular. The resulting eccentricity is balanced by the placement of a large damping system at a position on the objective side of the sup-

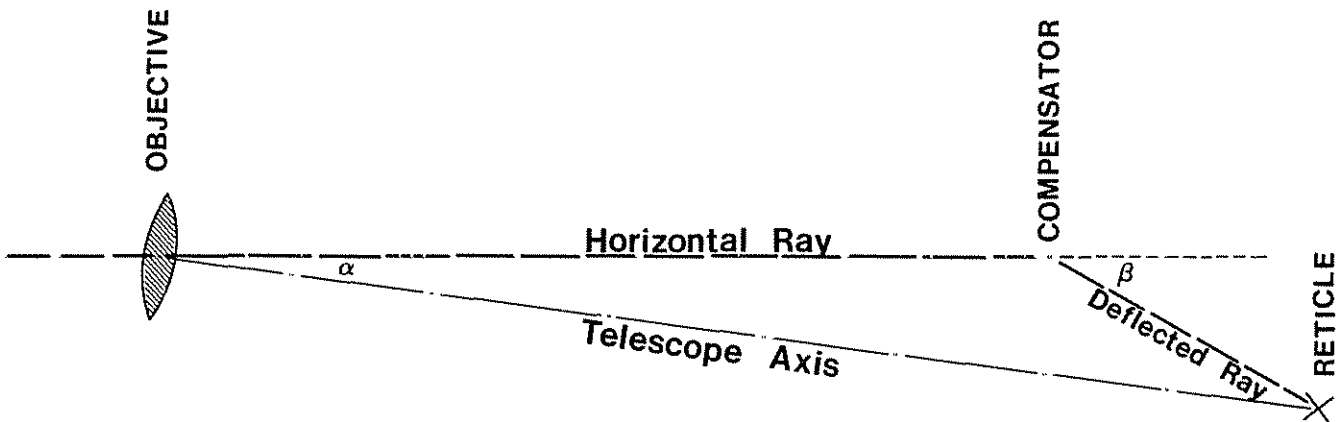

Figure 3-26.—Deflection of the line of collimation by the compensator.

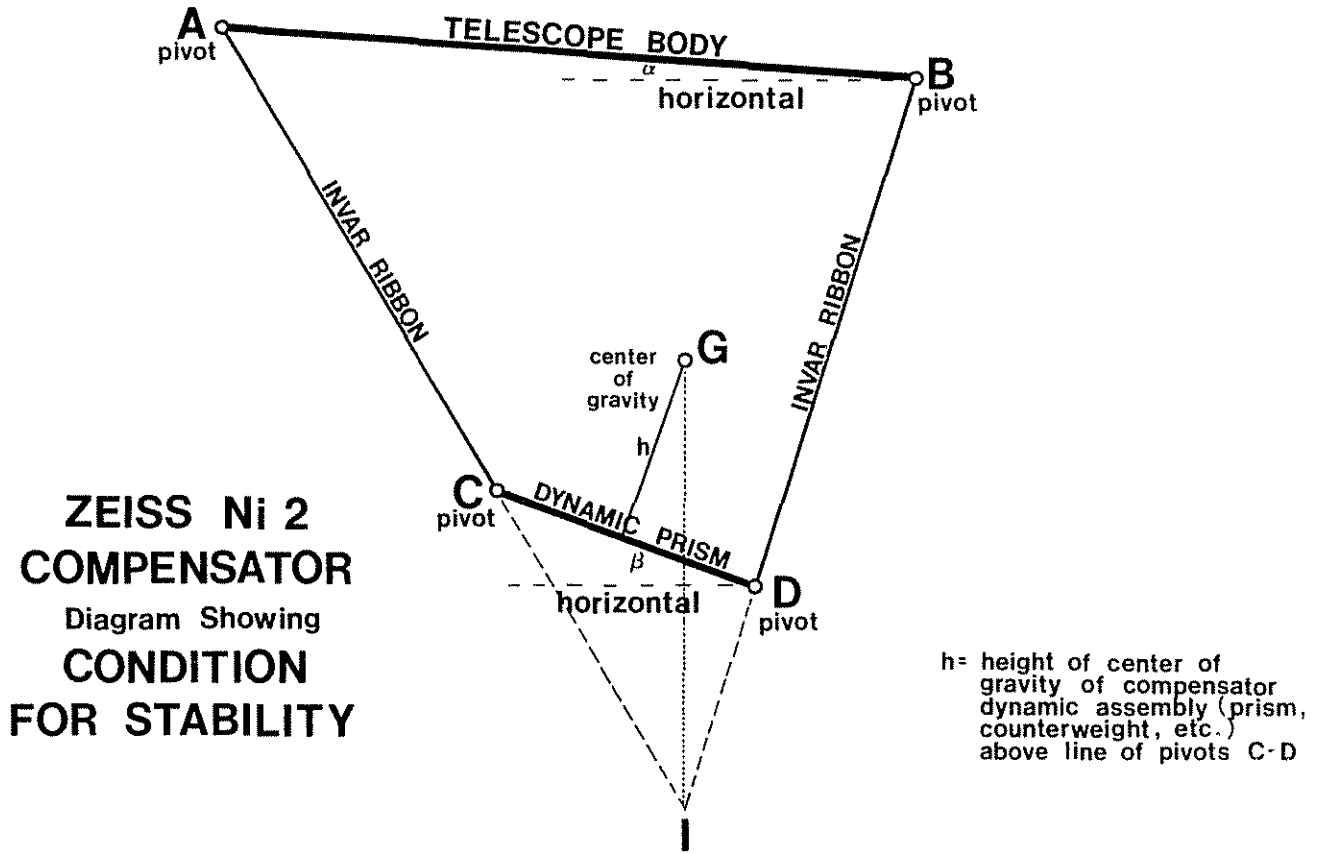

Figure 3-27.—Condition for dynamic stability of the Ni2.

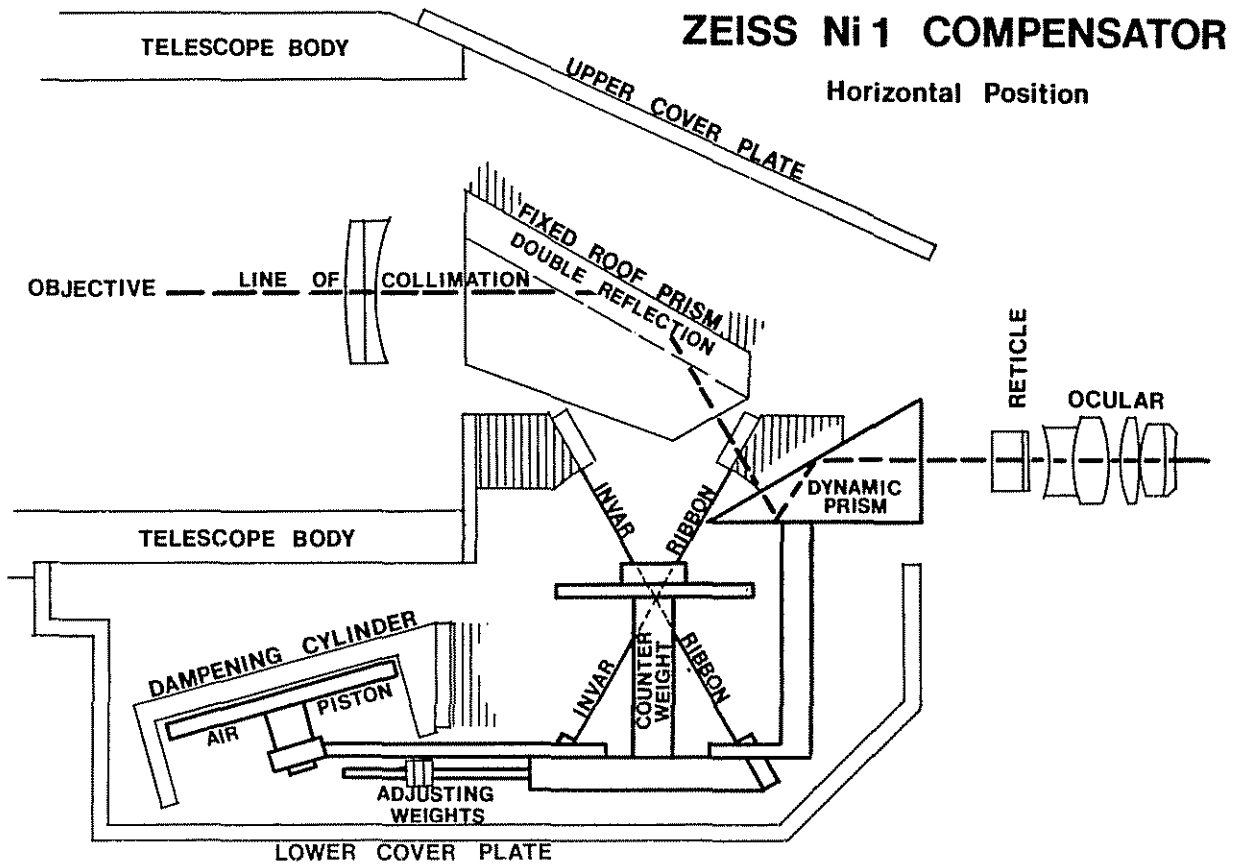

Figure 3-28.—Ni1 compensator system, telescope axis horizontal.

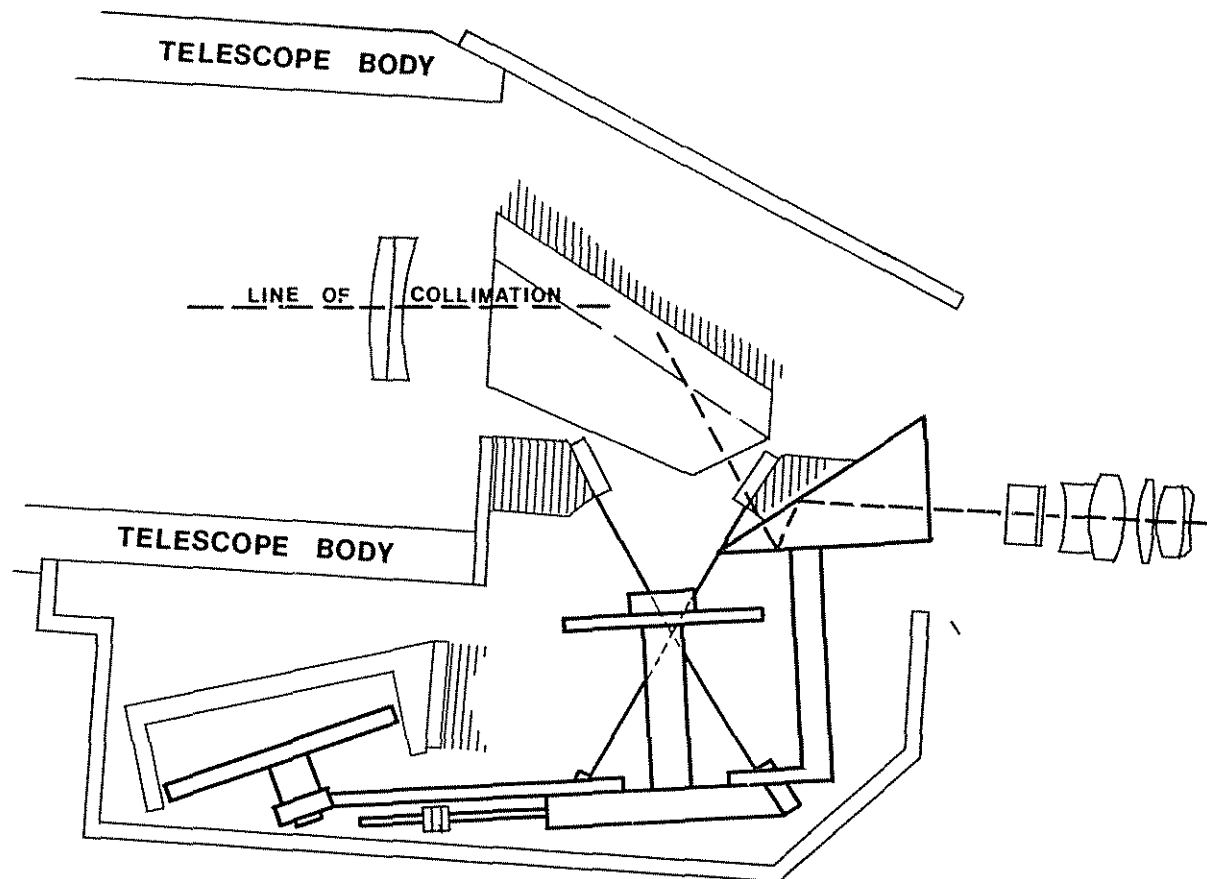

Figure 3-29.—Ni1 compensator system, telescope axis tilted.

ports. This does not affect the response of the movable element to gravity. The condition for stability still requires that the gravity vector from the center of gravity of the movable element pass through the point of intersection of the supporting ribbons, as projected on a vertical plane. A major attribute of the Ni1 is that the mass of the element is greater than that in the Ni2, which reduces its natural vibration frequency. This makes the system more stable in the presence of external vibrations.

Fourth, the Ni1 has a larger objective aperture and a higher-powered telescope than the Ni2. These features provide a sharper and more distinct view of the rod scale, a factor that improves the precision possible when intercepting the graduations.

Jenoptik NI 002. A major innovation in compensator instruments is the Jenoptik NI 002, manufactured in Jena, German Democratic Republic. Although its optical system is complex, the compensator operates on a simple principle by adapting a vertically suspended, plane mirror.

Figure 3-30 shows that the optical system defining the line of collimation has been reduced to only a few components. The objective lens, 2, transmits rays of light to the optically flat, compensator mirror, 3, which is supported in an essentially vertical position by links, 15, in an "X-suspension" array, similar to that of the Zeiss Ni1. The instrument is focused by moving the

mirror backward or forward. The reticle, 4, is engraved at the front of the objective lens. Therefore, the focusing distance is the total distance from the objective to the mirror and back to the objective.

The line of collimation, then, consists of two superimposed segments, both of which are horizontal if the compensator mirror is aligned with the direction of gravity. The important task of providing a horizontal line of sight is accomplished by the simple arrangement of directing rays from the objective to a suspended mirror, then reflecting them back to the reticle on the front surface of the objective. The only adjustment required is to distribute small counterweights so the compensator mirror hangs precisely in line with the direction of gravity.

The compensator mirror is manufactured to be a precise optical plane; both "front" and "back" surfaces are precisely flat and parallel within the fine tolerances of optical technology. The use of the double mirror as a reversible compensator is made possible by the provision of the rotary motion, h , with which, by the simple shift of a knob, the mirror and its suspension system can be rotated 180° . After rotation, the line of collimation is reflected from the reverse side of the mirror.

Since the line of collimation is tilted from horizontal by an angle, α_1 , in one position, it is tilted by a nearly equal and opposite angle, α_2 , after the mirror is rotated 180° (fig. 3-31). If the rod scale is observed twice, once

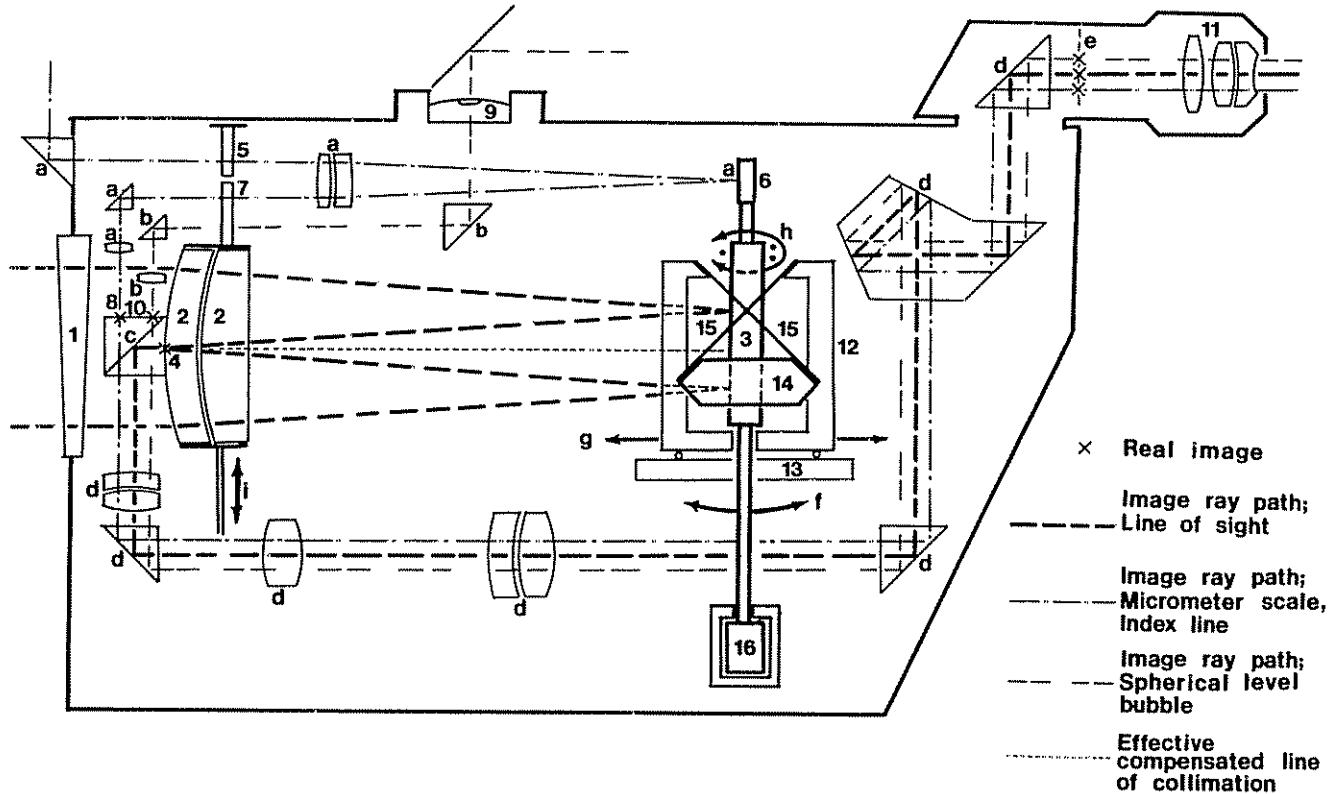

Figure 3-30.—Diagram of the NI 002.

1. Rotatable optical wedge for adjusting mean line of collimation.
 2. Telescope objective.
 3. Compensator mirror for telescope image.
 4. Reticle engraved at front surface of objective lens.
 5. Transparent plate with micrometer index line.
 6. Compensator mirror for micrometer index-line image.
 7. Transparent plate with micrometer scale, attached to objective lens assembly.
 8. Real image of combined images of micrometer index line, 5, and micrometer scale, 7, projected on face of prism *c* via optical train *a*.
 9. Circular level, for roughly leveling the instrument.
 10. Real image of bubble in circular level. projected on face of prism *c*, at 10.
 11. Ocular assembly.
 12. Compensator support.
 13. Compensator support base.
 14. Compensator suspension block, attached to mirror, 3.
 15. Flexible bands for compensator suspension block.
 16. Air piston assembly for damping oscillation of compensator.
- a* Optical train, transmitting image of micrometer scale, 7, and index line, 5; image formed on face of beam-splitting prism *c*, at 8.
 - b* Optical train, transmitting image of circular level bubble, 9; image formed on face of beam-splitting prism *c*, at 10.
 - c* Beam-splitting prism, collecting images from the objective, at 4, and from optical trains *a* and *b*, at 8 and 10, to be transmitted to image plane *e*, via optical train *d*.
 - d* Optical train, transmitting combined images from 4, 8, and 10, to image plane *e*
 - e* Image plane for optical train *d*, with images of rod and reticle lines from telescope combined with images of micrometer scale and index line (from optical train *a*) and image of circular level (from optical train *b*)
 - f* Pendulous motion of compensator system.
 - g* Sliding motion of compensator system, to focus telescope image on reticle at 4.
 - h* Reversing motion of compensator system; provides 180° rotation about vertical axis, interchanging mirror surfaces “ ” and “ : ” on 3; also reverses micrometer mirror 6
 - i* Vertical sliding motion of objective assembly, carrying micrometer scale 7, to set line of sight on integral rod graduation, thus serving as a mechanical/optical micrometer.
 - j* Location for plug to prevent vertical sliding of objective assembly during shipment

in position one () and once in position two (:), the mean of the readings is essentially free from the effect of the collimation errors. Any small residual tilt in the mean line of collimation ("quasi-absolute horizon") may be adjusted within 1"0 of horizontal by rotation of a wedge-shaped optical element (item 1 in fig. 3-30).

Note that the difference between the readings is proportional to the angular difference, $\alpha_1 - \alpha_2$, between the collimation errors. This angle is normally kept within 20"0 by adjusting the counterweights on the compensator assembly.

During a setup of micrometer leveling with an imbalance, Δs (backsight distance minus foresight distance), the angular difference causes a difference between the elevation difference observed in compensator position one, Δh_L , and that observed in compensator position two, Δh_H :

$$\Delta h_L - \Delta h_H = Q \times \Delta s.$$

This must be considered when checking observations for blunders. Since the angular difference fluctuates somewhat as the air temperature changes, its maximum magnitude should be used to compute the tolerance for the reading check. (See sec. 3.7.2, "Instructions: reading check.")

The precision of the NI 002 depends primarily on the relationship between the objective, the compensator mirror, and the reticle. The remainder of the optical system, which merely serves to transmit the scale image from the compensator to the ocular, is essentially described in the explanatory key to figure 3-30.

3.3.4 Optical Micrometer

Around 1910, Heinrich Wild made possible a significant improvement in the precision of leveling obser-

vations when he invented the plane-parallel plate micrometer. This optical device eliminates the need to estimate the intercept of the middle line of the reticle as it appears against the image of a rod scale. The micrometer permits the image of the scale to be shifted vertically until an integral graduation is precisely intercepted by the middle line. The amount of vertical shift may then be measured.

The function of the parallel-plate micrometer depends on Snell's law. A ray of light, incident on a plane air-glass surface at an angle, l , is refracted toward the perpendicular to the plane surface (fig. 3-32). After traversing a finite thickness of glass, t , and on passing through a glass-air surface parallel to the first, it is refracted through an equal and opposite angle. It thus emerges parallel to the original ray, but offset from it by a small distance, d . The distance may be computed from the index of refraction, n , for glass relative to air, as follows:

$$d = t[(n-1)/n] \tan l$$

On a leveling instrument, the plane-parallel glass plate is normally mounted at the front of the objective. The plate may be partially rotated about an axis perpendicular to the vertical axis of the instrument, by means of a knob. With the plate unrotated, the line of sight usually intercepts the rod scale at some point between two graduations, as shown in figure 3-33. Rotating the plate at an angle to the incident ray produces an apparent vertical shift of the field of view.

To measure the interval between the intercept of the line of sight and the first graduation below it, the plate is rotated until a graduation is shifted into coincidence with the middle line of the reticle (fig. 3-34). Since the interval depends on the tangent of the angle of rotation

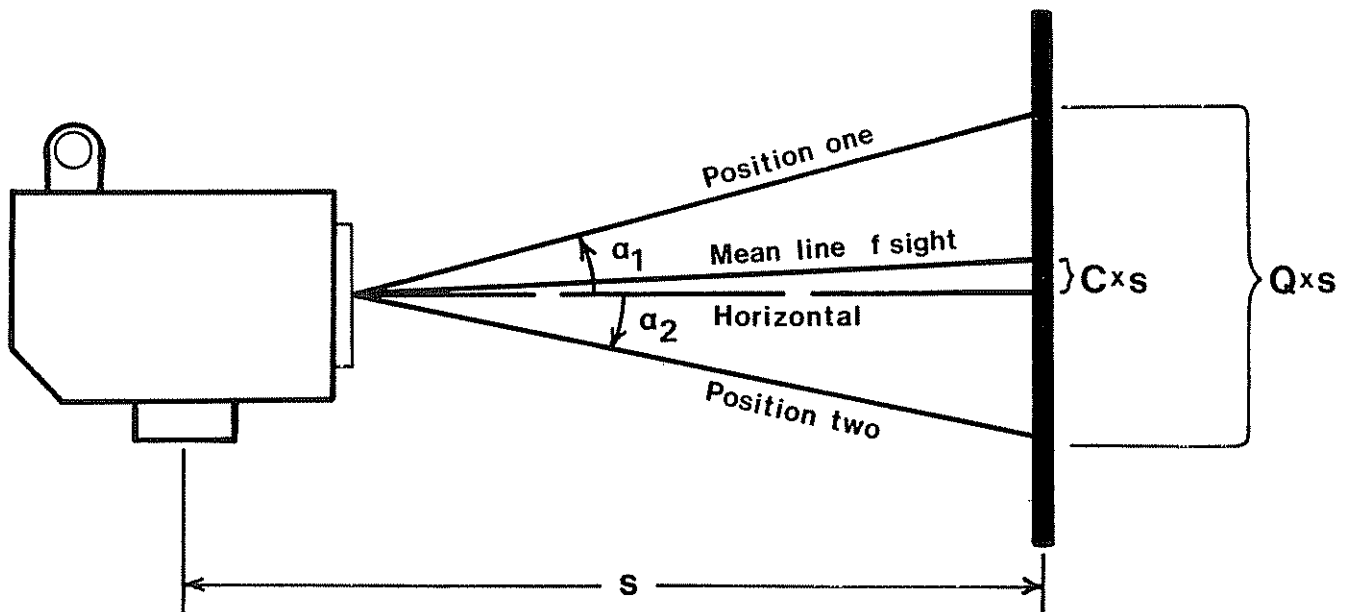

Figure 3-31.—Lines of sight provided by the NI002.

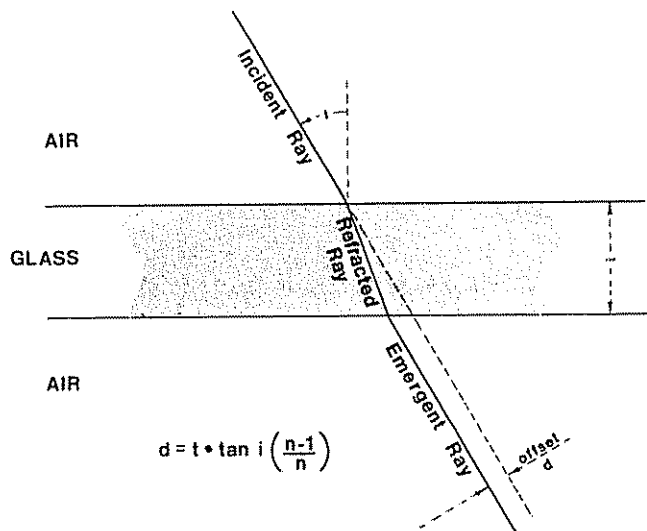

Figure 3-32.—Snell's law applied to a plane-parallel plate micrometer.

of the plate, uniform rotation of the knob generates a tangent function of the angle of rotation of the plate. A drum scale, attached to the knob, permits the values of the function to be read, in units that measure the vertical shift of the line of sight.

The rotating range of the micrometer plate is 10 micrometer units (fig. 3-35). To avoid exceeding the limits imposed by the approximations involved in the equation, the range provides equal displacement on each side of the unrotated position of the plate. Rotating the upper edge of the plate toward the eyepiece causes an apparent lowering of the field of view, or raising of the line of sight. Rotating the upper edge of the plate away from the eyepiece causes an apparent raising of the field of view, or lowering of the line of sight. For convenience, the micrometer units are usually numbered from 0, with the line of sight at its maximum upward displacement, to 10, at its maximum downward displacement. Thus, when the plate is unrotated, the reading is 5 units.

As a result of this system of numbering, a micrometer reading is positive and must be added to the value of the intercepted graduation. Since the readings are referred to its maximum upper displacement (not to the undisplaced line of sight) the readings are 5 micrometer units too large. However, since they are too large by a constant amount, the difference of elevation obtained from the difference of the foresight and the backsight is mathematically correct.

The maximum vertical range of shift of the line of sight is set equal to the interval between two adjacent graduations on the rod scale, i.e., one rod unit. Because of this, only one graduation may be intercepted for any fixed position of the instrument and the rod.

The foregoing details apply to the most commonly used micrometer system. Some instruments (e.g., the Jenoptik NI 002) achieve the same effect by shifting the objective lens itself vertically. The amount of shift is measured directly against an attached linear scale.

Optical micrometers are available for use with rods graduated in any of a variety of units. One micrometer unit is normally equivalent to one-tenth of a rod unit. Readings are made to the nearest one-hundredth of a rod unit (equivalent to 0.05 mm with half-centimeter rods), as indicated by subdivisions, or can be readily estimated. Always use a micrometer compatible with the units of the rod scale; otherwise confusion and blunders will result.

3.3.5 Use and Maintenance

During field use the leveling instrument is subject to continual physical stress, including shock, vibration, wind-blown dust and dirt, moisture, and temperature change. Even the most rugged instrument cannot withstand this assault indefinitely. The observer should take every possible precaution to protect it from these conditions.

Tripod. To ensure a stable platform for the instrument, the tripod on which it is mounted must be strong and rigid. It should be constructed of a material that is affected very little by temperature change. To provide stability in various types of soil, the feet of the tripod should have tapered metal shoes with projections that permit them to be pushed into the ground.

The legs should be of sufficient length to allow the observer to stand erect. For a given observer this means that the length necessary depends upon the location of the instrument eyepiece, which can vary considerably from instrument to instrument. The Jenoptik NI 002 (fig. 3-21) requires a shorter tripod than the MOM NiA31 (fig. 3-20) or the Zeiss Nil (fig. 3-19). For routine leveling, tripods with adjustable legs are not recommended.

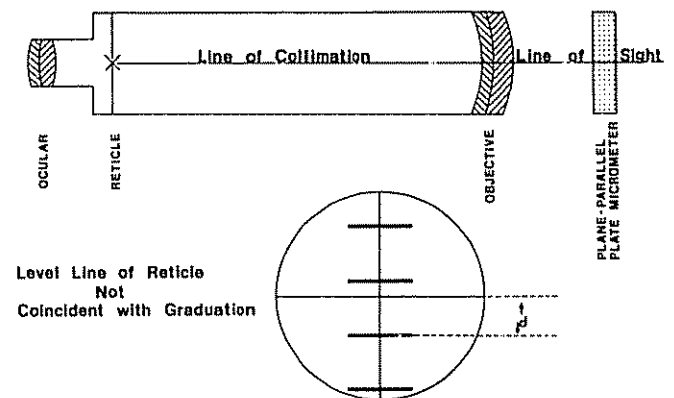

Figure 3-33.—Plane-parallel plate unrotated.

The observer should check the condition of the tripod head each day. A loose head makes it very difficult to maintain the instrument in a level position throughout the backsight and foresight of each setup. The hinge assembly should cover the legs snugly. Hinge tension is properly adjusted when each leg, raised to a horizontal

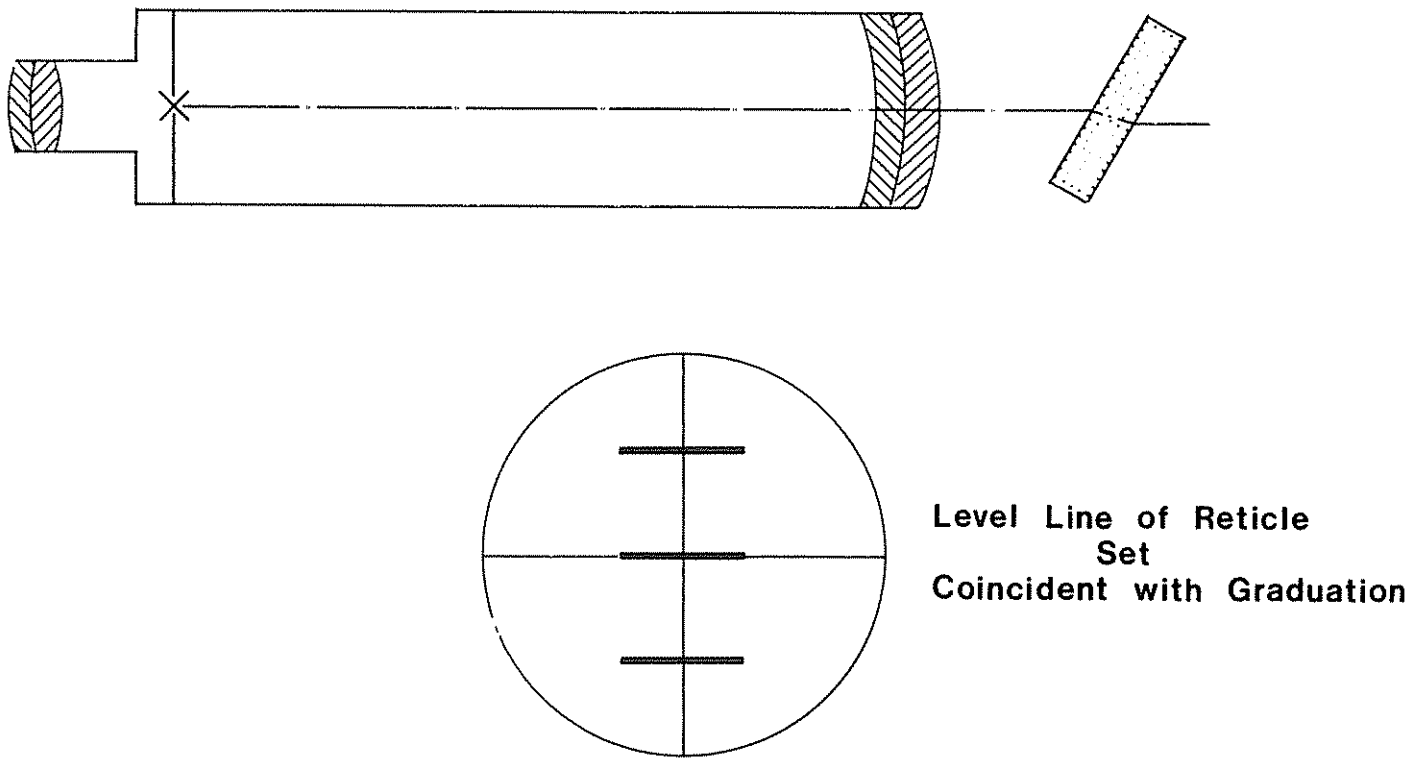

Figure 3-34.—Plane-parallel plate rotated to intercept a graduation.

position, slowly drops of its own accord.

Bolts, located between each pair of legs, should be tightened as necessary to reduce any play between the platform and the legs. Many modern tripods are constructed with plastic bushings that may crack or shatter if the bolts are overtightened, so care should be exercised when making this adjustment. The bushings may be replaced by taking the hinge assembly apart. The tripod hinge assembly should not be stressed by lifting a leg too high or by forcibly jamming the legs simultaneously into the ground. Shock from the latter activity may severely damage the leveling instrument.

The tripod should be placed firmly on the ground and each leg should be pushed in individually, to ensure a stable setup. Setups on bituminous pavement (such as asphalt) must be avoided, since significant tripod settlement may occur. The same precaution applies to frozen ground, where, if possible, the frozen layer should be broken through or shoveled away before setting up the tripod.

Set the tripod to afford as high a line of sight as possible. When leveling along a road shoulder that slopes down away from the road, if the instrument is used at the side (as is the NI 002), point one tripod leg away from the road and stand between the other two legs.

Tribrach. The tribrach, which supports the instrument, is another factor in maintaining instrument stability. The tribrach should be mounted on the tripod head so

the foot screws are aligned with the tripod legs. Then, the bell-shaped bolt below the tripod head is screwed up through the two plates forming the bottom of the tribrach. It should be just tight enough to prevent the tribrach from shifting when transporting the instrument-tripod assembly. If overtightened, the plate may eventually loosen enough to wobble. When this occurs, tighten the screws that hold the upper plate against the footscrew pedestals. These screws should never be so tight that the downward pressure causes wear on the pedestals.

On many leveling instruments the tribrach is an integral part of the instrument, not removable in the field. Some instruments (e.g., the NI 002) may be detached from the tribrach by loosening a setscrew on the tribrach. The function of this screw should not be confused with that of the tangent screws immediately above it. Check periodically to ensure that the setscrew is tight.

Foot screws. Each of the three foot screws used for leveling the instrument should be adjusted to the tension that the observer finds is practical. First, turn each foot screw until the small hole on the inside is aligned with a similar hole on the outside. Then, insert an adjusting pin and turn the entire screw assembly to loosen or tighten the tension (the direction depends on the particular instrument). One-quarter to one-half turn in either direction is usually sufficient. The tension should not be so great that it is difficult to feel when a stop has been reached. Do not force the foot screws past their upper or lower stops because this damages the threads.

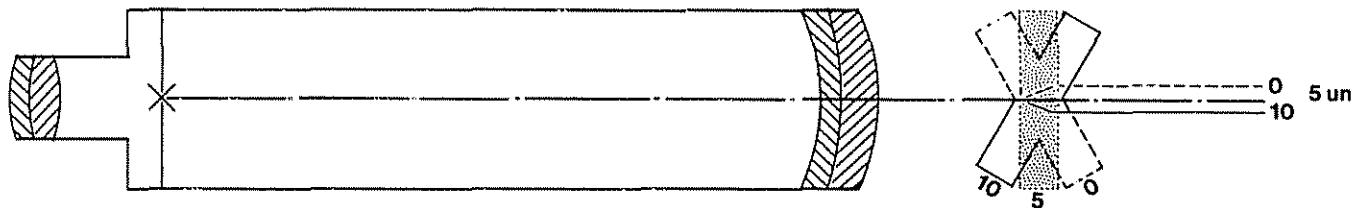

Figure 3-35.—Plane-parallel plate micrometer scale.

Carrying the instrument. After the instrument is mounted on the tripod, carry the entire assembly vertically, resting it against a shoulder and supporting it by gripping the tripod rungs with one or both hands (fig. 3-36). The tripod should not be balanced across the shoulder, since this puts the instrument in a more vulnerable position and subjects it to greater stress from shock or vibration. Use your body to cushion shocks to the instrument. When it is carried on the side step of a truck, rest the tripod feet not on the metal step, but on the toe of a boot or a thick elastic cushion (such as a section of tire) mounted expressly for this purpose.

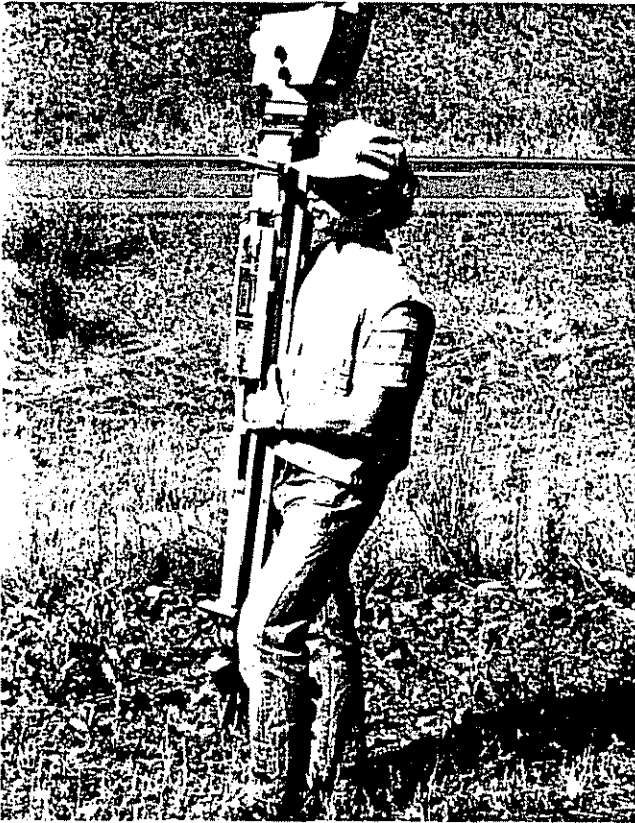

Figure 3-36.—Carrying the instrument-tripod assembly.

Leveling the instrument. At every setup the instrument must be roughly leveled. (See sec. 3.3.3, "Compensator system.") A circular level (known also as a spot or bull's eye) is attached to the body of the instrument for this purpose. The bubble in the level is centered to ensure that the compensator (or the bubble in the tubular level of a spirit-level instrument) is freely suspended.

To rough-level the instrument, first, turn it so the circular level and one foot screw form a line perpendicular to the line formed by the other two foot screws (fig. 3-37). Turn the two foot screws simultaneously, either toward or away from each other, to effect side-to-side movement of the bubble. Then, turn the first foot screw to move the bubble forward and backward, until it is centered.

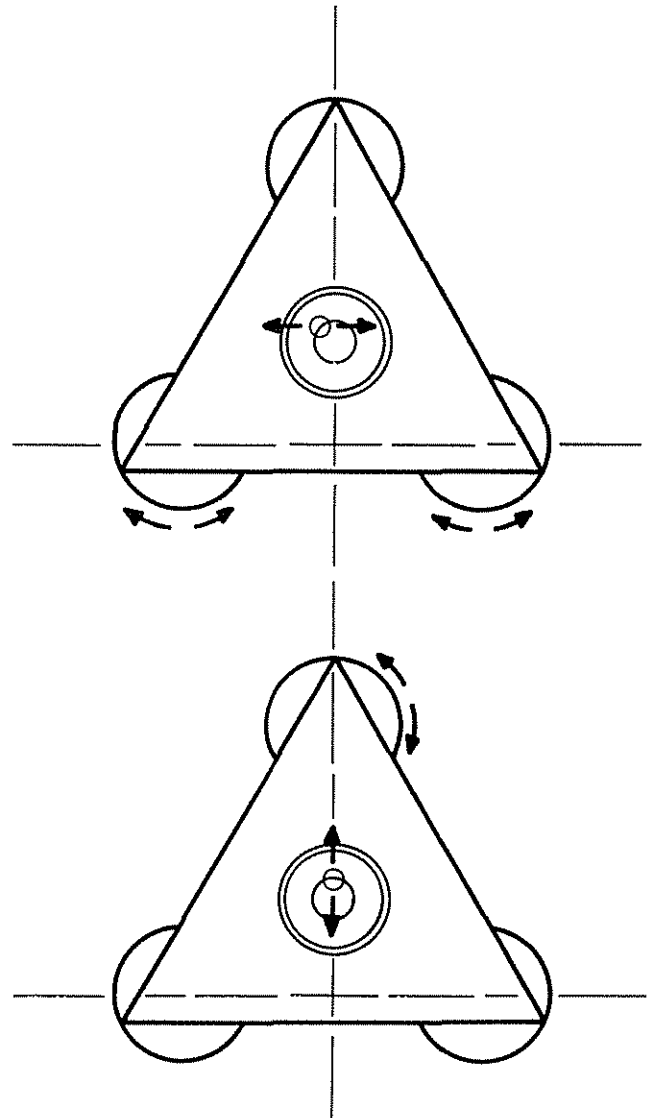

Figure 3-37.—Centering the bubble in a circular level.

Many instruments are equipped with mirrors or other optical mechanisms for observing the circular level. These mechanisms may invert or rotate the bubble image.

For example, the bubble on the NI 002 may be observed either in a mirror or through the eyepiece. In the mirror image, side-to-side movement is the same as, and forward-backward movement is opposite to, what the observer would expect when looking directly down on the bubble. The relationship of the eyepiece image to the direct view of the bubble is more complex, depending on the orientation of the eyepiece. If the eyepiece is turned to the side of the instrument, side-to-side movement appears forward-backward, and vice versa. With practice, the observer can learn to level the instrument efficiently while observing the bubble through the eyepiece.

Circular-level adjustment. At the start of work each day, and after any severe shock to the instrument, the observer should check that the circular level is properly adjusted. A circle is inscribed on the vial glass to provide a reference for assessing the bubble's movement. When the instrument is sufficiently level, the bubble should remain precisely centered as the instrument is slowly turned through a full circle about the vertical axis. If this is not the case, the level should be adjusted as follows:

1. Turn the instrument until the bubble displacement from center is at a maximum.
2. Using the tribrach foot screws, bring the bubble halfway back to center.
3. Using the three or four small screws supporting the circular level, adjust the bubble until it is centered. Each screw is adjusted by slipping an adjusting pin through the screw hole and turning it so as to maintain downward pressure on the base washer. Do not adjust by depressing one screw and retracting another. If the limit of downward motion is reached on the screw being turned, retract all the screws and start adjusting them again. Do not force the level vial against its base.
4. Rotate the instrument slowly through a full circle. If the center of the bubble does not stay within 0.2 mm (0.01 in) of the center of the level vial, repeat the entire adjustment procedure.

Parallax adjustment. Before observing with the instrument, the observer should check for parallax. Parallax results when the focused image of an object does not lie on the same focal plane as the focused image of the reticle lines. To test for this, point the instrument at the sky or at a distant light-colored surface. Focus the ocular so the lines appear sharp and black, without straining the eye. Then, focus the objective on the scale of a leveling rod about 40 m (130 ft) away, and move the eye up and down, slowly, across the ocular. If the lines appear to move over the rod graduations, parallax is present. To eliminate the parallax, refocus the objective until no parallax is evident. If the image of the graduations is not distinct, focus the ocular by the small amount necessary to make it appear distinct.

Making an observation After setting up and leveling the instrument, the observer should point it quickly at the appropriate leveling rod. With most instruments

this is done by sighting along the top of the telescope. Since the observer stands at the side of the NI 002, in this case the system of prisms on the front of the instrument is used to line it up with the rod. Once the instrument is roughly pointed, the rod is observed through the telescope and the tangent screw is turned to align the image of the rod scale with the reticle lines.

The reticle normally includes a single vertical line with three horizontal lines crossing it. The top and bottom stadia lines are used to measure sighting distance. The longer, middle line defines the horizontal line of sight. When leveling with scales having block graduations, a straight line is sufficient. However, with scales having line graduations, the reticle should include a pair of divergent lines, the wedge, marked to one side in lieu of the middle line. The wedge (fig. 3-38) is a more sensitive tool for precisely intercepting a graduation. There are two ways to use it.

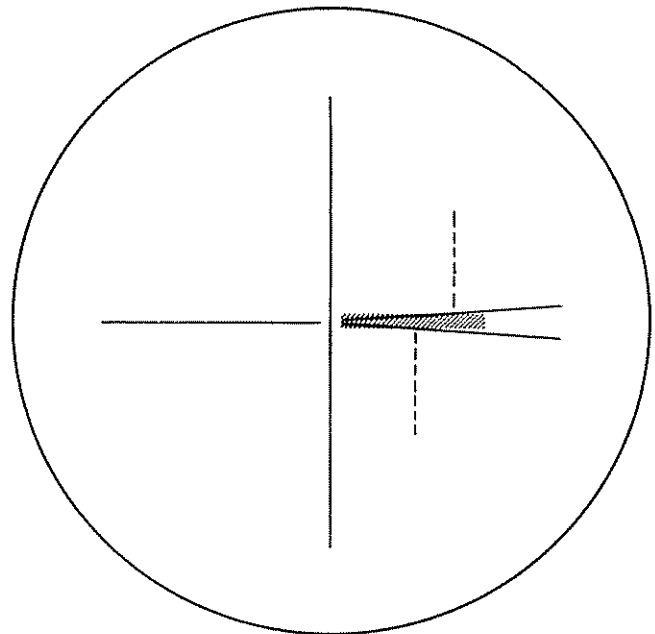
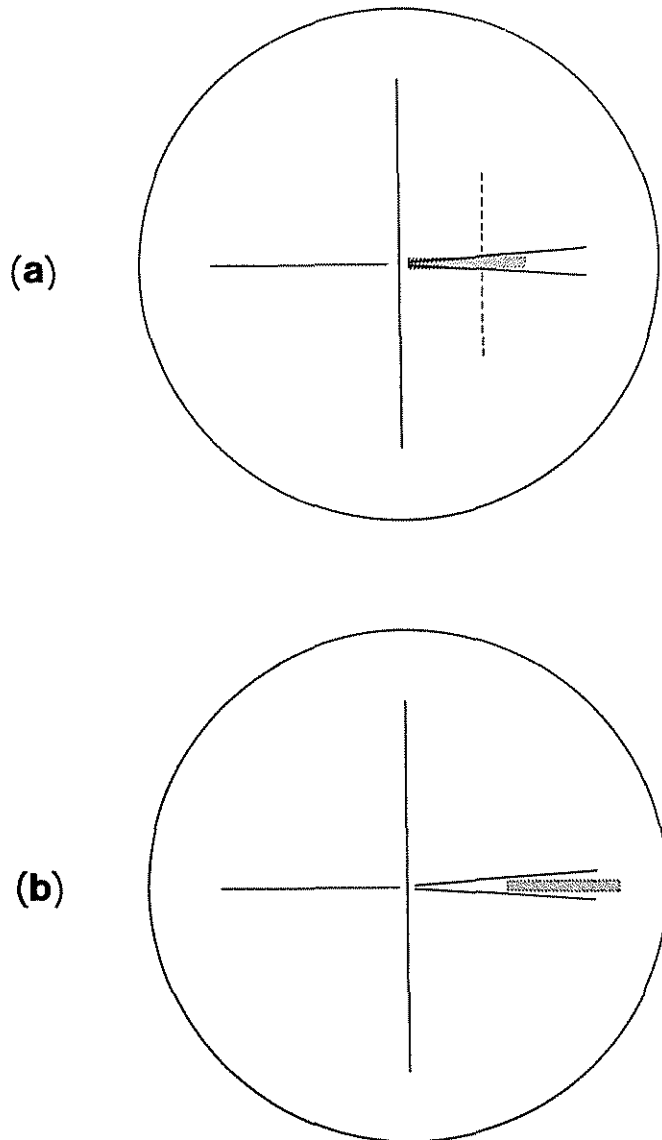

Figure 3-38.—Wedge reticle, graduation not centered.

In one method, set the wedge so the intersections of the upper and lower wedge-lines with the upper and lower edges of the graduation appear in vertical alignment (fig. 3-39a). In the second method, set the wedge so the interior edges of the wedge lines appear to just touch the corners of the end of the graduation (fig. 3-39b). Always make the final setting by turning the micrometer knob in the same direction.

In wind or on a vibrating surface, such as a bridge, it may be difficult to intercept a graduation precisely. If the vibration of the instrument is short in period, set the wedge so it appears to vibrate an even amount above and below the graduation. If the vibration is long in period or includes more than one graduation interval, mean the readings from a series of pointings to make each observation. If satisfactory results cannot be obtained, return to the section under better observing conditions.



Figures 3-39a. & 3-39b.—Wedge reticle, graduation centered.

Instrument maintenance. Before putting the instrument away each day gently wipe it with a clean soft cloth to remove dust and moisture. If the instrument has been exposed to rain or mist, it should also be allowed to stand at room temperature overnight. If the instrument is dirty or greasy, or if it has been exposed to salt water, clean all nonglass surfaces with a cloth dampened in denatured alcohol. Dust the objective and ocular lightly with a lens brush. Then, if necessary, wipe the lenses with lens paper that has been moistened with a small amount of lens cleaning solution. Care must be taken not to scratch the glass surfaces.

The instrument, with the lens cap attached, should be stored securely in a specially designed padded case. To protect the instrument from jolts and vibrations while the truck is in transit, the instrument should either be (1) carried in a foam-lined box bolted to the truck bed, (2) stored in its case and held on the lap of a passenger

in the truck, or (3) strapped onto an empty seat in the truck. If the instrument is to be shipped to another location, it should be packed in its case and placed inside a well-padded carton, with an appropriate warning label affixed on the outside of the package.

At least once every 18 months, the instrument should be cleaned and adjusted on a collimator by a qualified technician.

Shipment of the NI 002. The National Geodetic Survey has found the objective assembly of the NI 002 to be particularly vulnerable to vibration during shipment. Damage to the stop at the base of the assembly can be recognized by the inability of the user to read a full scale on the micrometer when the instrument is leveled. If the stop has been damaged, the instrument should not be used until it is repaired.

To prevent damage to the stop, screw a small, hard-rubber plug into the instrument to limit movement of the assembly during shipment (fig. 3-21). The plug should be screwed in whenever the NI 002 is transported for long distances in a leveling truck or shipped via commercial carrier.

3.3.6 Sighting Distance

The sighting distance between the instrument and a leveling rod is normally computed by the stadia method. To use the method, a full or half stadia interval must be computed from stadia readings made while observing. To balance the sighting distances of awkward setups quickly, before any observations are recorded, the stadia interval may also be determined by counting the number of rod units observed between the stadia lines (full interval) or between the middle line and one stadia line (half interval).

Derivation of the stadia method. By the stadia method, short distances may be measured with a precision of ± 0.2 m (± 0.7 ft). The stadia method has been widely used for topographic surveys and is routinely used in geodetic leveling to measure sighting distances and control the imbalance between backsights and foresights.

Figure 3-40 illustrates the relationships which exist between the leveling rod, the objective, and the reticle when a stadia measurement is made with a leveled instrument. For the focused instrument, the distance, D_i , from the objective to the reticle, and the distance, D_o , from the objective to the rod, are governed by the Law of Conjugate Foci, where the focal length, f , of the objective, f , is a constant:

$$(1/D_o) + (1/D_i) = 1/f.$$

The sighting distance, s , is equal to D_o plus the fixed distance, c , between the objective and the vertical axis of the instrument. By solving for D_o and adding c :

$$s = f \times (D_o / D_i) + f + c.$$

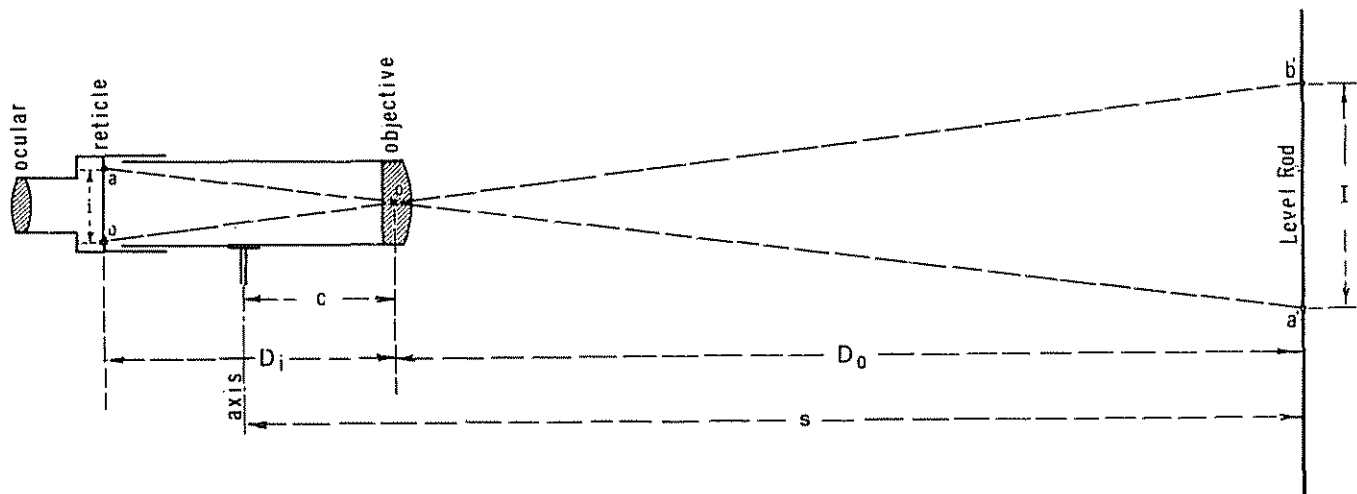

Figure 3-40.—Relationship of stadia interval to sighting distance.

To a sufficient approximation, the line connecting points a and a' is a straight line through point o ; therefore, triangles abo and $a'b'o$ are similar. Thus, all corresponding dimensions are in the ratio $D_o:D_i$, including the full stadia interval, I , and the distance, i , between the upper and lower stadia lines in the reticle:

$$D_o/D_i = I/i.$$

By substituting the known ratio for the unknown:

$$s = (f/i) \times I + f + c.$$

The ratio, f/i , is unique for the instrument and is called the stadia factor ("multiplication constant"). The constant, $f+c$, is also unique for the instrument and is called the stadia constant ("addition constant"). In most instruments with internal-focusing telescopes, the optical system is so designed that the stadia constant is essentially zero for the sighting distances used in leveling. Table 3-2 shows stadia factors and constants for some typical instruments.

Computing sight distance. From the full stadia interval, I , the sighting distance, s , is computed by the formula just derived:

$$s = (I \times \text{stadia factor}) + \text{stadia constant}.$$

For practical use in the field, the stadia constant is usually neglected. However, it should not be neglected when determining the stadia factor. During these operations sighting distance must be determined as accurately as possible. However, during routine leveling the error resulting from neglecting the stadia constant is insignificant when compared to the overall error of the stadia method.

To obtain the sighting distance in meters, a conversion factor must be included in the formula. Since the stadia factor is a unitless quantity and the stadia interval is measured in rod units (ru), the conversion factor required is the number of meters per rod unit. Thus:

$$s_m = I_{ru} \times \text{conversion factor}_{m/ru} \times \text{stadia factor}.$$

In the past, the product of the stadia factor and the rod-unit conversion factor has been referred to as the "stadia constant." Do not confuse such usage of the term with the definition given here.

This formula applies in three-wire leveling and whenever the full interval between the stadia lines is computed. For example, if the instrument has a stadia factor of 100 and the rod units are centimeters,

$$s_m = I_{cm} \times 0.01_{m/cm} \times 100 = I.$$

Thus a convenient relationship is derived: the number of rod units in the full stadia interval equals the sighting distance in meters.

However, if the rod units are in half-centimeters (hcm), the formula becomes

$$s_m \times I_{hcm} \times 0.005_{m/hcm} \times 100 = I/2.$$

In micrometer leveling, this result is employed to reduce the number of readings necessary. Instead of reading the intercepts of all three lines, only those of the wedge and one stadia line (usually the lower) are read. The difference of the readings is half of the stadia interval. As long as the rod units are half-centimeters, the difference of the readings is equal to the sighting distance. When using the micrometer-leveling procedure with centimeter rods, the half stadia interval must be multiplied by two to obtain the correct sighting distance.

Determining the stadia factor. The stadia factor is set by the instrument manufacturer for converting the stadia interval to sighting distance. In modern instruments used for geodetic leveling the stadia factor is typically 100. The reticle is etched in glass to ensure that the factor does not change. The stadia factor need not be determined in the field when using such an instrument.

Some older instruments may have a reticle consisting of fine strands of spider web, sandwiched between glass plates. The stadia factor for this type of instru-

ment should be determined in the field whenever it is put to use and whenever the reticle is changed. To determine the stadia factor:

1. Lay out a course in a straight line along a level track, roadway, or sidewalk, marking the distances at 0, 25, 35, 45, 55, 65, and 75 m.

2. Position the instrument to allow for its stadia constant. For example, the Wild N3 has a stadia constant of -0.2 m; therefore, it should be set forward of the zero stake by 0.2 m. An instrument with a positive stadia constant should be set back from the zero stake by the corresponding amount.

3. Level the instrument. Read the low scale of a leveling rod at each of the six distances. Read all three reticle lines, top to bottom, at each distance.

4. Record the readings and identifying information as shown in figures 3-41 and 3-42, using the recording form appropriate to the type of leveling to be done. Compute each half-stadia interval.

5. Total the half-stadia intervals (in rod units). Total the measured distances (in meters) and divide by the total of the half-stadia intervals. The value obtained is the stadia factor, expressed in meters per rod unit, for the instrument-rod combination used.

6. The result of step 5 should be checked by computing a similar value for each distance. Divide each measured distance by the sum of the two half-stadia intervals at that distance. The mean of these six values should agree with the value computed in step 5.

7. To obtain the stadia factor of the instrument, independent of rod units, the value expressed in meters per rod unit must be multiplied by a conversion factor. This factor is the number of rod units per meter.

8. Submit data for the stadia factor measurement to the project office, along with other leveling data for the day.

3.3.7 Collimation Check

Under field conditions the collimation error of a leveling instrument (sec. 3.1.2, "Leveling instrument") is measured by obtaining a set of observations called the collimation check ("C-shot" or "peg test"). Collimation error is limited by adjustment of the instrument. Because the adjustment can change easily under field conditions, thus changing the collimation error, make the collimation check at least once a day with most instruments. In addition, make the check any time that an instrument sustains a severe shock or seems to function abnormally.

The collimation check has two purposes: to prove that the instrument is properly adjusted within the standard of accuracy required for the survey and to provide a collimation factor with which to correct data from unbalanced setups.

Collimation factor. During the collimation check the angular value of collimation error is not measured directly. Instead, the tangent of the angle, called the collimation factor (C-factor or C) is computed. A derivation of the formula follows.

Two elevation differences are observed in the same direction, but with different setups, between the same two turning points. Each setup has an imbalance of sighting distances. Since the elevation differences measured between the same two points should be equal, any difference between them is the result of the effects of collimation error, pointing error, refraction, and curvature.

The collimation error, α , causes an error that is proportional to the imbalance, Δs , in each setup:

$$\tan \alpha \times \Delta s = C \times \Delta s.$$

The pointing error is limited by a reading check. The sum, e , of refraction and curvature error is mathematically predicted for the appropriate sighting distances in each setup. Hence, if each observed elevation difference, Δh , is corrected for these errors,

$$\Delta h_2 - (C \times \Delta s_2) - e_2 = \Delta h_1 - (C \times \Delta s_1) - e_1.$$

Solving for the collimation factor,

$$C = [(\Delta h_1 - e_1) - (\Delta h_2 - e_2)] / (\Delta s_1 - \Delta s_2).$$

If the first setup is balanced and the second unbalanced (as for "Kukkamaki's method," given later in this subchapter, $\Delta s_1 = 0$ and $e_1 = 0$,

$$C = [\Delta h_1 - (\Delta h_2 - e_2)] / (-\Delta s_2)$$

If both setups are unbalanced by the same amount, and they are leveled in opposite directions (as for the "10-40 method," given later in this subchapter), the corrected elevation differences are opposite in sign. Thus,

$$C = [(\Delta h_1 - e_1) + (\Delta h_2 - e_2)] / (\Delta s_1 - \Delta s_2).$$

Since $\Delta s_1 = \Delta s_2$ and $e_1 \cong e_2$, the formula is simplified to the following:

$$C = [(\Delta h_1 + \Delta h_2) - 2e] / 2\Delta s.$$

The elevation differences, the refraction and curvature errors, and the imbalances are measured in the same units; the resulting collimation factor is dimensionless. However, for convenience, it is usually expressed in millimeters per meter:

$$C_{\text{mm/m}} = \tan \alpha \times 1000_{\text{mm/m}}$$

For an instrument with a reversible compensator, a separate collimation factor may be computed for each position of the compensator. The collimation factor for the instrument is the mean,

$$C = (C_1 + C_2) / 2.$$

If the collimation factor is not within the tolerance for the survey, the instrument must be adjusted. When the adjustment can be made in the field, the amount of

| NOAA FORM 74-191 (4-77) | | | | | | | | | | U. S. DEPARTMENT OF COMMERCE NATIONAL OCEANIC AND ATMOSPHERIC ADMINISTRATION | | PAGE | |
|---|----------------|--------------|-----------|-----------|-----------------------|-------------------|----------------|------------|----------------|--|-------------|--------|------------|
| GEODETTIC LEVELING MICROMETER OBSERVATIONS (Δh) | | | | | | | | | | STADIA FACTOR EXAMPLE | | 1 OF 1 | |
| STATION | YR. | MO. | DAY | CODE | INSTRUMENT SERIAL NO. | CODE | ROD SERIAL NO. | CODE | ROD SERIAL NO. | TIME | TEMPERATURE | W. S. | OD. SERVER |
| 1 | 8 | 0 | 7 | 28 | 217 | | 608134 | 3116 | 277890 | | 27.1 | 27.5 | 2 |
| FROM | BM DESIGNATION | | | | TO | BM DESIGNATION | | | | TIME | TEMPERATURE | W. S. | OD. SERVER |
| | | | | | | | | | | 27.1 | 27.5 | 2 | CWS |
| SET UP | UPPER STADIA | LOWER STADIA | LOW SCALE | BACK/FORE | ΔL | HIGH SCALE | BACK/FORE | ΔH | ΔH | REMARKS | | | |
| 25 | 40.10 | 25.0376.0 | 25.0 | B | | | | | | 25 50.0 = 0.500 | | | |
| | 37.6.0 | 35.1.0 | | F | | | | | | | | | |
| 35 | 41.1.1 | 35.1376.0 | 35.0 | B | | | | | | 35 70.1 = 0.499 | | | |
| | 37.6.0 | 60.134.0 | 60.0 | F | | | | | | | | | |
| 45 | 42.0.0 | 45.0375.0 | 44.9 | B | | | | | | 45 89.9 = 0.501 | | | |
| | 37.5.0 | 105.1330.1 | 104.9 | F | | | | | | | | | |
| 55 | 43.1.0 | 55.0376.0 | 55.0 | B | | | | | | 55 110.0 = 0.500 | | | |
| | 37.6.0 | 160.132.0 | 159.9 | F | | | | | | | | | |
| 65 | 44.0.0 | 65.0375.0 | 65.0 | B | | | | | | 65 130.0 = 0.500 | | | |
| | 37.5.0 | 225.1310.0 | 224.9 | F | | | | | | | | | |
| 75 | 45.1.0 | 75.0376.0 | 75.0 | B | | | | | | 75 150.0 = 0.500 | | | |
| | 37.6.0 | 300.1301.0 | 299.9 | F | | | | | | | | | |
| 300 m | | | | | 5600.0 hcm | 300/600.0 = 0.500 | | | | MEAN 0.500 | | | |
| CHECK | | | | | | | | | | 0.500 m/hcm x 200 hcm/m = 100 | | | |

Figure 3-41.—Stadia factor determination, micrometer procedure, half-centimeter rods.

| NOAA FORM 74-187 (4-77) | | | | | | | | | | U. S. DEPARTMENT OF COMMERCE NATIONAL OCEANIC AND ATMOSPHERIC ADMINISTRATION | | PAGE | | | | | | |
|--|----------------|--------|-------|------|-----------------------|----------------|----------------|-------|----------------|--|-------------|--------|------------|-------------|----------------|----------------|-------|---|
| GEODETTIC LEVELING THREE-WIRE OBSERVATIONS | | | | | | | | | | STADIA FACTOR EXAMPLE | | 1 OF 1 | | | | | | |
| STATION | YR. | MO. | DAY | CODE | INSTRUMENT SERIAL NO. | CODE | ROD SERIAL NO. | CODE | ROD SERIAL NO. | TIME | TEMPERATURE | W. S. | OD. SERVER | | | | | |
| 1 | 8 | 0 | 7 | 28 | 217 | | 30150 | 312 | 1305 | | 28.0 | 28.5 | 2 | | | | | |
| FROM | BM DESIGNATION | | | | TO | BM DESIGNATION | | | | TIME | TEMPERATURE | W. S. | OD. SERVER | | | | | |
| | | | | | | | | | | 28.0 | 28.5 | 2 | CWS | | | | | |
| BACKSIGHT | | | | | FORESIGHT | | | | | COMMENT | | | | | | | | |
| SET UP | UPPER | MIDDLE | LOWER | MEAN | BACK CENTER | S _U | S _L | (U+L) | Σ | UPPER | MIDDLE | LOWER | MEAN | BACK CENTER | S _U | S _L | (U+L) | Σ |
| | | | | | | | | | | | | | | | | | | |
| 25 | 133.7 | 130.0 | 126.2 | | | 3.7 | | | | | | | | | | | | |
| | | | | | | 3.8 | | 7.5 | | | | | | 25 | | | | |
| | | | | | | | | | | | | | | 7.5 | | | | |
| | | | | | | | | | | | | | | | | | | |
| 35 | 155.9 | 150.7 | 125.4 | | | 5.2 | | | | | | | | | | | | |
| | | | | | | 5.3 | | 10.5 | | | | | | 35 | | | | |
| | | | | | | | | 18.0 | | | | | | 10.5 | | | | |
| | | | | | | | | | | | | | | | | | | |
| 45 | 137.7 | 131.0 | 124.2 | | | 6.7 | | | | | | | | | | | | |
| | | | | | | 6.8 | | 13.5 | | | | | | 45 | | | | |
| | | | | | | | | 31.5 | | | | | | 13.5 | | | | |
| | | | | | | | | | | | | | | | | | | |
| 55 | 132.5 | 124.3 | 116.0 | | | 8.2 | | | | | | | | | | | | |
| | | | | | | 8.3 | | 16.5 | | | | | | 55 | | | | |
| | | | | | | | | 48.0 | | | | | | 16.5 | | | | |
| | | | | | | | | | | | | | | | | | | |
| 65 | 126.2 | 116.5 | 106.8 | | | 9.7 | | | | | | | | | | | | |
| | | | | | | 9.7 | | 19.4 | | | | | | 65 | | | | |
| | | | | | | | | 67.4 | | | | | | 19.4 | | | | |
| | | | | | | | | | | | | | | | | | | |
| 75 | 121.8 | 110.6 | 099.4 | | | 11.2 | | | | | | | | | | | | |
| | | | | | | 11.2 | | 22.4 | | | | | | 75 | | | | |
| | | | | | | | | 89.8 | | | | | | 22.4 | | | | |
| 300 m | | | | | 300 | 89.8 = 3.34 | | | | MEAN = 3.34 x 100 cm/m = 334 | | | | | | | | |
| CHECK | | | | | | | | | | | | | | | | | | |

Figure 3-42.—Stadia factor determination, three-wire procedure, centimeter rods.

error to be removed is computed from the following formula. It is referred to the rod at the farthest sighting distance, s_F , and computed in rod units:

$$\text{error}_F = s_F \times C_{mm/m} \times \text{conversion factor}_{ru/mm}$$

The error is subtracted from the last reading made on the far rod. Then the instrument is adjusted in such a way that the corrected reading is observed. After performing the adjustment, the entire procedure is repeated to compute and check the new collimation factor.

Note that the collimation-correction factor, "C", commonly used to correct data from three-wire leveling, is not equal to the collimation factor defined here. In the past, "C" has been defined as the product of the stadia factor and the tangent of the collimation error. The imbalance—expressed in rod units as a stadia interval, not as a distance—could be multiplied directly by "C" to obtain the correction for collimation error in rod units. Modern instruments and rods make this practice unnecessary, since they usually provide a one-to-one correspondence between stadia interval and distance.

General instructions. Two methods, sufficiently precise to satisfy the purposes of the collimation check, are presented here. The accuracy of the result with either of these methods depends on the assumption that the error observed is entirely a function of collimation error. Other effects that alter the line of sight, such as refraction, must be controlled. To achieve this, perform the following:

1. Make the collimation check on uniformly flat ground. The slope should be no more than 2 percent.
2. Allow the instrument and leveling rods to acclimatize for 5 minutes or more, if they have just been removed from their cases.
3. Make sure that the circular levels on the instrument and the rods are properly adjusted. (See secs. 3.3.5, "Circular-level adjustment" and 3.4.3, "Checking the circular level.")
4. Correct for refraction and curvature at each sighting distance. To use the values for refraction and curvature given in table 3-3, the collimation check should be made, if possible, when the air-temperature differential is less than 1°C (2°F) in magnitude and negative in sign (sec. 3.6.1). However, make a check immediately following an accident to determine if the instrument has been damaged, regardless of the atmospheric conditions. Then, make another check as soon as the conditions are suitable.

Kukkamaki's method. T. J. Kukkamaki of the Finnish Geodetic Institute developed this method for making a collimation check. The following instructions apply to any combination of instrument and rods. If the instrument does not have a reversible compensator, ignore references to compensator's position. Record the data either on a standard recording form for leveling or into a computer.

Table 3-3.—Refraction and curvature errors in a single sight

| Sighting distance, s | | Error in a rod reading, e | |
|------------------------|---------|-----------------------------|-------|
| (m) | (ft) | (mm) | (ft) |
| 0 to 28 | 0 to 92 | 0.0 | 0.000 |
| 28 48 | 92 157 | 0.1 | 0.000 |
| 48 61 | 157 200 | 0.2 | 0.001 |
| 61 73 | 200 240 | 0.3 | 0.001 |
| 73 82 | 240 269 | 0.4 | 0.001 |
| 82 91 | 269 299 | 0.5 | 0.002 |
| 91 99 | 299 325 | 0.6 | 0.002 |
| 99 106 | 325 348 | 0.7 | 0.002 |
| 106 113 | 348 371 | 0.8 | 0.003 |
| 113 119 | 371 390 | 0.9 | 0.003 |
| 119 125 | 390 410 | 1.0 | 0.003 |
| 125 131 | 410 430 | 1.1 | 0.004 |
| 131 137 | 430 449 | 1.2 | 0.004 |
| 137 142 | 449 466 | 1.3 | 0.004 |
| 142 147 | 466 482 | 1.4 | 0.005 |
| 147 150 | 482 492 | 1.5 | 0.005 |
| 160 | 525 | 1.8 | 0.006 |
| 170 | 558 | 2.1 | 0.007 |
| 180 | 591 | 2.3 | 0.008 |
| 190 | 623 | 2.6 | 0.009 |
| 200 | 656 | 2.8 | 0.009 |
| 210 | 689 | 3.0 | 0.010 |
| 220 | 722 | 3.3 | 0.011 |
| 230 | 755 | 3.7 | 0.012 |
| 240 | 787 | 4.0 | 0.013 |
| 250 | 820 | 4.3 | 0.014 |
| 260 | 853 | 4.7 | 0.015 |
| 270 | 886 | 5.0 | 0.016 |
| 280 | 919 | 5.4 | 0.018 |
| 290 | 951 | 5.8 | 0.019 |
| 300 | 984 | 6.2 | 0.020 |

1. On the flattest possible ground, lay out a setup with precisely 20 m between the turning points. Position the instrument in line between them, precisely 10 m from each turning point. (Use a tape to measure these distances.) (See fig. 3-43.)

2. As indicated on the recording form (line *40*), enter the date, instrument code and serial number, rod codes and serial numbers, time and time zone, type of temperature units, beginning air temperature, wind and sun codes, and the initials of the observer, recorder, and rodmen. Check all serial numbers against the equipment actually used. Label the recording form "Collimation Check." (See figs. 3-44 through 3-46 for examples.)

3. **FIRST SETUP:** Level the instrument. Check that the circular levels on the instrument and the rods are properly adjusted. Observe and record a set of readings by either the micrometer or three-wire procedure. Use rod 1 as the backsight, and be sure to change the compensator's positions between the low- and high-scale readings. Check that the imbalance is no more than ± 0.4 m. The reading check for the micrometer procedure should be ± 0.25 mm (± 0.05 hcm for half-centimeter rods).

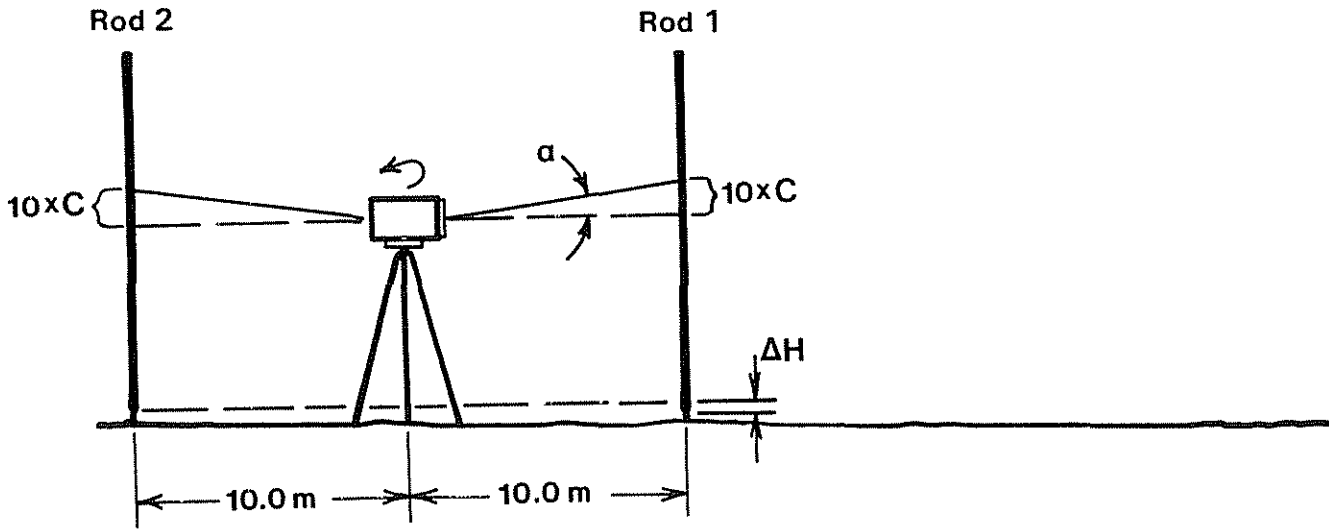

First setup

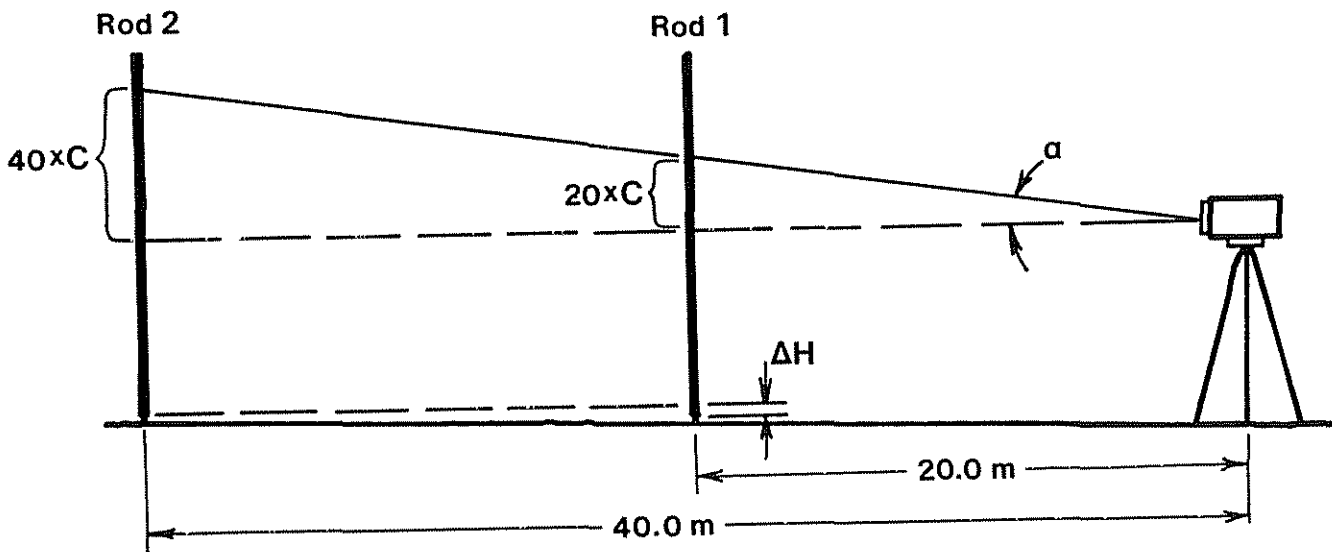

Second setup

Figure 3-43.—Collimation check, Kukkamaki's method.

4. SECOND SETUP: Position the instrument in line with the turning points, 20 m from rod 1. Put the compensator in position one. With rod 1 as the backsight, observe and record another set of readings; however, leave the compensator in position one throughout the setup. Check that the magnitude of the imbalance is between 19.6 and 20.4 m. Enter the ending temperature. Remain in position until the collimation factor has been checked.

5. Convert the elevation differences, Δh_2 and Δh_1 , from rod units to millimeters. Compute or obtain from table 3-3 the values, e , for refraction and curvature error at the sighting distances of the second setup, 20 and 40 m. Compute C , in millimeters per meter, by the formula:

$$C = [(\Delta h_1 - \Delta h_2 + (e_{20} - e_{40}))] / -\Delta s_2$$

If the instrument has a reversible compensator, label the value "C₁" and skip to step 11.

6. Compare C with the tolerance (table 3-1). If the tolerance is exceeded, then adjust the instrument as follows.

7. ADJUSTMENT: Compute the error, in rod units, resulting from collimation error in the reading made at 40 m:

$$\text{error}_{ru} = 40 \times C_{mm/mm} \times \text{conversion factor}_{ru/mm}$$

For half-centimeter rods, the error is $8 \times C$. For centimeter rods, it is $4 \times C$. Subtract this from the foresight reading, obtained on rod 2 (high scale) during the second setup. The result is the correct reading after adjusting the instrument.

8. Refer to the instrument manual for the mechanics of adjusting the instrument. Many compensator instruments have a setscrew on the front of the telescope that is loosened, after which a wedge-shaped lens is rotated to correct the angle of the line of sight.

9. Still in position for the second setup, point toward rod 2 (high scale) and adjust the instrument until the line of sight intercepts the corrected reading.

10. Return to the first setup (step 3) and repeat the entire collimation check to compute and check the new collimation factor.

11. THIRD SETUP (reversible compensator only): Put the compensator in position two and follow the same procedure as for the second setup (step 4). Compute C₂ by the same formula as C₁.

13. Compute the mean collimation factor and record it:

$$C = (C_1 + C_2) / 2.$$

Check this against the tolerance for instruments with reversible compensators (table 3-1).

14. Compute the Q-factor and record it:

$$Q = C_1 - C_2.$$

Check this against the tolerance (table 3-1).

15. If the tolerances in step 13 is exceeded, the collimation check should be repeated to verify the original observations. If the tolerances are still exceeded, return the instrument to the repair shop or factory for adjustment.

10-40 method. Another procedure for the collimation check is called the 10-40 method because each setup is unbalanced, with one rod positioned 10 m away from the instrument and the other 40 m away. The following instructions apply to any combination of instrument and rods. Record the data either on a standard recording form for leveling, or into a computer.

| NGAA FORM 74-191 (8-77) | | | | | | | | | | U.S. DEPARTMENT OF COMMERCE NATIONAL OCEANIC AND ATMOSPHERIC ADMINISTRATION | | | | | | | | | | PAGE | | | |
|--|-------------|---------------|-------------|------------------|---------------------|-----------------------|----------------------|------------|------------|--|--|-------------------|--|----------------|--|---------------|--|-------------|--|------|--|-----------|--|
| GEODETTIC LEVELING MICROMETER OBSERVATIONS (Δh) | | | | | | | | | | | | COLLIMATION CHECK | | Z | | TIME | | | | | | | |
| * 4 0 * | | YR. / NO. DAY | | CODE | | INSTRUMENT SERIAL NO. | | H CODE | | ROD SERIAL NO. | | CODE | | ROD SERIAL NO. | | EXAMPLE | | | | | | | |
| | | 8011015 | | 233 | | 456511H | | 316 | | 1456923 | | 16 | | 145694 | | | | | | | | | |
| FROM | | | | BM DESIGNATION | | | | TO | | | | BM DESIGNATION | | | | TIME | | TEMPERATURE | | WIND | | OB-SERVER | |
| | | | | KUKKAMÄKI METHOD | | | | | | | | | | | | R/10/10/1030C | | 1/0/1/0/02 | | 045 | | | |
| SET UP | STADIA BACK | SP | STADIA FORE | SP | LOW SCALE BACK/FORE | Δh | HIGH SCALE BACK/FORE | Δh | Δh | Δh | REMARKS | | | | | | | | | | | | |
| 1 | 287! | 9.6 | 269! | 9.6 | 287:82 | 18:13 | 88043 | - | 290 | +03 | $\Delta h_1 =$ | | | | | | | | | | | | |
| | 2774 | | 2594 | | 269:69 | | 88333 | | | | +18.115 | $T_1 = 10.1$ | | | | | | | | | | | |
| | | | | | | | | | | | $\Delta s_1 = 0.0$ | | | | | | | | | | | | |
| 2 | 259! | 19.7 | 240! | 19.7 | 259:19 | 18:25 | 85168 | - | 276 | +01 | $\Delta h_2 =$ | | | | | | | | | | | | |
| | 2393 | | 2004 | | 240:94 | | 85444 | | | | +18.245 | $T_2 = 10.6$ | | | | | | | | | | | |
| | | | | | | | | | | | $s_1 - s_2 = -\Delta s_1 = 19.9$ m | | | | | | | | | | | | |
| | | | | | | | | | | | $C_1 = -0.043$ mm/m | | | | | | | | | | | | |
| | | | | | | | | | | | 5 mm/kcm | | | | | | | | | | | | |
| | | | | | | | | | | | -0.650 mm $\Delta h_1 - \Delta h_2$ | | | | | | | | | | | | |
| | | | | | | | | | | | +0.200 mm $e_{20} - e_{40}$ | | | | | | | | | | | | |
| | | | | | | | | | | | -0.850 mm | | | | | | | | | | | | |
| | | | | | | | | | | | 19.9 m $-\Delta s_2$ | | | | | | | | | | | | |
| | | | | | | | | | | | $C_2 =$ | | | | | | | | | | | | |
| | | | | | | | | | | | | | | | | | | | | | | | |
| 3 | 259! | 19.7 | 241! | 19.7 | 259:43 | 17:91 | 85193 | - | 308 | -01 | $\Delta h_3 =$ | | | | | | | | | | | | |
| | 2393 | | 2014 | | 241:52 | | 85501 | | | | +17.915 | $T_3 = 10.1$ | | | | | | | | | | | |
| | | | | | | | | | | | $s_2 - s_3 = -\Delta s_2 = 19.9$ m | | | | | | | | | | | | |
| | | | | | | | | | | | $C_3 = +0.040$ mm/m | | | | | | | | | | | | |
| | | | | | | | | | | | 5 mm/kcm | | | | | | | | | | | | |
| | | | | | | | | | | | +1.000 mm $\Delta h_1 - \Delta h_3$ | | | | | | | | | | | | |
| | | | | | | | | | | | +0.200 mm $e_{20} - e_{40}$ | | | | | | | | | | | | |
| | | | | | | | | | | | +0.800 mm | | | | | | | | | | | | |
| | | | | | | | | | | | 19.9 m $-\Delta s_3$ | | | | | | | | | | | | |
| | | | | | | | | | | | $C_4 =$ | | | | | | | | | | | | |
| | | | | | | | | | | | | | | | | | | | | | | | |
| | | | | | | | | | | | $C = \frac{-0.043 + 0.040}{2} = -0.002$ mm/m | | | | | | | | | | | | |
| | | | | | | | | | | | $Q = \frac{-0.043 - 0.040}{5} = -0.017$ mm/m | | | | | | | | | | | | |

Figure 3-44.—Collimation check, Kukkamaki's method, micrometer procedure, half-centimeter rods, reversible compensator.

| NOAA FORM 76-191 18-771 | | | | | | | | | | U.S. DEPARTMENT OF COMMERCE NATIONAL OCEANIC AND ATMOSPHERIC ADMINISTRATION | | PAGE | |
|---|------------------|----------------|----------------|----------------|-----------------------|--------------|----------------------|-----------------|--------------|--|-------------------|--------|------|
| GEODETIC LEVELING MICROMETER OBSERVATIONS (Δh) | | | | | | | | | | | | 1 of 1 | |
| * 40 | YR. | MO. | DAY | CODE | INSTRUMENT SERIAL NO. | M | CODE | ROD SERIAL NO. | CODE | ROD SERIAL NO. | COLLIMATION CHECK | Z | TIME |
| * 41 | 80 | 10 | 16 | 231 | 58021H | 316 | | 148972 | 316 | 149774 | EXAMPLE | | |
| FROM | BM DESIGNATION | TO | BM DESIGNATION | Z | TIME | TEMPERATURE | WIND | ON-SERVER | | | | | |
| | KUKKAMAKI METHOD | | | | 101901 | 0925 | 15 | 11 | 11 | | | | |
| SET UP | STADIA BACK | S ₁ | STADIA FORE | S ₂ | LOW SCALE BACK/FORE | Δh_1 | HIGH SCALE BACK/FORE | Δh_{H4} | Δh_L | REMARKS | | | |
| 1 | 309 | 10.0 | 317 | 10.0 | B 309.24 | - 8.22 | B 901.72 | - 29.24 | +102 | Δh_1 | | | |
| | 299.0 | | 307.0 | | F 317.46 | | F 930.96 | | | - 8.230 | | | |
| $\Delta s_1 = 0.0$ m | | | | | | | | | | | | | |
| 2 | 279 | 19.8 | 297 | 40.0 | B 279.92 | - 8.02 | B 872.40 | - 29.06 | +104 | Δh_2 | | | |
| | 259.2 | | 247.0 | | F 287.94 | | F 901.46 | | | - 8.040 | | | |
| $\Delta s_2 = 20.2$ m | | | | | | | | | | | | | |
| | | | | | | | | | | - 0.190 hcm | | | |
| | | | | | | | | | | 5 mm/hcm | | | |
| | | | | | | | | | | - 0.950 mm $\Delta h_1 - \Delta h_2$ | | | |
| | | | | | | | | | | + 0.200 mm $e_{20} - e_{40}$ | | | |
| | | | | | | | | | | - 1.150 mm | | | |
| | | | | | | | | | | 20.2 m $-\Delta s_2$ | | | |
| | | | | | | | | | | $C = -0.057$ mm/m | | | |
| | | | | | | | | | | To adjust: | | | |
| | | | | | | | | | | 8 | | | |
| | | | | | | | | | | - 0.46 hcm | | | |
| After adjustment: | | | | | | | | | | | | | |
| 1 | 312 | 10.0 | 320 | 9.9 | B 312.03 | - 8.26 | B 904.32 | - 29.24 | -102 | | | | |
| | 302.0 | | 310.1 | | F 320.29 | | F 933.56 | | | - 8.250 | | | |
| $\Delta s_1 = 0.1$ | | | | | | | | | | | | | |
| 2 | 282 | 20.0 | 290 | 40.0 | B 282.17 | - 8.23 | B 874.92 | - 29.24 | +101 | | | | |
| | 262.0 | | 250.0 | | F 290.40 | | F 904.16 | | | - 8.235 | | | |
| $\Delta s_2 = 20.0$ | | | | | | | | | | | | | |
| | | | | | | | | | | - 0.015 | | | |
| | | | | | | | | | | 5 | | | |
| | | | | | | | | | | - 0.075 | | | |
| | | | | | | | | | | + 0.200 | | | |
| | | | | | | | | | | - 0.275 | | | |
| | | | | | | | | | | 20.0 | | | |
| | | | | | | | | | | $C = -0.014$ | | | |

Figure 3-45.—Collimation check, Kukkamaki's method, micrometer procedure, centimeter rods, nonreversible compensator.

1. On the flattest possible ground, lay out a setup with precisely 50 m between the turning points. Position the instrument in line between them, precisely 10 m, as measured with a tape, from the turning point supporting rod 1. (See fig. 3-47.)

2. As indicated on the recording form (line *40*) enter the date, instrument code and serial number, rod codes and serial numbers, time and time zone, type of temperature units, beginning temperature, wind and sun codes, and the initials of the observer, recorder, and rodmen. Check all serial numbers against the equipment actually used. Label the form "Collimation Check." (See figs. 3-48 through 3-50 for examples.)

3. FIRST SETUP: Level the instrument. Check that the circular levels on the instrument and the rods are properly adjusted. Make a set of readings by the micrometer or three-wire procedure. Use rod 1 as the backsight. Check that the magnitude of the imbalance is between 29.6 and 30.4 m. The reading check for the micrometer procedure should be ± 0.25 mm (± 0.05 hcm for half-centimeter rods). Do not make the reading check if using a reversible compensator.

4. SECOND SETUP: Position the instrument in line between the turning points, precisely 10 m from rod 2. Make a set of readings as in step 3, using rod 2 as the backsight. Check the imbalance as in step 3. If using an instrument with a reversible compensator, check that

$$(\Delta h_L - \Delta h_H)_1 + (\Delta h_L - \Delta h_H)_2 \leq \pm 0.35 \text{ mm.}$$

The tolerance corresponds to ± 0.07 hcm for half-centimeter rods. (If this reading check is not satisfied, begin again at step 1.) Remain in position until the collimation factor has been checked.

5. Convert the elevation differences, Δh_2 and Δh_1 , from rod units to millimeters. Compute or obtain from table 3-3 the values, e , for refraction and curvature at 10 and 40 m. Compute the collimation factor, in millimeters per meter, by the following formula. Note that the imbalances are both negative.

$$C = [(\Delta h_1 + \Delta h_2) - 2(e_{10} - e_{40})] / (\Delta s_1 + \Delta s_2)$$

6. Check the collimation factor against the tolerance (table 3-1). If the tolerance is exceeded, then adjust the instrument as described in steps 7 through 10 of Kukkamaki's method.

7. If the tolerances in step 6 are exceeded, the collimation check should be repeated to verify the original observations. If the tolerances are still exceeded, return the instrument to the repair shop or factory for adjustment.

3.3.8 Compensation Check

When a compensator instrument is roughly leveled, the compensator should be freely suspended, unaffected by its suspension and damping mechanisms. The range

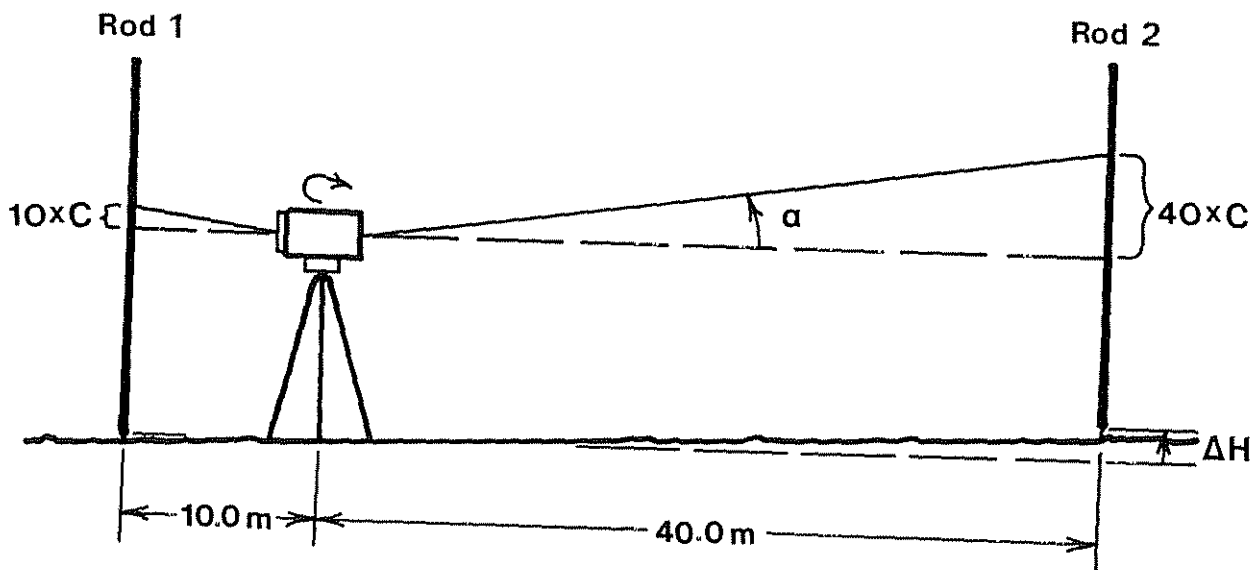

First setup

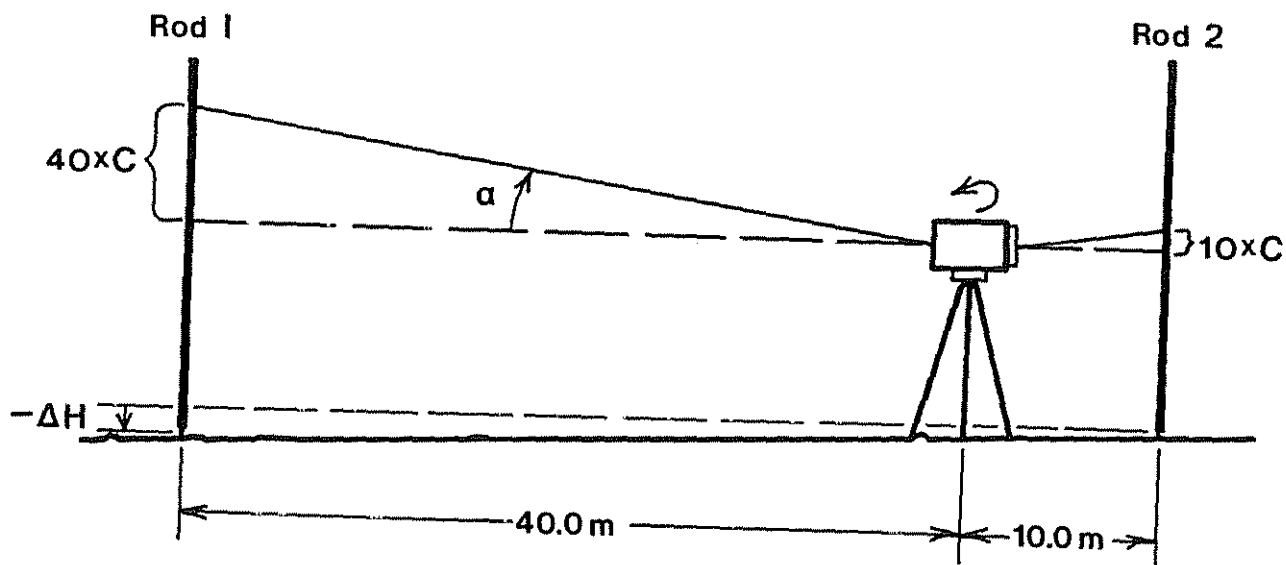

Second setup

Figure 3-47.—Collimation check, 10-40 method.

of arc in which the compensator is expected to suspend freely should be somewhat greater than the arc described by a 2-mm movement of the bubble in the circular level (Table 3-3 contains the sensitivities of the circular levels mounted on various instruments.) When the circular

level is properly adjusted the compensator should provide a line of sight having a consistent collimation error, within $1''0$ (0.00485 mm/m) of that measured during the collimation check, no matter in which direction the instrument is pointed.

| NOAA FORM 76-191 18-771 | | | | | | | | | | U.S. DEPARTMENT OF COMMERCE NATIONAL OCEANIC AND ATMOSPHERIC ADMINISTRATION | | | | | | | | | | PAGE 1 of 1 | | | | | | | |
|--|-------------|-------|-------------|----------------|---------------------|--------------|--------------|-----------------------|-----------------|--|---------|-----------------------------------|---------------------------------------|---------------------------------|--|----------------|--|-------------------|--|----------------|--|------|--|-----|--|-----------|--|
| GEODETTIC LEVELING MICROMETER OBSERVATIONS (Δh) | | | | | | | | | | | | | | | | | | | | | | | | | | | |
| A | | D | | YR. NO. DAY | | CODE | | INSTRUMENT SERIAL NO. | | M CODE | | ROD SERIAL NO. | | CODE | | ROD SERIAL NO. | | COLLIMATION CHECK | | Z | | TIME | | | | | |
| 1 | | 4 | | 80 | | 1026 | | 233 | | 456511H | | 316 | | 2344567316 | | 2344568 | | EXAMPLE | | | | | | | | | |
| FROM | | | | BM DESIGNATION | | | | TO | | | | BM DESIGNATION | | | | Z | | TIME | | TEMPERATURE | | W | | S | | OB-SERVER | |
| 10-40 METHOD | | | | | | | | | | | | 113012050 | | 211 | | 22000 | | | | | | | | CWS | | | |
| SET UP | STADIA BACK | S_1 | STADIA FORE | S_2 | LOW SCALE BACK/FORE | Δh_1 | Δh_2 | HIGH SCALE BACK/FORE | Δh_{HM} | Δh_{-} | REMARKS | | | | | | | | | | | | | | | | |
| 1 | 301 | 102 | 306 | 400 | B 301:37 | - | 4.67 | B 893:75 | - | 25:31 | - | 26 | - 0.710 hcm $\Delta h_1 - \Delta h_2$ | | | | | | | | | | | | | | |
| | 290.8 | | 266.0 | | F 306:04 | | | F 919:06 | | | | | - 59.6 m $\Delta s_1 + \Delta s_2$ | | | | | | | | | | | | | | |
| | | | | | | | | | | | | $d = +21$ | | $C = +0.012$ hcm/m | | | | | | | | | | | | | |
| 2 | 302 | 100 | 298 | 398 | B 302:59 | + | 4.43 | B 916:21 | + | 25:08 | + | 35 | - 0.235 hcm | | | | | | | | | | | | | | |
| | 292.0 | 202 | 258.2 | 798 | F 298:16 | - | 0.24 | F 819:13 | - | 0:23 | - | 01 | - 1.175 mm $\Delta h_1 + \Delta h_2$ | | | | | | | | | | | | | | |
| | | | | | | | | | | | | $\Delta s_1 + \Delta s_2 = -59.6$ | | $-21 \Delta h_1 + \Delta h_2 =$ | | | | | | | | | | | | | |
| | | | | | | | | | | | | $e = e_{10} - e_{40} = -0.2$ mm | | | | | | | | | | | | | | | |
| | | | | | | | | | | | | $C = +0.013$ mm/m | | | | | | | | | | | | | | | |

Figure 3-48.—Collimation check, 10-40 method, micrometer procedure, half-centimeter rods, reversible compensator.

| NOAA FORM 76-191 18-771 | | | | | | | | | | U.S. DEPARTMENT OF COMMERCE NATIONAL OCEANIC AND ATMOSPHERIC ADMINISTRATION | | | | | | | | | | PAGE 1 of 1 | | | | | | | |
|--|-------------|-------|-------------|----------------|---------------------|--------------|--------------|-----------------------|-----------------|--|---------|--|--|---------------------------------|--|----------------|--|-------------------|--|----------------|--|------|--|-----|--|-----------|--|
| GEODETTIC LEVELING MICROMETER OBSERVATIONS (Δh) | | | | | | | | | | | | | | | | | | | | | | | | | | | |
| A | | D | | YR. NO. DAY | | CODE | | INSTRUMENT SERIAL NO. | | M CODE | | ROD SERIAL NO. | | CODE | | ROD SERIAL NO. | | COLLIMATION CHECK | | Z | | TIME | | | | | |
| 1 | | 4 | | 80 | | 11026 | | 2311 | | 506954H | | 316 | | 123456316 | | 123468 | | EXAMPLE | | | | | | | | | |
| FROM | | | | BM DESIGNATION | | | | TO | | | | BM DESIGNATION | | | | Z | | TIME | | TEMPERATURE | | W | | S | | OB-SERVER | |
| 10-40 METHOD | | | | | | | | | | | | S 114112150 | | 1185 | | 118801 | | | | | | | | CWS | | | |
| SET UP | STADIA BACK | S_1 | STADIA FORE | S_2 | LOW SCALE BACK/FORE | Δh_1 | Δh_2 | HIGH SCALE BACK/FORE | Δh_{HM} | Δh_{-} | REMARKS | | | | | | | | | | | | | | | | |
| 1 | 150 | 49 | 152 | 198 | B 150:67 | - | 2.28 | B 447:42 | - | 12:28 | + | 10 | $\Delta h_1 = 0.000$ | | | | | | | | | | | | | | |
| | 145.1 | | 132.2 | | F 152:95 | | | F 459:70 | | | | | $+ 10$ | | | | | | | | | | | | | | |
| 2 | 159 | 31 | 156 | 200 | B 159:02 | + | 2.27 | B 475:65 | + | 12:28 | - | 01 | $\Delta h_2 = -0.005$ | | | | | | | | | | | | | | |
| | 153.9 | 100 | 136.0 | 398 | F 156:75 | - | 0.01 | F 463:37 | - | 0:00 | | | $\Delta h_1 + \Delta h_2 = -0.005$ hcm | | | | | | | | | | | | | | |
| | | | | | | | | | | | | $\Delta s_1 + \Delta s_2 = -29.8 \times 2 = -59.6$ m | | $-10 \Delta h_1 + \Delta h_2 =$ | | | | | | | | | | | | | |
| | | | | | | | | | | | | $e = e_{10} - e_{40} = -0.2$ mm | | | | | | | | | | | | | | | |
| | | | | | | | | | | | | $C = -0.006$ mm/m | | | | | | | | | | | | | | | |

Figure 3-49.—Collimation check, 10-40 method, micrometer procedure, centimeter rods, nonreversible compensator.

Systematic change in the collimation error, resulting from consistent variation in the response of the compensator to gravity, is limited by strictly following the micrometer leveling procedure. The instrument is leveled while pointing in one direction, and then releveled while pointing in the opposite direction. The releveled is omitted if the compensator can be mechanically repositioned, as is the case with an instrument having a reversible compensator.

However, a compensator may "hang" or "stick" in such a way that releveled or repositioning may not remove all of the compensation error that is introduced (fig. 3-5). With a nonreversible compensator, the observer should lightly tap the side of the instrument or tripod leg during each pointing to make sure that the image oscillates. This indicates that the compensator is freely suspended. In addition, a compensation check should be performed weekly.

With a reversible compensator, whenever the compensator is repositioned the observer should check that the image oscillates. Compensation error in such an instrument results in a lack of symmetry in the two

lines of sight. The error is revealed if the mean collimation factor exceeds the tolerance during the collimation check; therefore, a separate compensation check is not necessary.

Instructions. The form commonly used for this test is NOAA Form 77-81, "Geodetic Leveling Compensation Check." The form is designed for use with the Nil leveling instrument and half-centimeter rods. An example is given in figure 3-51. The following instructions apply to any compensator instrument with a micrometer, used with double-scale rods. If a computer program is not used, prepare a standard recording form as illustrated in figures 3-52 and 3-53.

1. Make sure that the circular levels on the instrument and the rods are properly adjusted before beginning this test. (See sec. 3.3.5, "Circular-level adjustment" and 3.4.3, "Checking the circular level.")
2. Set up a leveling rod 40 m from the instrument. For convenience, use rod 2 from the last setup of the collimation check.
3. Point the instrument at the rod. Bring the bubble in the circular level to position "a," where the left

| | | | | | | | | | | | | | | | | | | | | | | | | | |
|---|---------|--------------------------------|-------------|------|--------------------------------------|-----------------------|----------------|----------------|--|---|-------|-------|----------------|-------------------|---|------------------------------|---|-----|---|--------------------|--|---|---|--|--|
| NOAA FORM 76-189 (4-77) | | | | | | | | | | U. S. DEPARTMENT OF COMMERCE NATIONAL OCEANIC AND ATMOSPHERIC ADMINISTRATION | | | | | | | | | | PAGE 1 OF 1 | | | | | |
| GEODETTIC LEVELING THREE-WIRE OBSERVATIONS | | | | | | | | | | | | | | | | | | | | | | | | | |
| * 4 0 * | | YR. / MO. / DAY | | CODE | | INSTRUMENT SERIAL NO. | | CODE | | ROD SERIAL NO. | | CODE | | ROD SERIAL NO. | | COLLIMATION CHECK EXAMPLE | | Z | | TIME | | | | | |
| * 4 1 * | | 8 0 1 0 2 6 2 3 2 | | | | 2 0 8 6 1 | | 3 1 2 | | 1 1 2 3 0 1 | | 3 1 2 | | 1 1 2 3 0 3 | | | | | | | | | | | |
| FROM | | BM DESIGNATION 10-40 METHOD | | | | TO | | BM DESIGNATION | | | | Z | | TIME BEGIN END | | TEMPERATURE BEGIN END | | W S | | OH-SERVER CWS | | | | | |
| BACKSIGHT | | | | | | | | | | FORESIGHT | | | | | | | | | | COMMENTS | | | | | |
| SET UP | UPPER | | MEAN | | BACK CENTER | | S _U | S _B | | S _L | (U+L) | | S _F | (U+L) | Σ | Σ | Σ | Σ | Σ | | | Σ | Σ | | |
| | MIDDLE | | | | | | | | | | | | | | | | | | | | | | | | |
| | LOWER | | | | | | | | | | | | | | | | | | | | | | | | |
| | Σ | | Σ | | | | | Σ | | | Σ | | | Σ | | | | | | | | | | | |
| | 1 5 8 6 | | | | | | | | | | | | | | | | | | | | | | | | |
| 1 | 1 5 3 6 | | 1 5 3 6 3 | | | | 5 0 | | | | | | | | | | | | | | | | | | |
| | 1 4 8 7 | | | | | | 4 9 | 9 9 | | | | | | | | | | | | | | | | | |
| | 1 6 2 4 | | | | | | | | | | | | | | | | | | | | | | | | |
| 2 | 1 5 7 5 | | 1 5 7 4 7 | | | | 4 9 | | | | | | | | | | | | | | | | | | |
| | 1 5 2 5 | | | | | | 5 0 | 9 9 | | | | | | | | | | | | | | | | | |
| | | | 3 1 1 1 0 | | | | | 1 9 8 | | | | | | | | | | | | | | | | | |
| | | | - 3 1 1 3 3 | | | | | - 7 9 9 | | | | | | | | | | | | | | | | | |
| | | | - 0 2 3 | | CM | | | - 6 0 1 | | m | | | | | | | | | | | | | | | |
| | | | X 1 0 | | MM/CM | | | | | | | | | | | | | | | | | | | | |
| | | | - 2 3 0 | | MM Δh ₁ + Δh ₂ | | | | | | | | | | | | | | | | | | | | |
| | | | - 0 4 0 | | MM 2 X e | | | | | | | | | | | | | | | | | | | | |
| | | | - 1 9 0 | | + | | | | | | | | | | | | | | | | | | | | |
| | | | ± - 6 0 1 | | m ΔS ₁ + ΔS ₂ | | | | | | | | | | | | | | | | | | | | |
| | | | C = + 0 0 3 | | MM/M | | | | | | | | | | | | | | | | | | | | |

Figure 3-50.—Collimation check, 10-40 method, three-wire procedure, centimeter rods.

| NOAA FORM 77-81 (2-78) | | | | U. S. DEPARTMENT OF COMMERCE NATIONAL OCEANIC AND ATMOSPHERIC ADMINISTRATION | | | | LEVEL ROD  | |
|---|-------------|------------------|-------------------|---|--|--------------------------|-------------------|--|--|
| GEODETIC LEVELING COMPENSATION CHECK <i>EXAMPLE</i> | | | | | | | | | |
| INSTRUMENT: Zeiss Ni 1/20816 | | | | | | Rod SERIAL NUMBER 123468 | | | |
| WIND | SUN | % | TIME | DATE | | | | | |
| 0 | 2 | | 0950 | 80/10/29 | | | | | |
| If $\tan \alpha$ or $\tan \beta < 0.0000097$ the compensator is in good adjustment. | | | | | | | | | |
| POSITION OF BUBBLE | HALF STADIA | ROD LEFT HALF cm | ROD RIGHT HALF cm | HALF STADIA INTERCEPT (HSI) | POSITION OF BUBBLE | ROD LEFT HALF cm | ROD RIGHT HALF cm | | |
| a | | 288 | 881 | 43.4 | c | 288 | 881 | | |
| | | 2446 | 212 | 305 | | | 750 | 305 | |
| | a | 288 | 881 | 237 | | c | 769 | 282 | |
| | c | 288 | 881 | 224 | | d | 288 | 294 | |
| | a-c | -0.049 | -0.070 | | | | | | |
| Mean (a-c) $\text{cm} = \frac{(a-c)_{\text{left}} + (a-c)_{\text{right}}}{4} = -0.030 \text{ cm}$ | | | | | REMARKS (OBSERVER/RECORDER) | | | | |
| $S_{\text{cm}} = \text{HSI} \times \text{Stadia Constant} = 4340 \text{ cm}$ | | | | | | | | | |
| $\tan \alpha = \frac{a-c}{S_{\text{cm}}} = \frac{-0.030}{4340} = -0.000069$ | | | | | | | | | |
| b | | 288 | 881 | 43.3 | d | 288 | 881 | | |
| | | 2447 | 455 | 007 | | | 497 | 007 | |
| | b | 288 | 881 | 436 | | d | 470 | 000 | |
| | d | 288 | 881 | 446 | | b | 484 | 004 | |
| | b-d | +0.446 | +0.442 | | | | | | |
| Mean (b-d) $\text{cm} = \frac{(b-d)_{\text{left}} + (b-d)_{\text{right}}}{4} = +0.2220$ | | | | | REMARKS (OBSERVER/RECORDER) <i>Instrument must be adjusted.</i> | | | | |
| $S_{\text{cm}} = 4330$ | | | | | | | | | |
| $\tan \beta = \frac{b-d}{S_{\text{cm}}} = \frac{+0.2220}{4330} = +0.0000513$ | | | | | | | | | |

Figure 3-51.—Compensation check for the Ni1 and half-centimeter rods.

edge of the bubble is just under the black line of the left edge of the circle.

4. Read the low scale of the rod. Estimate to one-thousandth of a rod unit (the third decimal place) on this and all subsequent scale readings during the test. Record the reading in column C. Record the integer portion in column A.

5. Read a stadia intercept. Record it in column A and compute the half stadia interval, HSI, in column B.

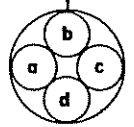
6. Read the high scale of the rod twice (two pointings). Record the readings in column E. Compute the mean in column F.

7. Read the low scale again, record the reading in column C, and compute the mean of the two low scale readings in column D.

8. Bring the bubble in the spherical level to position "c," where the right edge of the bubble is just under the black line of the right edge of the circle. Repeat the rod readings in the same order (steps 4, 6, and 7), omitting stadia readings.

9. Convert rod units to millimeters. Compute the sighting distance, s , in meters. Compute $\tan \alpha$ in millimeters per meter by the formula

$$\tan \alpha = [(a-c)_L + (a-c)_H] / 2s.$$

$\tan \alpha$ is the maximum change that may be introduced into the collimation error when the compensator is

suspended within the maximum left-right range of arc permitted by the circular level.

10. $\tan \beta$ is observed and computed in the same way. Substitute bubble position "b" for "a" and bubble position "d" for "c," and follow steps 3 through 9. $\tan \beta$ is an expression for the maximum change that may be introduced into the collimation error when the compensator is suspended within the maximum forward-backward range of arc permitted by the circular level.

11. Both $\tan \alpha$ and $\tan \beta$ must be less than ± 0.0097 mm/m (± 0.0000097). If this is not the case, the instrument should be adjusted at the repair shop or factory.

12. Submit data from the compensation check to the project office along with the leveling data acquired that day.

3.4 Leveling Rods

Leveling rods must be carefully designed, precisely manufactured, regularly calibrated, and properly used if they are to provide accurate heights above turning points and control points. In the following pages leveling rods are described, and the requirements for their use, calibration, and maintenance are presented.

3.4.1 Description

Leveling rods have often been made of seasoned hardwood, with a scale printed or stamped directly on the wood. Typically, such a rod is constructed of two or

more telescoping sections. The overall length of the scale on a wooden rod changes significantly with normal variations in atmospheric humidity. Furthermore, when assembling two or more telescoping sections, mismatches at the junctions introduce further errors in the scale. Therefore, for geodetic leveling, a much more precise rod is required. The elements essential to such a rod are described next.

Scale. The scale should be a continuous (not collapsible or folding) metal strip with a small coefficient of thermal expansion. Steel-nickel alloy (Invar) is a suitable, commonly used metal for this purpose. A scale length of 3 m (10 ft) is efficient when the height of the line of sight is expected to average from 1.5 to 2.0 m (4.9-6.6 ft). A 3.5 m (11.5 ft) rod may be preferable if the line of sight averages 2.0 to 2.5 m (6.6-8.2 ft), as in the case when observations are made from a vehicle in motorized leveling. The length of the scale sets an upper limit on the amount of scale-related error that may be accumulated in a setup.

Graduations must be accurately marked on the scale during its manufacture, and the scale must be calibrated regularly thereafter. The intervals indicated by the graduations, termed rod units, should be no larger than 1 cm (0.03 ft). Half-centimeter or centimeter units are preferred for geodetic leveling, although "centifeet" (0.01 ft) and "centiyards" (0.01 yd) have been used. The units must be compatible with the units of the micrometer in the leveling instrument. (See sec. 3.3.4, "Optical micrometer.")

The scale or its housing is usually labeled with numbers corresponding to tens of rod units. To obtain a reading, the observer must count the rod units between the point where the line of sight intercepts the scale and the first labeled number below that point. The reading is the sum of the labeled number and the number of rod units counted. To prevent blunders as a result of miscounting, every graduation could be labeled. This is possible with centimeter rods, but not with half-centimeter rods since the numbers are too small to be read at the usual sighting distances. The orientation of the labeled numbers must be compatible with the instrument, depending on whether the image provided by the instrument is upright or inverted. An inverted scale, for use with an inverting instrument, is pictured in fig. 3-54).

The type of scale must be compatible with the leveling procedure. For micrometer leveling, two parallel scales with line graduations are necessary on each rod. Line graduations are lines of finite height (0.8 to 1.6 mm), the centerlines of which define their actual positions on the scale. When intercepted with the wedge reticle (sec. 3.3.5, "Circular level adjustment"), precise readings can be made without estimation. The parallel scales are marked on the same metal strip, one offset slightly from the other, so a constant relationship exists between them even though the overall length of the scale may change. The graduations are labeled so the base of the low scale is zero, and the corresponding point on the

the high scale is about 300 cm (600 hcm). The resulting offset, in rod units, is termed the rod constant. (See fig. 3-55.)

The pair of double-scale rods must be unmatched; each rod must have a different rod constant. This permits a check to detect observations that are transposed during a setup. The rod with the smaller constant is always labeled rod 1. It should be marked with a piece of flagging or reflective tape so it can be easily recognized.

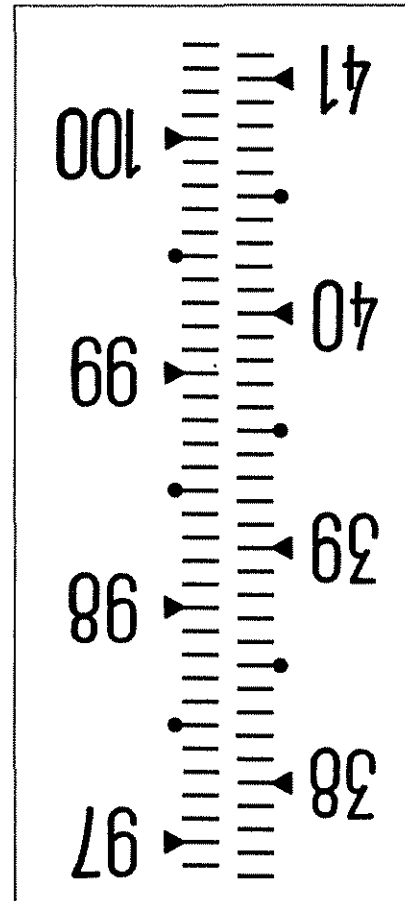

Figure 3-54.—Inverted scale for a leveling rod.

Because the scales are independent of the rod housing on which the graduation values are labeled, the rod constant may be changed if necessary. If this is done, a record must be included in the observation data specifying the date of change and the new constant. For example, if both rods of a pair have identical rod constants of 592.50, one constant can be changed to 602.50 by affixing a metal strip over the high-scale graduation values marked on the housing. The strip should be engraved with values increased by one ("60" becomes "61," etc.), to obtain the desired 10 unit change in the constant.

For three-wire leveling, rods must have single scales and block graduations. In addition, each rod should have a check scale in different units on the back. Block graduations are the borders between rectangular spaces, which usually alternate black and white in color. Each block is of a height equal to one rod unit. This type of

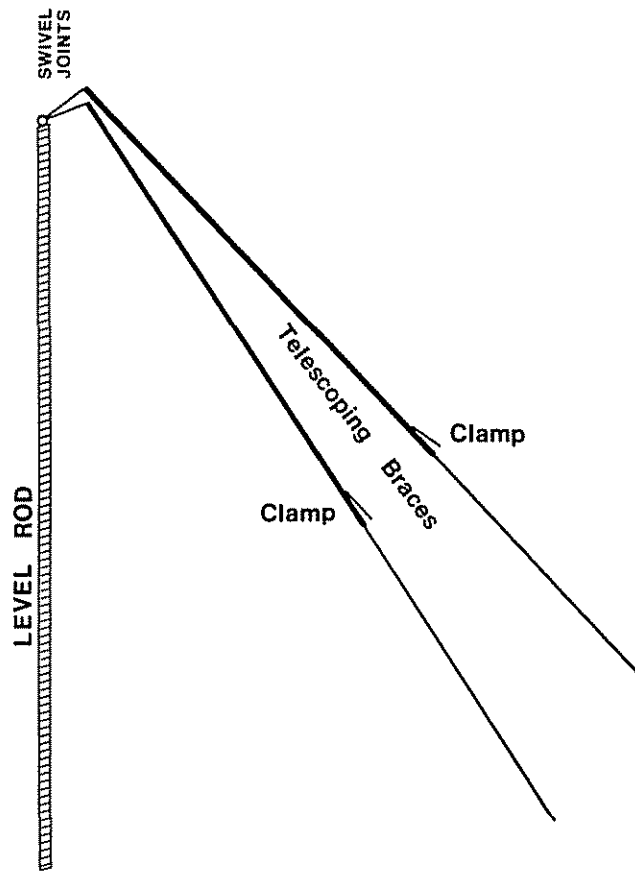

Figure 3-57.—Brace poles for a leveling rod.

3.4.2 Calibration

The rods used for geodetic leveling must be calibrated routinely by a reputable laboratory against a standard that has been compared to the National Standard of Length. A complete set of calibration data should be obtained for each rod before the rod is first used, every 5 years during its use, and just before the rod or scale is retired. The data should include the index error, length excess, and coefficient of thermal expansion. In addition, during each year of use, at least one calibration should be made to determine the index error and length excess. If a rod is dropped, or otherwise handled in a way that may have damaged it, it should not be used again until it has been recalibrated.

Each calibration consists of the precise measurement of at least four overlapping intervals on the scale (usually between the base plate and the bisected graduations at 0.2, 1.0, 2.0, and 3.0 m). The measurements, with respect to the National Standard of Length, should be accurate to ± 0.05 mm.

From one calibration a value for the index error and a factor for the length excess can be computed. The differences between the calibrated and assigned lengths of the graduations are plotted versus the assigned lengths

(fig. 3-58). The intercept of the plotted line with the axis of the differences is the index correction which is equal and opposite in sign to the index error. The slope of the line is the length excess.

To obtain a complete set of calibration data, at least four calibrations must be made, each at a different temperature between 15° and 35°C . The variations in graduation values due to changes in temperature are described by the coefficient of thermal expansion, computed from these data. To verify the amount of scale offset, at least one additional calibration of the high scale of a double-scale rod is required.

Calibration with a laser interferometer. A very accurate method for calibrating the rod scale is employed by the National Bureau of Standards, using a laser interferometer. All leveling rods used by the National Geodetic Survey should be calibrated by this method at least once during each year of use. Instead of values for four intervals, a calibrated value is obtained for every graduation on the scale. With this information, observed heights may be converted directly to “calibrated” heights.

Submitting calibration data. The complete set of calibration data must accompany any leveling data submitted to the National Geodetic Survey for inclusion in the national network. Formats for the NGS “Leveling Instrument and Rod File” are presented in *Input Formats and Specifications of the National Geodetic Survey Data Base* (Pfeifer and Morrison 1980: vol. II, ch. 6).

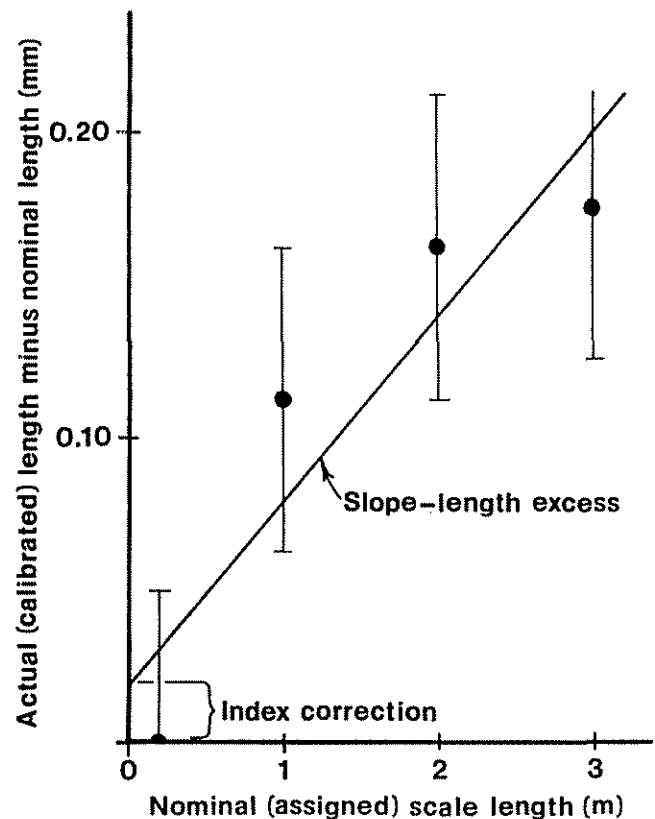

Figure 3-58.—Rod calibration data.

Calibration data should include the actual measurements and the temperatures at which they were made for each rod used. All data should be identified by the serial number of the rod. If a rod housing is reused with a new scale, the rod should be assigned a new serial number and recalibrated. The same applies if a scale is reused in a new rod housing.

3.4.3 Use and Maintenance

The leveling rod, like the leveling instrument, must be properly maintained if good quality data are to be collected. The rodman should guard the rod against physical damage and protect it from the effects of exposure to the outdoor environment. The guidelines and adjustment procedures given in this section should be strictly followed.

General handling. Because of its length, the leveling rod is so easily struck against objects that great care must be exercised when handling it. Paint does not stick easily to the special materials used for rod scales. As a result, striking the rod against any hard object (such as poles, trees, signs, rocks, vehicles, or the ground) may chip paint off the scale, making it difficult to continue observing precisely and efficiently. Such shocks may also damage the inner spring assembly or the housing, causing unpredictable change in the length of the scale.

Carry the rod by holding it with one hand at the middle and balancing it face up across your shoulder (fig. 3-59). Do not touch the painted scale. Use your arm as a spring to absorb shocks. When riding on the rear step of a truck, hold the rod parallel to the side of the truck, taking care that it does not hit the truck or any obstacles along the leveling route.

During a halt in the leveling operation, hold the rod vertically on the toe of your boot. Otherwise, place the rod in a protected location where it can be easily seen. Do not place it near the path of a vehicle. Lay it gently on the ground, with the scale facing up and the circular level protected from stress. See that no dirt or rocks are kicked on the rod while it is on the ground.

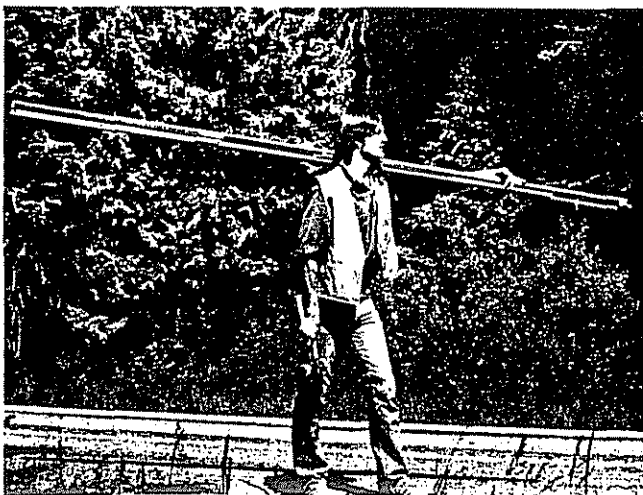

Figure 3-59.—Carrying the leveling rod.

At the end of work each day, gently wipe the rod to remove moisture and dirt. Store it, supported firmly by padding, in a box large enough to accommodate a pair of rods with brace poles and turning point guides attached. Protect the circular levels and any attached mirrors with padding or the rod handles (which may fold over the attachments).

Setting up the rod. Since the base plate corresponds to the zero point of the scale, it must be kept perfectly clean and free from corrosion if precise heights are to be observed. Before setting the rod on a point, carefully wipe away any dust or dirt on the base plate and the point. Do not allow the base plate to rest directly on the ground, since scratches may result. A rod with a defective or damaged base plate should be repaired and calibrated.

Set the rod gently onto the point; never drop it. Dropping a rod on a turning point or control point is comparable to hitting the point with a 7-kg sledgehammer. Even the best quality bench mark may suffer from such treatment.

Place the rod so that the exact center of the base plate rests on the highest point of the turning point or control marker. (See fig. 3-76 for the locations of control points on various types of monuments.) The National Geodetic Survey uses a turning-point guide (“flipper”), attached to the bottom of the rod, to assist with this centering (fig. 3-60). The guide is designed to fit around the standard turning point. If the rod is set against a flatter, broad surface, such as a bench mark disk, the guide flips back out of the way, exposing the entire base plate.

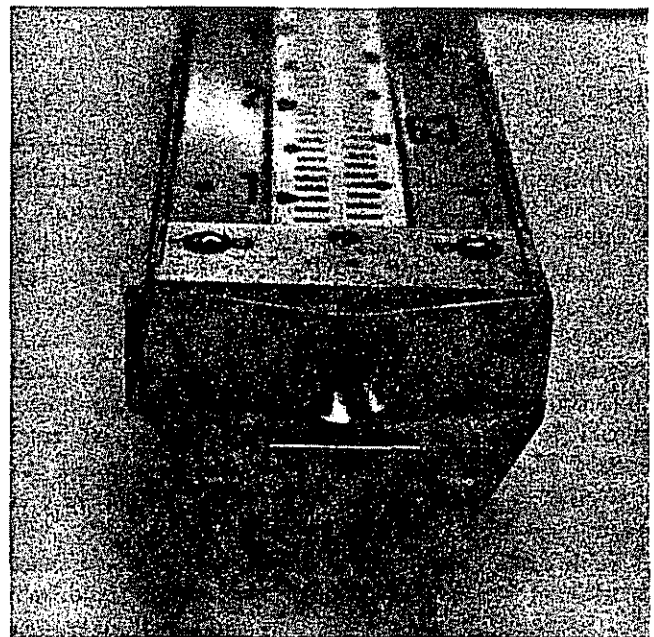

Figure 3-60.—Turning-point guide.

Be alert to the possibility that the rod can be set down in such a way that some part of the turning-point guide, instead of the base plate, is the contact point. Prevent this by turning and jiggling the rod after placing it on

the turning point. A visual examination of the point of contact may be necessary. The guide can also “hang up” inside the protective 4- or 5-inch pipe which encircles many bench marks. When setting the rod on a mark of this type, remove the turning-point guide by loosening the two finger screws.

Always place the brace poles downwind from the rod, and arrange them so they do not interfere with the observer's line of sight. Face the rod toward the instrument and plumb it by adjusting the lengths of the poles until the bubble in the circular level is centered precisely. After completing one setup, without moving the poles, rotate the rod to face the instrument at the next setup. Do not remove the rod from the turning point at any time during this cycle of two setups. If necessary, replumb it by adjusting the poles again.

Lightly hold both poles throughout each setup. Stand where the circular level can be seen to ensure that the rod is plumb, and always be ready to prevent the rod from falling (fig. 3-61). Do not press down on the poles or lean against them, since this can cause movement of the turning point.

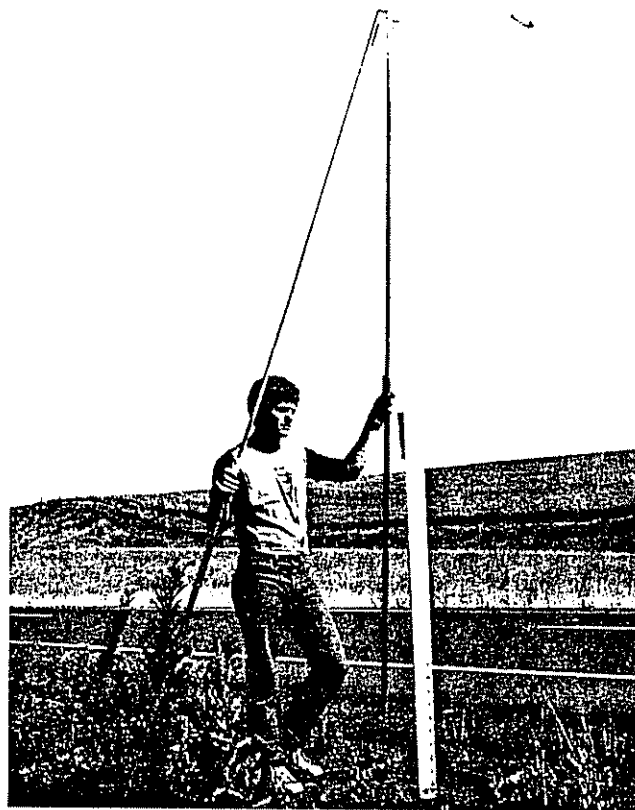

Figure 3-61.—Setup of leveling rod.

The top assembly of the brace poles must withstand a great deal of stress during leveling. Examine it regularly for loose, bent, or broken parts. The large screw, which secures the assembly to the top of the rod, may loosen and its shaft may bend if it is subjected to strain. Prevent this by checking at least once a day to see that

the screw is tight. Do not twist the poles, since this may bend the fittings which connect the poles to the top assembly. The grips lock the poles at the desired length by means of friction. They may become smooth with use and should occasionally be taken apart and roughened with sandpaper.

Checking rod plumb. During a setup each leveling rod must be plumb, in other words, vertically aligned with the direction of gravity. Achieve this by centering the bubble in the vial of the circular level attached to the rod housing. To center the bubble precisely, use a mirror or reflecting prism mounted on the rod to observe the level from as nearly overhead as possible, not from the side.

Each day, while leveling, the observer should check the plumbing of each rod by comparing the alignment of each rod to the vertical line in the reticle of the leveling instrument. Check the rod while it faces the instrument; then, after the rodman turns the rod 90° (at a right angle to the instrument), check it again. This procedure quickly reveals gross errors in the plumbing of the rod.

If the circular level is not properly adjusted, centering the bubble does not ensure that the rod is plumb. Check the level by one of the following methods at least once a week and immediately after any shock to the rod. Include a note in each weekly report, stating the time and date that the check was performed, and explaining the adjustments required.

If the level cannot be adjusted within tolerance, the rod housing may be warped or the level may be defective. In this case, check the housing by stretching a string from one end of the rod to the other and looking for bends or twists. If the rod has such defects, replace it immediately. If not, replace the circular level.

Checking the circular level. The simplest method for checking the adjustment of the circular level is the brace-pole method. To use this method, the rod must be equipped with a turning-point guide and the brace poles must be in good condition. In particular, the shaft of the large screw which centers and secures the poles to the top of the rod must be straight. If this is not the case, three guy wires, attached to the top center of the rod, may be used in lieu of the brace poles.

Set the rod on a turning point and precisely center the bubble by adjusting the length of each pole or guy wire. Lock the poles and slowly rotate the rod 360°. The bubble should not move more than 2 mm (0.08 in) from the center, a distance which represents an angular deviation from vertical of 10'0 or less. If the bubble moves more than this distance, adjust it in the same way as the one on the leveling instrument. Follow the instructions in section 3.3.5, “Circular-level adjustment,” and adjust the poles or guy wires as though they were the tribrach foot screws of the instrument.

Another method for checking the circular level is the suspension method. Begin this method by suspending the rod from an eave or other similar structure with a short piece of strong line fixed at the top center of the

rod. Anchor a piece of paper under the rod. (The back of the weekly report form is suitable.) The check and adjustment follow:

1. Plumb the rod, with the base plate resting against the paper. Trace around the front and sides of the base plate.
2. Without moving the paper, rotate the rod to face the opposite direction. Plumb it again and retrace the front and sides of the base plate. The two tracings should be parallel. If not, the rod has not been rotated completely.
3. Measure the distance between the corners of the tracings (fig. 3-62). For a 3-meter rod, if the distance is more than 2 cm (0.8 in), the circular level should be adjusted.

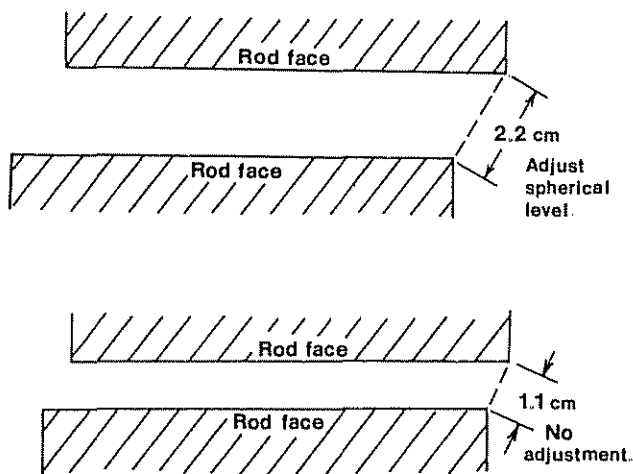

Figure 3-62.—Tracings for checking the adjustment of the circular level.

4. Before adjusting the level, move the base plate of the rod halfway back toward the first tracing and hold it there.
5. Center the bubble in the level by adjusting the small screws supporting the vial with an adjusting pin. Always turn the screws downward, to maintain pressure on the base washer. Do not retract one screw and depress another. If more adjustment play is needed, retract all the screws and begin adjusting them downward again. Do not force the vial tight against its base.
6. Turn the rod back to the original direction and perform the test again.
7. Submit the tracings and measurements to the project office with the day's leveling data or with the weekly report.

3.5 Turning Points

A turning point is the temporary support on which a leveling rod is placed during a setup. The foresight point for one setup becomes the backsight point for the next, "holding" the elevation while the leveling instrument

is moved between setups. Therefore, turning points must be stable, well defined, and properly spaced to measure accurately elevation differences from one setup to the next. The degree of care taken by the pacer and rodmen in setting and using turning points greatly affects the quality of the leveling. This is especially true in single-run leveling, since movement of the turning points between setups is not easily detected.

3.5.1 Selection and Use

A turning point should not settle or rebound. It should have a definite high point on which to hold the rod and should be easy to set and remove. Do not use objects such as stones, fire hydrants, railroad spikes and ties, or marks on the pavement. Instead, use a pair of standardized points, suitable for the terrain likely to be encountered. Any of the three types described in this section is acceptable. The most satisfactory of these for routine use, under a variety of conditions, is the turning pin. On concrete sidewalks and gravel, the turning plate is suitable. If the route crosses sandy or marshy ground (and the line cannot be relocated to avoid this), a wooden stake with a double-headed nail provides the most reliable turning point.

General instructions. When setting a turning point of any type, avoid loose soil, sand, or unpacked gravel. If necessary, dig away the loose layer with a shovel. Avoid frozen ground, but if it cannot be avoided, dig through the shallow frozen layer to unfrozen ground in which a turning point may be placed.

Once set, any turning point can settle, rebound, or be displaced surprisingly easily. Often these changes are not detectable. Be alert to the possibility of such movement by observing the following precautions: Do not drop the leveling rod onto the turning point. Do not remove the rod once it has been placed, since removing and replacing the rod can cause a significant change in the elevation of the point. Maintain a constant weight on the point by allowing the rod to stand free from downward pressure as much as possible. Do not walk around the point unnecessarily.

Turning pin. A turning pin and hammer for driving it are illustrated in figures 3-63 and 3-64.

To set a turning pin, place the driving cap over the high point and use a 2-kg (4 lb) hammer to drive the pin into the ground. The faces of the hammer should be made of replaceable soft plastic, to prevent damage to the driving cap. Do not hold the hammer with its head crossways when hammering, since this may damage the metal part of the head and make replacement of the faces difficult. Drive the pin straight, not at an angle, until the driving shoulder is within 5 cm (2 in) of the ground. If the pin is set at an angle, or not driven deeply enough, it is more likely to rebound or settle.

After setting the pin, remove the driving cap and carefully place the rod on the high point. After the setup has been checked, gently strike the side of the pin from

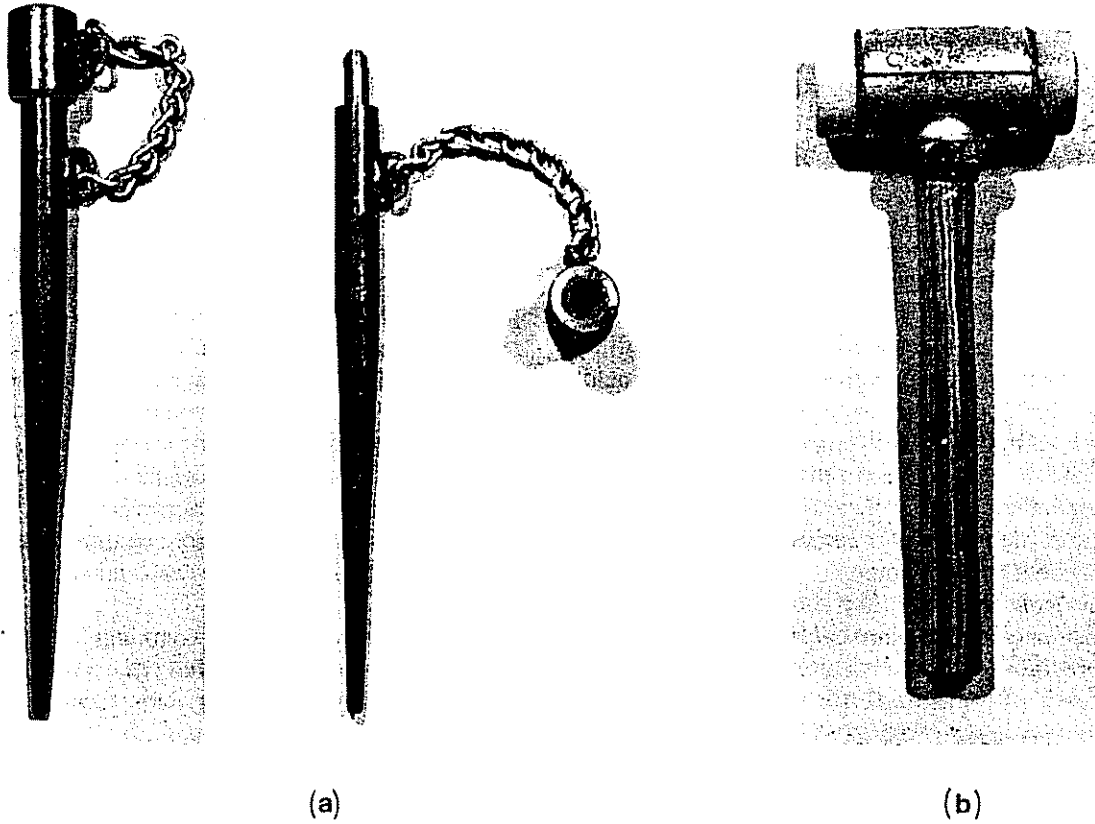

Figure 3-63.—Turning pin (a) and hammer (b).

two directions. This should loosen the pin in the ground so it can be pulled “by hand.” Avoid pulling the pin by tugging on its cap or chain.

Turning plate. When a turning pin cannot be driven efficiently, such as in the hard-packed gravel of a road shoulder, in very firm clay, or on a concrete sidewalk, use a turning plate (turtle). A turning plate should have (1) a definite high point, (2) three flat feet, and (3) weigh at least 7 kg (15 lb). Figure 3-65 shows a recommended design.

Exercise caution when setting the turning plate. Simply dropping it onto the ground will not provide enough stability. Stamp the turning plate firmly in place, even on concrete. Do not set it over small clumps of grass. Instead, use a shovel to clear a space, then tamp the plate down. When rotating the rod, maintain a constant weight on the plate, so it is not disturbed. Do not place your feet near the handle of the plate.

Wooden stake. In sandy or marshy ground or the loosely packed soil sometimes encountered on highway and railroad embankments, use a wooden stake. The stake is made from a piece of 2- by 2-inch wood cut 60-90 cm (2-3 ft) long. To use the stake as a turning point, hammer it into the ground to a firm depth, leaving about 5 cm (2 in) exposed. Then, drive a double-headed nail into the top, until the bottom head rests against the wood. The top of the nail serves as the turning point.

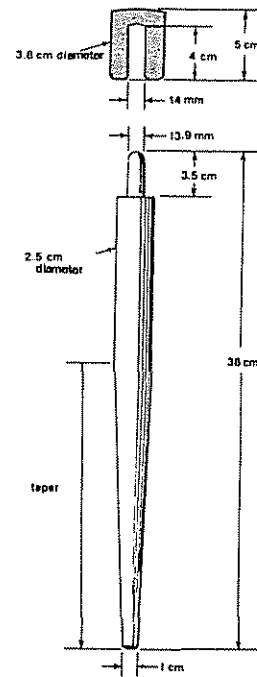

Figure 3-64.—Turning pin dimensions.

3.5.2 Pacing Balanced Setups

Many errors in leveling are reduced in magnitude by balancing setups. The distance from the leveling instrument to the foresight point must equal the distance from

the instrument to the backsight point within the tolerance for the survey. When a pacer is a member of the leveling unit, he or she should lay out a balanced setup and set the foresight point before the rodman arrives from the previous setup. This permits leveling to proceed more efficiently than when rodmen set the turning points.

To lay out a balanced setup, count paces from the backsight point to the next position for the instrument and make a mark. Then, take an equal number of paces to the spot where the foresight point is to be set.

Paces need not be of any specific length; rather, they must be consistent. A beginning pacer (or rodman) should mark a 50-meter course on level ground and pace it several times, striving to develop consistency in the number of paces taken. Most individuals take paces about a meter in length; therefore, to make a change of less than 5 m in the length of a setup, take the number of paces equivalent to the change.

Some individuals find that they routinely pace "long" (foresight distance longer than backsight distance) or "short" (foresight distance shorter than backsight distance). Learn to compensate for such tendencies, to prevent accumulating a large total of imbalances during a section of leveling. For this reason, do not move more than one setup ahead of the rest of the unit. If the observer or recorder alerts the pacer as soon as the total imbalance for the section exceeds the tolerance for one setup (see table 3-1), the pacer can reduce the total gradually instead of making one or two extremely unbalanced setups.

There are several ways to mark positions for the instrument and the turning points. If using lumber crayon ("keel"), draw a " \wedge " to show where the instrument should be placed and draw a line, circle, or "X" for the turning point. Do not use the crayon on buildings or

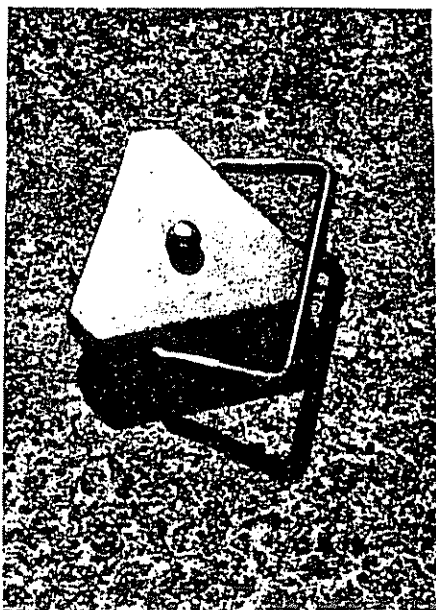

Figure 3-65.—Turning plate.

private property without explicit permission from the owner. Flagging may be useful for marking setups in brushy areas. In dirt or gravel, use a shovel or the heel of your boot to scrape a line marking the instrument setup and to clear a spot for the turning point. Do not use spray paint for marking setups. In general, the leveling unit should leave little or no evidence of its passing.

In addition to marking setups and setting turning points, use the instructions provided by the mark setting unit in the log to route the unit to the next control point. Consider both the observer's line of sight and terrain irregularities, such as slope and brush, when laying out the route. Slopes may require shorter sighting lengths than usual; a hand level is helpful when determining just how short to make them. To level to some points, it may be necessary to clear brush or hold branches away from the observer's line of sight. When an even number of setups are required between control points, the pacer must plan the final setups of a section carefully.

Four-person unit. When a leveling unit operates with four persons instead of five, the rodmen assume the tasks of pacing and setting their turning points. First, the observer paces to a position for the leveling instrument. Then the backsight rodman (from a previous setup) counts the number of paces from the last foresight point to the instrument. He or she takes the same number of paces to the next foresight point.

Specialized vehicles for motorized leveling have precise odometers with which to balance setups. Used carefully, the odometers can prevent the troublesome task of correcting a poorly paced, unbalanced setup. When advancing to the next setup, set the odometer at zero upon passing the backsight point, to count up the backsight distance. Upon passing the instrument, switch the odometer to reverse, to count down the distance to the foresight position.

When on foot or using a single truck, count regularly spaced objects such as railroad rails or highway markers to establish balanced setups.

Hand level. The hand level (fig 3-66) is a small telescope in which a spirit level is mounted in such a way that, by means of a prism, the level may be viewed at the same time that an object is viewed through the telescope. When the bubble is centered in the spirit level, a reticle line indicates the horizontal line of sight.

When leveling up or down a slope, use the hand level to select the positions for the foresight rod and the instrument at the next setup. The following instructions apply to standard, 3-meter leveling rods. (See fig. 3-67.)

1. Begin at the foresight rod of the previous setup. When leveling uphill, point and level the hand level toward the next foresight position. Select a reference object intersected by the horizontal reticle line. Proceed to the object, counting paces. (When leveling downhill, pace a conservative distance to an estimated position for the next foresight.) This procedure limits the elevation

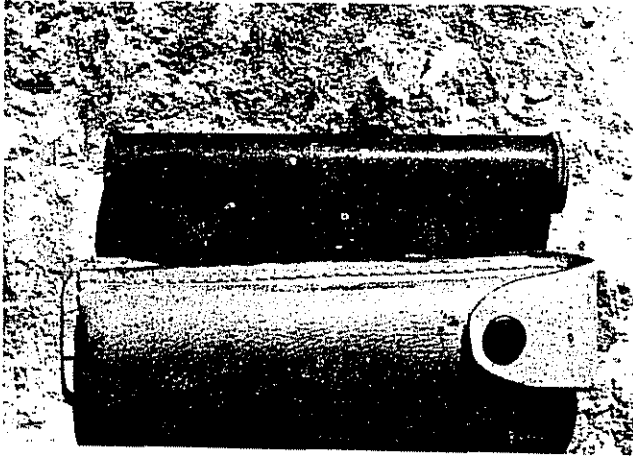

Figure 3-66.—Hand level.

difference for the setup to the height of eye of the pacer (1.6-1.8 m). With experience, the pacer can take a few extra paces to increase the elevation difference to a maximum of 2.0 m.

2. Check the foresight position by pointing and leveling the hand level toward the previous foresight rod. Looking downhill, the line of sight should pass no more than 0.5 m (1.6 ft) above the top of the rod. (Looking uphill, it should be just above the base of the rod.) Set the turning point.

3. Pace halfway back to a position for the instrument. Check it by pointing and leveling the hand level toward the previous foresight rod. Looking downhill, the line of sight should be below the top of the rod. (Looking uphill, it should be at least 0.5 m (1.6 ft) above the ground level at the rod.) Mark the position for the instrument. The pacer can omit this step and simply call out the necessary number of paces to the observer.

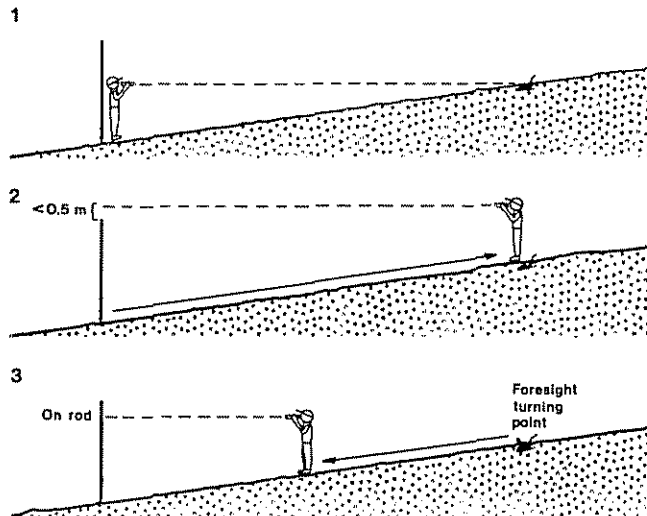

Figure 3-67.—Pacing a balanced setup on a slope.

3.6 Atmospheric Conditions

During geodetic leveling, atmospheric conditions must be determined for two purposes: to correct for the effects of atmospheric refraction on the line of sight and to correct for the effects of thermal expansion of the scales in the rods. Three measurements, recorded at the beginning and end of each section, can provide satisfactory corrections. These are air temperature, intensity of solar radiation, and wind speed. To correct more accurately for refraction, special equipment must be used to determine conditions at every setup. A method for measuring temperature differences, essential to many mathematical models of refraction, is presented here. Certain extreme atmospheric conditions may require special precautions or procedures when leveling. These are also discussed.

3.6.1 Air Temperature, Sun, and Wind

Measure the air temperature at the beginning and end of every section, as required for the observing procedure. To measure the air temperature, use a mercury thermometer with a range of at least -10° to 45°C (14° to 113°F), accurate to $\pm 0.1^{\circ}\text{C}$ ($\pm 0.2^{\circ}\text{F}$). Mount it rigidly in a shaded, protected place on the tripod (fig. 3-68). If a pair of special sensors are available for measuring temperature differences, use the top sensor. Read and record the temperature to the nearest tenth of a degree.

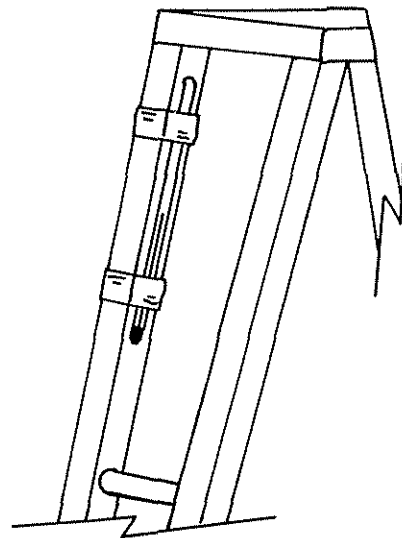

Figure 3-68.—Thermometer, mounted on tripod.

Record the intensity of solar radiation, as a single-digit sun code, at the beginning and end of every section. The sun code is defined as follows:

1. "0", if less than 25 percent of the setups are performed in sunny conditions
2. "1", if 25 percent to 75 percent of the setups are performed in sunny conditions.

3. "2", if more than 75 percent of the setups are performed in sunny conditions.

If the day is clear and sunny, but all the setups of a section are made in the shade (in other words, the entire line of sight is shaded), the code is "0". If the sky is half covered with clouds, but all the setups are made in the sun, the code is "2".

Record the wind speed, as a single-digit wind code, at the beginning and end of every section. The wind code is defined as follows:

1. "0", if wind speed averaged less than 10 km/hr (6 mi/hr).

2. "1", if wind speed averaged 10 to 25 km/hr (6 to 15 mi/hr).

3. "2", if wind speed averaged greater than 25 km/hr (15 mi/hr).

Measuring air-temperature differences. The best mathematical models for computing refraction corrections depend upon measuring at least one air-temperature difference during every setup. Temperatures are measured at two different heights above the ground. The difference is computed by subtracting the temperature at the bottom from that at the top. It is usually negative during daylight hours when the Sun heats the ground, warming the lower air layers. It is positive when the air near the ground is cooler than that above it.

Use aspirated thermometers, accurate to $\pm 0.1^{\circ}\text{C}$ ($\pm 0.2^{\circ}\text{F}$), to measure the temperature difference. A typical measuring system includes two thermistors, each shaded by a metal tube and aspirated by a small, battery-powered fan (fig. 3-69). A digital display permits readings to be made from either thermistor.

Air movement across the thermistors should be equal at all times. Check for air movement by placing your hand in front of each thermistor. A small voltmeter should indicate when batteries must be replaced to power the fans adequately. In addition, the display should indicate when its batteries must be replaced. A display battery having low voltage can cause the observed temperatures to be in error by several degrees.

Once a week, and whenever a problem is suspected, check the thermistors for consistency. Place them next to each other at the same height and pointed in the same direction. After allowing them to stabilize for 3 minutes, the temperatures should agree within $\pm 0.1^{\circ}\text{C}$ ($\pm 0.2^{\circ}\text{F}$). Note the result of this check on the recording form. If the thermistors fail to check and replacements are not available, continue leveling, but do not measure temperatures with them.

Locate the thermistors 1.3 m and 0.3 m above the ground unless specified otherwise in project instructions. These heights have been selected so the thermistors can be mounted on a tripod leg. If the tripod is used by different observers, relocate the thermistors as necessary for each observer. The thermistors must be at the correct heights above the ground when temperatures are measured.

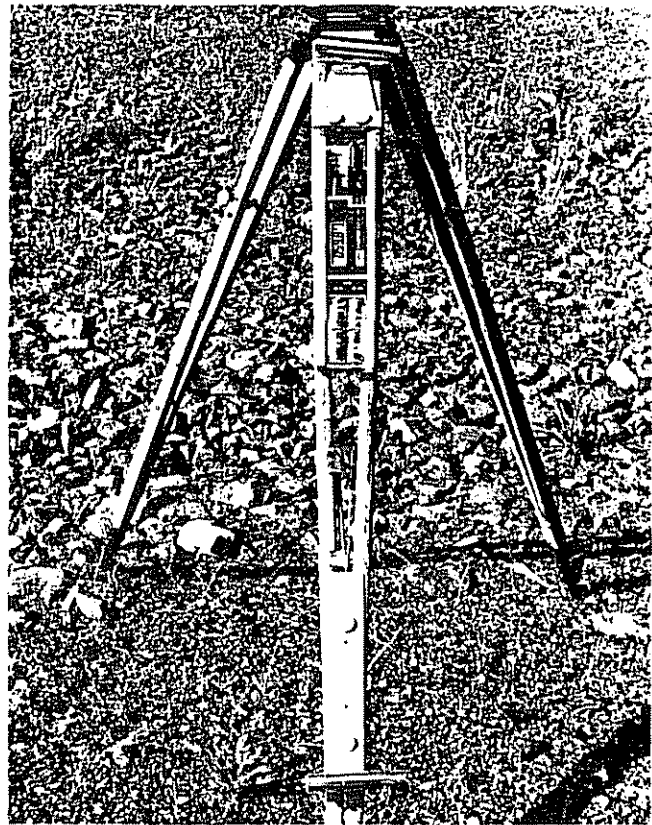

Figure 3-69.—Aspirated thermistors for measuring air-temperature differences.

Keep the thermistors inside their shields and pointed into the wind and out of sunlight at all times. Allow them to stabilize for at least 1 minute during each setup, then read the display after the leveling observations are checked. Record the temperatures to the nearest tenth of a degree, top one first. Stand away from the thermistors while reading the temperature; body heat can falsify the results.

If the tripod must be positioned temporarily in a way that lowers or raises the thermistors from the required heights, reset the tripod after the observations are complete and allow the thermistors to stabilize for 1 minute. Then, read and record the temperatures.

3.6.2 Leveling in Extreme Conditions

Do not level if the weather becomes so severe that the health or safety of personnel is threatened. Adverse weather may also affect the correct operation of equipment and result in unreliable observations. Safe working conditions are discussed in the National Geodetic Survey Operations Manual (Greenawalt and Floyd 1980).

Leveling equipment is designed to operate correctly within a broad range of temperature. However, precipitation and wind may interfere with normal operations. If precipitation is light (less than 0.5 mm/hr) continue leveling by using an umbrella to protect the instrument. Afterwards, be sure to dry each piece of equipment thoroughly before storing it. Do not level in heavy precipitation.

Wind often causes vibrations in the leveling instrument which makes observing difficult. At wind speeds in excess of 30 km/hr (19 mi/hr), leveling may be impossible. In windy conditions, use the leveling truck or an umbrella as a shield. Each rodman must be particularly attentive to maintain the rods plumb. If possible, find a less windy section of line on which to continue work until conditions improve.

Observations are not reliable if made when long-period shimmer is present. It occurs most frequently when the air is calm and the air near the ground is cooler than the air above it. It is unlikely to occur during daylight hours between 1½ hours after sunrise and ½ hour before sunset, when the air near the ground is warmer than the air above it. For this reason, restrict leveling to these daylight hours whenever possible.

Sometimes the unit must level when long-period shimmer may be present, such as in calm air over frozen ground or snow, over water, or at night. In these circumstances, double run every section.

3.7 Observing Routine

This subchapter describes the routine to be followed when leveling a line of the National Geodetic Vertical Control Network. First, general instructions are given. Second, two procedures are described: micrometer leveling and three-wire leveling. Third, precautions and special instructions are given for control points. Finally, instructions are provided for releveling and closing sections.

3.7.1 General Instructions

The leveling unit is normally assigned a line or portion of a line within a vertical control project. The line should be leveled by sections, each section beginning and ending on described, permanent control points. Each section is an unbroken series of setups, observed by a procedure that meets specifications for the order and class of survey given in the project instructions. Micrometer leveling is preferred by the National Geodetic Survey for all first- and second-order surveys. Three-wire leveling produces results of lesser precision; therefore, it is included here only as a second-order technique. The following instructions apply to either procedure.

Leveling the line. Plan the leveling route by examining the logs (instructions) prepared by the mark setters for the assigned line. Chapter 2 contains detailed requirements for routing lines of control points.

Establish the direction of leveling by giving the line a title corresponding to the intended beginning and ending points. Normally, a line begins and ends at junctions with previous or concurrent leveling. Sections leveled away from the beginning point and toward the ending point are termed forward runnings. Sections leveled in the opposite direction are termed backward runnings.

Check the project instructions and the National Geodetic Survey Operations Manual (Greenawalt and Floyd 1980) to determine the order and class of the survey, special requirements, and changes to standard procedures. Determine if the line is to be double run or single run. Review the tolerances given in table 3-1.

When a line is to be double run, level each section once forward and once backward, under different environmental conditions if possible. A good practice is to level in one direction in the morning and return in the afternoon, leveling in the other direction. Alternate the starting direction each day. The two runnings of each section must close as described in section 3.7.6, "Rejection procedure." This procedure minimizes blunders and the accumulation of most types of systematic error.

When a line is to be single run, level each section once. Alternate the direction of the runnings from one section to the next. An alternative procedure is to alternate the direction of leveling from one day to the next, maintaining an equal distance of forward and backward runnings along the line. This procedure prevents the accumulation of most types of systematic error for more than one section or day. Single-run leveling must form loops with other leveling, preferably during the same field season, to enable the detection of blunders.

Double run all spurs. A spur is a portion of line that branches off the main line of leveling, usually ending at one or more points not otherwise connected to the network. The second running provides the only check on the leveling. If a spur requires only one setup, change the height of the instrument by several centimeters between the forward and backward runnings. If the purpose of a spur is to tie a previous line of leveling, a single running is sufficient, provided it closes with the previous work.

Make single-run ties at each connection with a previous or concurrent line of leveling. Connections are normally noted in the logs. To tie to a first-order line, level to three points in the line (two sections). To tie to a second-order line, level to two points in the line (one section). To tie to an area survey, with several lines crossing the new work, level to three points from the survey that span its area.

At each connection, check the new leveling for closure with the previous, unadjusted leveling, using tolerances for whichever survey has the lower order and class. Elevation differences for the previous survey may be obtained from an unadjusted abstract for the survey. (See sec. 5.2.3, "Preliminary data.") If the sections do not close after one running, relevel them until they close to verify the new work and contact the project office immediately to find out if additional points must be leveled to complete the tie.

If the leveling of a line is interrupted for 2 weeks or more, establish a tie, as just described, before resuming work on the line. If the leveling is resumed within the same field season, a two-mark tie at least 1 km (0.6 mi)

in length is sufficient, regardless of the order and class of survey. The tie ensures that no significant movement of the control points has occurred since the leveling was interrupted.

Leveling the section The entire leveling unit must exercise the greatest possible attention to detail while leveling each section of the line. Each day check and maintain the instruments and equipment as described in this chapter. A checklist appears in table 3-4.

Explain specifically any deviation from the leveling routine. Record the following: (1) date, (2) time at which the leveling of each running began and ended, (3) personnel, and (4) equipment involved. Describe any symptoms of potential equipment failure at the time they occur.

Keep sighting distances within the prescribed tolerance for the order and class of the survey. If shimmer presents a challenge, shorten the sighting distance until acceptable readings can be made. In addition, do not allow the line of sight to pass closer than 0.5 m (1.6 ft) to the ground or to any intervening object. These precautions should reduce the error caused by refraction.

Balance the sighting distances as closely as possible on every setup, at least within the prescribed tolerance.

This reduces the effects of collimation error, refraction, and curvature.

Keep the total of the setup imbalances as small as possible, at least within the prescribed tolerance. If the accumulated imbalance becomes large during the levelings of the section, adjust the remaining setups to diminish it gradually. Do not try to correct for it with a few extremely unbalanced setups.

Complete the section as efficiently as possible, with no breaks during the series of setups. Only properly described, permanent monuments may serve as beginning and ending points. If the section cannot be completed or if a blunder occurs, reject the data collected so far. Enter on the recording form "999" for the next setup number and write a note explaining the rejection.

Except in the case of an incompleting section, do not reject any data in the field. If a blunder is found to have occurred after the fact, document it as clearly as possible on the recording form or by letter to the project office.

After completing one section, advance without a break to the first setup of the next section whenever possible. The recorder may complete the ending and beginning running records from the new setup.

Table 3-4.—Checklist for leveling

| Equipment | Check | Section reference |
|--|---------------------|-------------------|
| Leveling instrument | | |
| Tripod condition | Daily | 3.3.5 |
| Tribrach condition | Daily | 3.3.5 |
| Footscrew tension | Daily | 3.3.5 |
| Circular-level adjustment | Daily | 3.3.5 |
| Collimation check, | | |
| Nonreversible compensator | Daily | 3.3.7 |
| Reversible compensator | Weekly | 3.3.7 |
| Compensation check | Weekly | 3.3.8 |
| Clean | Weekly | 3.3.5 |
| Stadia-factor determination | As necessary | 3.3.6 |
| Leveling rods | | |
| Condition (base plate, brace poles, housing) | Daily | 3.4.1 |
| Circular-level adjustment | | |
| Check with instrument | Daily | 3.4.3 |
| Check precisely | Weekly | 3.4.3 |
| Clean | Weekly | 3.4.3 |
| Calibrate | Annually | 3.4.3 |
| Condition of turning points | Daily | 3.5.1 |
| Temperature sensors | | |
| Battery condition | Daily | 3.6.2 |
| Calibrate | Weekly | 3.6.2 |
| Computer-recording equipment | | |
| Charge batteries | Daily | 3.8.2 |
| Precondition data tapes or disks | Daily | 3.8.2 |
| Clean recording head | Weekly | 3.8.2 |
| "Cycle" batteries | Monthly | 3.8.2 |
| Clean | Monthly | 3.8.2 |
| Check programs | At start of project | 3.8.2 |
| Check all of the above whenever equipment is changed | | |

3.7.2 Micrometer Leveling

Micrometer leveling is the most precise procedure currently available for geodetic leveling. Readings are made directly from the instrument's micrometer, which provides more precise results than those provided by estimation in the three-wire leveling procedure.

The primary feature of the procedure described here is the measurement of two elevation differences during every setup. The first difference is measured from backsight to foresight, the second from foresight to backsight. Since two runnings are completed in opposite directions during every setup, each section is leveled twice, simultaneously. When this procedure is used for a single leveling of a line, it is sometimes called double-simultaneous leveling. It can be used for any order and class of survey by varying the tolerances specified in table 3-1.

To provide two different lines of sight, an instrument with a reversible compensator is preferred. An instrument without a reversible compensator can be used to provide two lines of sight if, between the two sets of observations, it is disleveled, adjusted to a slightly different height, and releveled.

To provide two different readings at each turning point, double-scale rods are used. Two rods are necessary, not only to improve efficiency, but to permit nearly simultaneous observation of the backsight and foresight. The constants of the two rods must differ, to permit a mathematical check ensuring that rods are observed in the correct order. The rod-constant difference, rod 2 minus rod 1, is labeled "d" on the recording form.

During each setup, six readings are made. First, wedge and stadia intercepts are read, backsight then foresight, from the low scale of each rod. From the two half stadia intervals the sighting distances, s_B and s_F , and the imbalance, $s_B - s_F$, are computed and checked. From the wedge intercepts the elevation difference of the low scales, Δh_L , is also computed.

Second, after changing the line of sight, wedge intercepts are read, foresight then backsight, from the high scales of each rod. From these two readings a value, $\Delta h_H \pm d$, is computed. To obtain the elevation difference of the high scales, Δh_H , the rod-constant difference, d , must be added or subtracted, depending on which rod is observed as the backsight. Then Δh_L and Δh_H are compared.

Balancing the sighting distances should reduce the effects of collimation error, moderate refraction, and curvature to immeasurable amounts during the setup. However, error in the pointings may still cause a slight difference between Δh_L and Δh_H . The difference, $\Delta h_L - \Delta h_H$, is compared to a tolerance to check for a value greater than might be expected as a result of random pointing error. This comparison is called the reading check:

$$\Delta h_L - \Delta h_H \leq \text{tolerance.}$$

To determine a suitable tolerance for the reading check, the other tolerances for the leveling procedure must be considered. If the collimation error does not change between the low- and high-scale observations, the tolerance may be derived from the standard deviation of a single pointing, which, in turn, depends on the sighting distance and the optics of the instrument. With a sufficiently powerful computer-recording system, a formula might be used to compute the tolerance appropriate to the actual sighting distances of each setup. Usually, however, a single tolerance is derived, appropriate to the maximum sighting distance permitted for the order and class of the survey. The tolerances given in table 3-1 are of this type.

If the collimation error is different for the low- and high-scale observations, as is the case with a reversible compensator, the setup imbalance affects the tolerance for the reading check. For example, the difference in the collimation errors for position one and position two of the Jenoptik N1 002 affects $\Delta h_L - \Delta h_H$ by an amount that depends on the setup imbalance and $C_1 - C_2$. Since the angular difference, $C_1 - C_2$, changes somewhat unpredictably both in magnitude and sign, the tolerance for the reading check must be derived from the maximum setup imbalance permitted for the order and class of the survey and the maximum magnitude of $C_1 - C_2$ in addition to the standard deviation of each pointing.

After satisfying the reading check, temperatures are recorded so a refraction correction can be computed and applied to the data before adjustment. Then, the two elevation differences are averaged to obtain the elevation difference for the setup:

$$\Delta h = 0.5 \times (\Delta h_L + \Delta h_H)$$

As each setup is completed, the new difference is added to the sum of the previous differences. Thus, at the end of the section, the total elevation difference between the marks is obtained. For convenience when setup data are recorded on paper, Δh_L and $\Delta h_H \pm d$ are summed separately. The elevation difference is then computed at the end of the section.

Though this leveling procedure is designed to prevent blunders and the accumulation of systematic error, both may still occur without warning. Note, for example, that there is no check for movement of the turning points between setups. As with any procedure, strict attention must be paid to the precautions and guidelines presented in the rest of this chapter.

Instructions. The following instructions apply to a properly adjusted leveling instrument with a micrometer, used with a pair of calibrated, double-scale rods. If the instrument does not have a reversible compensator, substitute the following procedure whenever instructed to change the position of the compensator: Dislevel the instrument using the footscrew closest to the foresight rod, then relevel it using the other two footscrews.

If possible, record the observations in a computer and, if required, prepare a backup recording form (NOAA Form 77-82, "Geodetic Leveling") The instructions presented here include the procedure for using NOAA Form 76-191, "Geodetic Leveling Micrometer Observations." Use a separate recording form for each running. (See figs 3-70 through 3-72 for sample records.)

2. Establish a balanced setup with the backsight rod plumbed on the beginning control point of the section, the foresight rod plumbed on a turning point, and the instrument set in line between them. Check for parallax Using the instrument, check that the rods are plumb.

3. BEGINNING RUNNING RECORD: Immediately before leveling begins, prepare the beginning running record (line *41*). Include the following items of information: The survey-point serial number of the beginning control point, the stamping on the point (or designation if no stamping exists), the local time, the air temperature, the wind code, the sun code, and the number of the rod on the control point. CAUTION: Check that the rod identified is, in fact, on the point identified. The recorded stamping must correspond to that on the mark leveled. Check and initial the survey-point serial number entered on the form.

4. BACKSIGHT, LOW SCALE: Level the instrument while pointing at the backsight rod. In compensator position one (odd-numbered setup) or two (even-numbered setup), read the wedge intercept on the low scale. Pause slightly between the three- or four-digit rod-unit reading and the two-digit micrometer reading, so the recorder can enter the decimal correctly. The recorder should call out any uncertain numbers for the observer to verify. Record the entire reading in column F, backsight. Record the rod-unit reading only in column B.

5. Read the intercept of the lower stadia line, estimating to tenths of rod units, on the low scale. Again, pause during the reading to indicate the decimal. Record it in column B. Compute the half-stadia interval by subtracting the stadia reading from the rod units of the first reading. With half-centimeter rods this value is the backsight distance, s_B . With centimeter rods, multiply the interval by 2 to compute the distance.

6. FORESIGHT, LOW SCALE: Point toward the foresight rod. Make sure the rod has rested on the point for 20 seconds or more. Still in the same compensator position, read the low scale as before. Record the readings in column F, foresight, and column D. Compute the foresight distance, s_F . Check that the imbalance, $s_B - s_F$, is within tolerance for the survey. If it is not, relocate either the foresight rod or the instrument and begin again at step 4. Compute the low-scale elevation difference, Δh_L , by subtracting the foresight from the backsight.

7. FORESIGHT, HIGH SCALE: Still pointing toward the foresight rod, change the compensator position (or dislevel and relevel the instrument). Read the high scale. Record the reading in column H, foresight.

8. BACKSIGHT, HIGH SCALE: Point toward the backsight rod, in the same compensator position, and read the high scale. Record the reading in column H, backsight. Compute $\Delta h_H \pm d$ by subtracting the foresight from the backsight

| GEODETTIC LEVELING | | | | | | | | | | | |
|---|----------------|--------------------|-------------|------------------|--------------|--|--------------|---------|-------------------------------------|--|--|
| LINE <i>L 24582 Line 364A</i> | | | | | | TAPE NO. <i>NM12</i> | | | | | |
| PROJ. NO. <i>NGVD Region 4</i> | | | | | | PAGE <i>1</i> OF <i>8</i> | | | | | |
| ST 0 | ST 1 | ST 2 | ST 3 | | | | | | | | |
| DATA | YR. | MO. | DY. | ZONE | INST. NO. | | | CODE | | | |
| * 4 0 * | 8 0 | 0 4 | 0 4 | 2 0 | 4 5 6 5 1 1 | | | . 2 3 3 | | | |
| ST 4 | | | | | | ST 5 | | | | | |
| ROD NO. 1 | | | | | | ROD NO. 2 | | | | | |
| 2 6 9 7 2 2 | | | | | | . 3 1 6 | | | | | |
| 2 7 7 9 2 6 | | | | | | . 3 1 6 | | | | | |
| ST 6 | ST 7 | ST 8 | ST 9 | | | | | | | | |
| OBSERVER | TIME | COILIM. FACTOR | ROD UNITS | | | STAD | | | C | | |
| <i>LHT</i> | <i>06 30</i> | <i>- 0 . 0 0 2</i> | <i>3 HC</i> | | | | | | <input checked="" type="checkbox"/> | | |
| D - WRITE ON TAPE - 9 | | | | | | BLOCK <i>0 1 - 0 7</i> | | | | | |
| ST 0 | ST 1 | DESIGNATION | | | | | | | | | |
| DATA | FROM: | <i>M 198 1935</i> | | | | | | | | | |
| * 4 1 * | <i>2 2 1 0</i> | | | | | | | | | | |
| ST 2 | | DESIGNATION | | | | | | | | | |
| TO: | | <i>S 260 1980</i> | | | | | | | | | |
| <i>2 2 1 2</i> | | | | | | | | | | | |
| ST 3 | ST 4 | ST 5 | ST 6 | ST 7 | BLOCK | | | | | | |
| TIME | TEMP | WIND | SUN | DATE | <i>0 1 -</i> | | | | | | |
| <i>0 6 5 3</i> | <i>- 2 0</i> | <i>0</i> | <i>1 8</i> | <i>0 0 4 0 4</i> | <i>0 8</i> | | | | | | |
| D - WRITE ON TAPE - 7 | | | | | | 5 - CLR | | | | | |
| ELEV. DIFF. | | | | | | J.S.5 | | | | | |
| <i>- 5 . 7 6 4 3 5</i> | | | | | | <i>1 - 2 8 1 2</i> | | | | | |
| ST 0 | ST 1 | ST 2 | ST 3 | ST 4 | BLOCK | | | | | | |
| DATA | TIME | TEMP | WIND | SUN | OBS. | REC. | <i>0 3 -</i> | | | | |
| * 4 1 * | <i>0 8 0 5</i> | <i>4 1</i> | <i>0</i> | <i>2</i> | <i>LHT</i> | <i>CWS</i> | <i>0 5</i> | | | | |
| D - WRITE ON TAPE - 4 | | | | | | ROD #1 <i>TJJ</i> ROD #2 <i>RMD</i> | | | | | |
| REMARKS | | | | | | REMARKS | | | | | |
| <i>Wrong SP5N on tape. "2212" should be "2211."</i> | | | | | | <i>M 198 to checkpoint:</i> <i>382.31</i> <i>- 371.02</i> <i>+ 11.29</i> <i>800403: - + 11.41</i> <i>- .12 mm</i> <i>x 5</i> <i>- 0.60 mm</i> | | | | | |

Figure 3-70.—Micrometer leveling, backup form for a computer-recording system.

1. EQUIPMENT RECORD: At the start of each day, or at any change of the observer, equipment, or collimation factor, prepare the survey-equipment record (line *40*). Include the date, the instrument code and serial number, the rod codes and serial numbers, the local time zone and time, the type of temperature units, the collimation factor at the last check, and the initials of the observer, recorder, and rodmen. CAUTION: Each work day check all serial numbers against the actual equipment used. Also, check that the record of the collimation factor is correct.

| NOAA FORM 74-191 (8-77) | | | | | | | | | | U.S. DEPARTMENT OF COMMERCE NATIONAL OCEANIC AND ATMOSPHERIC ADMINISTRATION | | | | | | | | | | PAGE | | | | | | | | | |
|--|-------------|-----|-------------|------|---------------------|-----------------------|----------------------|-----------------|-----------------|---|--|--------------------------------------|----------------|-------------|------|------------|--|-----|--|--------|--|--|--|--|--|--|--|--|--|
| GEODETIC LEVELING MICROMETER OBSERVATIONS (Δh) EXAMPLE | | | | | | | | | | First Order, Class I | | | | | | | | | | 1 of 1 | | | | | | | | | |
| 4 | 0 | YR. | NO. | DAY | CODE | INSTRUMENT SERIAL NO. | M | CODE | ROD SERIAL NO. | CODE | ROD SERIAL NO. | CODE | ROD SERIAL NO. | Z | TIME | | | | | | | | | | | | | | |
| 0 | 1 | 80 | 11 | 14 | 231 | 5802143 | 16 | | 1481972 | 316 | | 1481974 | | | | | | | | | | | | | | | | | |
| FROM | | | | | TO | | | | | Z | | TIME | | TEMPERATURE | | SUB-SERVER | | | | | | | | | | | | | |
| 1236 TOP No 2 1948 | | | | | 1237 M 306 1979 | | | | | R 1420 | | 1445 | | 172 | | 117801 | | CWS | | | | | | | | | | | |
| SET UP | STADIA BACK | M | STADIA FORE | IF | LOW SCALE BACK/FORE | Δh _L | HIGH SCALE BACK/FORE | Δh _H | Δh _M | Δh _h | REMARKS | | | | | | | | | | | | | | | | | | |
| 1 | 357 | | 514 | 55 | 530 | 35772 | 10224 | 94953 | 8127 | -03 | Reading check = ± 0.8 cm Imbalance = ± 2.0 m Section imbalance = ± 4.0 m | | | | | | | | | | | | | | | | | | |
| | 3056 | | 2820 | | 25548 | | 86826 | | | | | | | | | | | | | | | | | | | | | | |
| | | | | | | | | | | | | $\Delta S = S_B - S_F = -1.6$ | | | | | | | | | | | | | | | | | |
| | | | | | | | | | | | | $d = +2.1$ | | | | | | | | | | | | | | | | | |
| 2 | 372 | | 525 | 250 | 510 | 37280 | 12188 | 98697 | 14283 | +05 | | | | | | | | | | | | | | | | | | | |
| | 3195 | | 1039 | 190 | 1040 | 25092 | 22412 | 84414 | 22410 | +02 | | | | | | | | | | | | | | | | | | | |
| | | | | | | | | | | | | $d = +2.1$ | | | | | | | | | | | | | | | | | |
| R | 3379 | | 525 | 254 | 510 | 37936 | 12489 | 97179 | 10380 | +09 | R | | | | | | | | | | | | | | | | | | |
| | 3265 | | 2010 | | 25447 | | 86739 | | | | | | | | | | | | | | | | | | | | | | |
| | | | | | | | | | | | | $+1.5$ | | | | | | | | | | | | | | | | | |
| 3 | 379 | | 525 | 254 | 510 | 37935 | 12487 | 97120 | 10380 | +01 | | | | | | | | | | | | | | | | | | | |
| | 3265 | | 1564 | 2070 | 1550 | 25454 | 34893 | 86740 | 32790 | +03 | | | | | | | | | | | | | | | | | | | |
| | | | | | | | | | | | | $+1.5$ | | | | | | | | | | | | | | | | | |
| 4 | 358 | | 543 | 225 | 540 | 35856 | 13317 | 97273 | 14413 | +04 | | | | | | | | | | | | | | | | | | | |
| | 3037 | | 2107 | 1710 | 2090 | 22539 | 48210 | 81860 | 48203 | +07 | | | | | | | | | | | | | | | | | | | |
| | | | | | | | | | | | | $+0.3$ | | | | | | | | | | | | | | | | | |
| R | 5346 | | 545 | 261 | 511 | 34674 | | | | | R | | | | | | | | | | | | | | | | | | |
| | 2915 | | 2099 | | 26190 | | | | | | | | | | | | | | | | | | | | | | | | |
| | | | | | | | | | | | | $+3.4 > 2.0 \text{ m}$ | | | | | | | | | | | | | | | | | |
| 5 | 346 | | 545 | 261 | 550 | 34672 | 8483 | 93859 | 6385 | -02 | | | | | | | | | | | | | | | | | | | |
| | 2915 | | 2652 | 2060 | 2640 | 26189 | 56693 | 87474 | 54588 | +05 | | | | | | | | | | | | | | | | | | | |
| | | | | | | | | | | | | -0.5 | | | | | | | | | | | | | | | | | |
| 6 | 360 | | 500 | 057 | 520 | 36014 | 30253 | 97428 | 32348 | +05 | BM vertical. Used 1-meter scale. $+ 869.410 \text{ cm}$ 200 Ac/m $+ 4.34705 \text{ m}$ | | | | | | | | | | | | | | | | | | |
| | 3120 | | 3152 | 1020 | 3160 | 05767 | 86946 | 65080 | 86936 | 010 | | | | | | | | | | | | | | | | | | | |
| | | | | | | | | | | | | $+ 3160$ | | | | | | | | | | | | | | | | | |
| | | | | | | | | | | | | $-2.0 \pm \Delta S = -0.8 \text{ m}$ | | | | | | | | | | | | | | | | | |
| | | | | | | | | | | | | $\pm 1 \text{ Mean } \Delta h =$ | | | | | | | | | | | | | | | | | |
| | | | | | | | | | | | | $S = 0.63 \text{ km}$ | | | | | | | | | | | | | | | | | |

Figure 3-71.—Micrometer leveling, half-centimeter rods.

| NOAA FORM 74-191 (8-77) | | | | | | | | | | U.S. DEPARTMENT OF COMMERCE NATIONAL OCEANIC AND ATMOSPHERIC ADMINISTRATION | | | | | | | | | | PAGE | | | | | | | | | |
|--|-------------|-----|-------------|------|---------------------|-----------------------|----------------------|-----------------|-----------------|---|---|---|----------------|-------------|------|------------|--|-----|--|--------|--|--|--|--|--|--|--|--|--|
| GEODETIC LEVELING MICROMETER OBSERVATIONS (Δh) EXAMPLE | | | | | | | | | | First Order, Class II | | | | | | | | | | 1 of 1 | | | | | | | | | |
| 4 | 0 | YR. | NO. | DAY | CODE | INSTRUMENT SERIAL NO. | M | CODE | ROD SERIAL NO. | CODE | ROD SERIAL NO. | CODE | ROD SERIAL NO. | Z | TIME | | | | | | | | | | | | | | |
| 0 | 1 | 80 | 11 | 14 | 231 | 5802143 | 16 | | 1083223 | 16 | | 1083224 | | | | | | | | | | | | | | | | | |
| FROM | | | | | TO | | | | | Z | | TIME | | TEMPERATURE | | SUB-SERVER | | | | | | | | | | | | | |
| 6013 B 301 1967 | | | | | 6012 M 31 1930 | | | | | S 1302 | | 1333 | | 1153 | | 116002 | | CWS | | | | | | | | | | | |
| SET UP | STADIA BACK | M | STADIA FORE | IF | LOW SCALE BACK/FORE | Δh _L | HIGH SCALE BACK/FORE | Δh _H | Δh _M | Δh _h | REMARKS | | | | | | | | | | | | | | | | | | |
| 1 | 155 | | 240 | 164 | 241 | 15520 | 896 | 45197 | 1899 | -02 | Reading check = ± .10 cm Imbalance = ± 5.0 m Section imbalance = ± 10.0 m | | | | | | | | | | | | | | | | | | |
| | 1310 | | 1139 | 9 | 164116 | | 47085 | | | | | | | | | | | | | | | | | | | | | | |
| | | | | | | | | | | | | $\Delta S = S_B - S_F = -0.1 \times 2 = -0.2 \text{ m}$ | | | | | | | | | | | | | | | | | |
| | | | | | | | | | | | | $d = +1.0$ | | | | | | | | | | | | | | | | | |
| 2 | 148 | | 225 | 146 | 234 | 14856 | 213 | 45484 | 1210 | +03 | | | | | | | | | | | | | | | | | | | |
| | 1255 | | 465 | 1226 | 475 | 14643 | 683 | 49274 | 684 | +01 | | | | | | | | | | | | | | | | | | | |
| | | | | | | | | | | | | $-0.9 \times 2 = -1.8$ | | | | | | | | | | | | | | | | | |
| | | | | | | | | | | | | -1.0 | | | | | | | | | | | | | | | | | |
| 3 | 188 | | 240 | 178 | 230 | 18816 | 1417 | 48455 | 416 | +01 | | | | | | | | | | | | | | | | | | | |
| | 164 | | 705 | 150 | 705 | 17399 | 734 | 48039 | 268 | +02 | | | | | | | | | | | | | | | | | | | |
| | | | | | | | | | | | | $+1.0 \times 2 = 2.0$ | | | | | | | | | | | | | | | | | |
| | | | | | | | | | | | | $+1.0$ | | | | | | | | | | | | | | | | | |
| R | 164 | | 186 | 161 | 160 | 16421 | | | | | R | | | | | | | | | | | | | | | | | | |
| | 1454 | | 1450 | | 161109 | | | | | | | | | | | | | | | | | | | | | | | | |
| | | | | | | | | | | | | $+2.6 \times 2 = 5.2 > 5.0$ | | | | | | | | | | | | | | | | | |
| | | | | | | | | | | | | -1.0 | | | | | | | | | | | | | | | | | |
| 4 | 164 | | 171 | 162 | 170 | 16465 | 264 | 47115 | 1265 | -01 | | | | | | | | | | | | | | | | | | | |
| | 1469 | | 876 | 1450 | 875 | 16207 | 498 | 45850 | 997 | +01 | | | | | | | | | | | | | | | | | | | |
| | | | | | | | | | | | | $+0.1 \times 2 = 0.2$ | | | | | | | | | | | | | | | | | |
| | | | | | | | | | | | | -1.0 | | | | | | | | | | | | | | | | | |
| R | 5147 | | 225 | 157 | 225 | 14767 | 987 | 44408 | 1973 | -14 | R | | | | | | | | | | | | | | | | | | |
| | 1245 | | 1345 | | 15754 | | | 46381 | | | | | | | | | | | | | | | | | | | | | |
| | | | | | | | | | | | | 0.0 | | | | | | | | | | | | | | | | | |
| | | | | | | | | | | | | $+1.0$ | | | | | | | | | | | | | | | | | |
| 5 | 147 | | 225 | 157 | 225 | 14766 | 989 | 44398 | 1988 | -01 | | | | | | | | | | | | | | | | | | | |
| | 1245 | | 1100 | 1345 | 1100 | 15755 | 009 | 46386 | 991 | 00 | | | | | | | | | | | | | | | | | | | |
| | | | | | | | | | | | | 0.0 | | | | | | | | | | | | | | | | | |
| | | | | | | | | | | | | $+1.0$ | | | | | | | | | | | | | | | | | |
| 6 | 166 | | 234 | 143 | 230 | 16625 | 2262 | 47275 | 3263 | -01 | | | | | | | | | | | | | | | | | | | |
| | 1426 | | 1335 | 1200 | 1330 | 14363 | 2271 | 44012 | 2272 | -01 | | | | | | | | | | | | | | | | | | | |
| | | | | | | | | | | | | $+0.5 \times 2 = 1.0$ | | | | | | | | | | | | | | | | | |
| | | | | | | | | | | | | -1.0 | | | | | | | | | | | | | | | | | |
| 999 | | | | | | | | | | | Rodman Jones pulled foresight pin. | | | | | | | | | | | | | | | | | | |

Figure 3-72.—Micrometer leveling, centimeter rods.

9. **READING CHECK:** Compute $\Delta h_L - \Delta h_H$. To do this, if rod 1 is the backsight rod, add d to $\Delta h_H \pm d$. If rod 2 is the backsight rod, subtract d from $\Delta h_H \pm d$. Then subtract Δh_H from Δh_L . Compare the result to the tolerance for the survey. **CAUTION:** Do not move the backsight turning point until the reading check is complete. If the point is moved, even only slightly, the data collected so far must be rejected and the running of the section must be begun again at step 2.

10. If the readings fail to check, begin the setup again at step 4. If they repeatedly fail to check, try one or more of the following procedures:

- (1) Check for parallax and remove it if present
- (2) Check the plumb of the rods and the leveling of the instrument, including the adjustment of the circular level.
- (3) Check that the reversible compensator is correctly positioned
- (4) Reposition the instrument to balance the setup exactly.
- (5) Shorten the sighting distances by repositioning the instrument and the foresight rod.
- (6) Check that the rods are being observed in the correct order (backsight first).
- (7) Check that the rod-constant difference, d , is entered with the correct magnitude and sign.
- (8) Check that the starting rod for the section was identified correctly and that the current setup number is correct.
- (9) Make a collimation check (sec. 3.3.7).
- (10) Make a compensation check (sec. 3.3.8).
- (11) Consider the possible presence of unusual environmental conditions (sec. 3.6.3), such as long-period shimmer. Return to the section when conditions improve.

11. After obtaining a reading check, record the air temperatures for the refraction correction if the appropriate equipment is available (sec. 3.6.2). Similarly, record temperatures of the rod scales if the appropriate equipment is available. With a computer-recording system, check that the temperatures are reasonable.

12. Check the accumulated imbalance for the section. If it is more than the tolerance for one setup, alert the pacer or rodmen to adjust the next setup or setups accordingly. When recording on paper, sum the backsight and foresight distances separately; then compare the overall imbalance. Also, sum the low-scale and high-scale elevation differences separately; at the end of each even-numbered setup the differences should agree closely (though not necessarily within the tolerance for the reading check).

13. **NEXT SETUP:** Leaving the compensator in the same position, advance to the next setup. Leave the foresight rod (and turning point) in place to become the next backsight rod. Move the former backsight rod and turning point to the next foresight position. Set the instrument on a line halfway between the two rods. **CAUTION:** Do not remove the former foresight rod from its turning point. Keeping it centered on the point, pivot it to face the instrument.

14. Repeat steps 4 through 13 at the next setup. Remember that the backsight, low scale is observed first on every setup, but the rods, the compensator positions, and the sign of d alternate on every setup. (See table 3-5 for a summary of the procedure.)

15. As the unit approaches the end of the section, if required, adjust the sighting distances to make an even number of setups for the section. The final setup should have rod 1 on the control point and rod 2 on the last turning point. An even number of setups is not required if all graduations of both rods have been calibrated by laser interferometry (See sec. 3.4.2, "Calibration with a laser interferometer.")

16. **ENDING RUNNING RECORD:** After completing the last setup of the section, prepare the ending running record (line *41*). Include the following items of information: the survey-point serial number of the ending control point, the stamping on the point (or designation if no stamping exists), the local time, the air temperature, the wind code, and the sun code. Compute and record in meters the elevation difference of the section. Compute and record in kilometers the length of the section. Record the number of setups. If the leveling is the second running of a section, check for closure (sec. 3.7.7). **CAUTION:** Make sure the stamping entered for the ending point corresponds exactly to that on the mark on which the rod is resting.

Table 3-5.—Summary of the micrometer leveling procedure

| During each setup | | | |
|--------------------|---|----------------------|--|
| 1 | Balance setup. | | |
| 2 | Point instrument at backsight. | | |
| 3 | Level instrument and plumb rods | | |
| 4 | Read backsight, low scale: wedge and stadia | | |
| 5 | Point to and read foresight, low scale: wedge and stadia | | |
| 6 | Check sighting distances and imbalance against tolerances | | |
| 7 | Change compensator position or dislevel-relevel | | |
| 8 | Read foresight, high scale: wedge | | |
| 9 | Point to and read backsight, high scale: wedge | | |
| 10 | Check low- and high-scale elevation differences against tolerance | | |
| 11 | Read temperatures. | | |
| 12 | Check accumulated imbalance against tolerance | | |
| 13 | Move to next setup | | |
| During the section | | | |
| Number setup | Scale observed | Compensator position | |
| 1 | low | • | |
| | high | •• | |
| 2 | low | •• | |
| | high | • | |
| 3 | low | • | |
| | high | •• | |
| • | • | | |
| • | • | | |
| • | • | | |

3.7.3 Three-Wire Leveling

Until the advent of leveling instruments equipped with micrometers, three-wire leveling was the most precise method for measuring elevation differences. However, without a micrometer, scale readings must be estimated and only one elevation difference can be measured efficiently during each setup. The method described here can provide differences with a precision sufficient for second- or lower-order surveys.

The instrument need only provide a single, consistent line of sight during each setup. Two nearly identical rods are used to permit nearly simultaneous observation of the backsight and foresight. Only one calibrated scale is necessary on each rod; however, a second uncalibrated scale on the back of the rod should be read as a check for blunders. To estimate readings with the greatest precision, the calibrated scale is graduated with blocks, preferably in a checkerboard pattern. (See sec. 3.4.1, "Scale.")

During each setup, eight readings are made. First, the intercepts of the upper, middle, and lower reticle lines ("wires") are read from the calibrated scale of rod 1. Then, the intercept of the middle line with the back scale is read. The four readings are estimated to the nearest tenth of a rod unit.

Two checks are made. To check the internal consistency of the three precise readings, the half stadia intervals, s_U and s_L , are computed and their difference is compared to a tolerance. To detect gross blunders of decimeters or meters, the reading of the middle reticle line is compared to the back-scale reading. Since the precise readings are made nearly simultaneously, a consistent error in the first or second digit might otherwise go undetected. This is particularly likely when leveling moves from flat to sloping terrain and the readings increase abruptly by a full meter.

Second, four more intercepts are read and checked from rod 2. The sighting distances are computed by summing the half stadia intervals for each rod. Then, the imbalance is computed and checked against the tolerance.

Rod 1 is observed first during each setup. Thus, the backsights and foresights are observed in alternate order on alternate setups, to reduce systematic error. This is especially important when using a compensator instrument, to prevent the accumulation of systematic error due to consistent variation in the collimation error. (See sec. 3.3.8, "Compensation check.")

The elevation difference for each setup is the difference between the mean of the three backsight readings and the mean of the three foresight readings. It is not usually computed until the entire section is completed.

With three-wire leveling certain blunders cannot be detected. For example, a mathematical check to detect transposition of the foresight and backsight observations is not possible. Neither is a mathematical check to detect disturbance of the instrument between the backsight and foresight observations.

Instructions. The following instructions apply to a properly adjusted instrument without a micrometer (or with the micrometer locked in position), used with a pair of calibrated rods, each having one calibrated scale and a check scale. A spirit-level instrument must be shaded with an umbrella.

Record observations on NOAA Form 76-189, "Geodetic Leveling Three-Wire Observations." (See figs. 3-73 and 3-74 for sample records.) If observations are recorded in a computer, maintain a backup recording form as required by project instructions.

1. **EQUIPMENT RECORD:** At the start of each day or at any change of the observer, equipment, or collimation factor, prepare the survey-equipment record (line *40*). Include the date, the instrument code and serial number, the rod codes and serial numbers, the local time zone and time, whether temperature is measured in Fahrenheit or centigrade units, the collimation factor at the last check, and the initials of the observer, recorder, and rodmen. **CAUTION:** Each work day check all serial numbers against the actual equipment used.

2. Establish a balanced setup with the backsight rod plumbed on the beginning control point of the section, the foresight rod plumbed on a turning point, and the instrument set in line between them. Check for parallax. Using the instrument, check that the rods are plumb.

3. **BEGINNING RUNNING RECORD:** Immediately before the leveling begins, prepare the beginning running record (line *41*). Include the following items of information: The survey-point serial number of the beginning control point, the stamping on the point (or designation if no stamping exists), the local time, the air temperature, the wind code, the sun code, and the number of the rod on the control point. **CAUTION:** Check that the backsight rod is, in fact, on the point identified. The recorded stamping must correspond to that on the mark leveled. Check the survey-point serial number entered for the point.

4. **ROD 1:** Level the circular level on the instrument while pointing at rod 1. With a spirit-level instrument, use the tilting screw to center the bubble precisely in the tubular level. Read the intercepts of the three reticle lines with the precise scale, top to bottom. Estimate each reading to tenths of a rod unit.

5. When rod 1 is the backsight rod, record the readings in the backsight column, column B in the example. When rod 1 is the foresight rod, record the readings in the foresight column, column G. **CAUTION:** The recorder should watch to ensure that rod 1 is observed at the beginning of the setup. Be sure the readings are recorded in the correct column because there is no mathematical check for this type of error.

| NOAA FORM 76-189 (4-77) | | | | | | | | | | U. S. DEPARTMENT OF COMMERCE NATIONAL OCEANIC AND ATMOSPHERIC ADMINISTRATION | | | | DATE | | | | | | |
|---|----------------|-----|----------|-------------|--------------------------------|-----------------------|------|----------------|------|---|-------------|----------------|-------|-----------------------|------|-----|----------|--|--|--|
| GEODETTIC LEVELING THREE-WIRE OBSERVATIONS | | | | | | | | | | EXAMPLE | | | | Second Order, Class I | 10F1 | | | | | |
| * 4 | D | YR. | NO. | DAY | CODE | INSTRUMENT SERIAL NO. | CODE | ROD SERIAL NO. | CODE | ROD SERIAL NO. | 2 | TIME | | | | | | | | |
| 0 | 1 | 77 | 10 | 04 | 232 | 7762 | 313 | 7765 | 313 | 7766 | | | | | | | | | | |
| FROM | | | | | TO | | | | | TIME | | TEMPERATURE | | DU-SEWER | | | | | | |
| BM DESIGNATION 052477 | | | | | BM DESIGNATION 853 7562 A 1977 | | | | | 2 | BEGIN | END | 2 | BEGIN | END | W 1 | DU-SEWER | | | |
| TBM 853 7562 STAFF 6 FT | | | | | | | | | | R | 1100 | 1120 | A | 62 | 12 | | PDW | | | |
| BACKSIGHT | | | | | | | | | | FORESIGHT | | | | | | | | | | COMMENTS Reading check ± 9m Imbalance ± 25 m x 200 cm/m 1000 cm ± 333 ± 23 |
| SET UP | UPPER | | MEAN | BACK CENTER | S _U | (U+L) | | UPPER | | MEAN | BACK CENTER | S _U | (U+L) | | | | | | | |
| | MIDDLE | | | | S _L | Σ | | MIDDLE | | | | S _L | Σ | | | | | | | |
| | LOWER | | | | | | | LOWER | | | | | | | | | | | | |
| | Σ | | Σ | | | | | Σ | | Σ | | | | | | | | | | |
| 1 | 478.7 | | | | | | | 281.4 | | | | | | | | | | | | |
| | 474.1 | | 474.07 | | 4.6 | | | 276.6 | | 276.57 | | 4.8 | | As = -0.4 | | | | | | |
| | 469.4 | | | | 4.7 | 9.3 | | 271.7 | | | | 4.9 | 9.7 | | | | | | | |
| | 1422.2 | | 474.07 | | | 9.3 | | 829.7 | | 276.57 | | | 9.7 | | | | | | | |
| | 251.8 | | | | | | | 437.3 | | | | | | | | | | | | |
| 2 | 238.8 | | 238.80 | | 13.0 | | | 425.2 | | 425.17 | | 12.1 | | ± 1.7 | | | | | | |
| | 225.8 | | | | 13.0 | 26.0 | | 413.0 | | | | 12.2 | 24.3 | | | | | | | |
| | 2138.6 | | 712.87 | | | 35.3 | | 2105.2 | | 707.74 | | | 34.0 | | | | | | | |
| | 2105.2 | | 707.74 | | | 34.0 | | | | | | | | + 35.3 | | | | | | |
| | + 33.4 | | + 111.13 | Act | | 1.3 | | | | | | | | = 69.3 | | | | | | |
| | 3 | | | | | x 333 | | | | | | | | x 333 | | | | | | |
| | + 111.13 | | Act | | | 132.9 | | | | | | | | = 2307.69 | | | | | | |
| | 200 | | Act/m | | | 200 | | | | | | | | ÷ 20000 | | | | | | |
| | ΔH = + 0.556 m | | | | | Σ Δs = 2.2 m | | | | | | | | ÷ 10000 | | | | | | |
| | | | | | | | | | | | | | | S = 0.12 km | | | | | | |

Figure 3-73.—Three-wire leveling, half-centimeter rods.

| NOAA FORM 76-189 (4-77) | | | | | | | | | | U. S. DEPARTMENT OF COMMERCE NATIONAL OCEANIC AND ATMOSPHERIC ADMINISTRATION | | | | DATE | | | | | | |
|---|----------------|-----|----------|-------------|---------------------------------|-----------------------|------|----------------|------|---|-------------|----------------|-------|-----------------------|------|-----|----------|--|--|--|
| GEODETTIC LEVELING THREE-WIRE OBSERVATIONS | | | | | | | | | | EXAMPLE | | | | Second Order, Class I | 10F1 | | | | | |
| * 4 | D | YR. | NO. | DAY | CODE | INSTRUMENT SERIAL NO. | CODE | ROD SERIAL NO. | CODE | ROD SERIAL NO. | 2 | TIME | | | | | | | | |
| 0 | 1 | 80 | 12 | 04 | 217 | 10827 | 312 | 428 | 312 | 436 | | | | | | | | | | |
| FROM | | | | | TO | | | | | TIME | | TEMPERATURE | | DU-SEWER | | | | | | |
| BM DESIGNATION X 350 1957 | | | | | BM DESIGNATION X 350 RESET 1980 | | | | | 2 | BEGIN | END | 2 | BEGIN | END | W 1 | DU-SEWER | | | |
| | | | | | | | | | | R | 1550 | 1610 | C | 134 | 133 | 11 | RUB | | | |
| BACKSIGHT | | | | | | | | | | FORESIGHT | | | | | | | | | | COMMENTS Reading check ± 3cm Imbalance ± 25 m x 100 cm/m 500 cm = 332 ft ± 1.5 |
| SET UP | UPPER | | MEAN | BACK CENTER | S _U | (U+L) | | UPPER | | MEAN | BACK CENTER | S _U | (U+L) | | | | | | | |
| | MIDDLE | | | | S _L | Σ | | MIDDLE | | | | S _L | Σ | | | | | | | |
| | LOWER | | | | | | | LOWER | | | | | | | | | | | | |
| | Σ | | Σ | | | | | Σ | | Σ | | | | | | | | | | |
| 1 | 163.8 | | | | | | | 137.0 | | | | | | | | | | | | |
| | 154.9 | | 154.90 | | 50.8 | 8.9 | | 128.2 | | 128.20 | | 42.0 | 8.8 | As = 0.2 | | | | | | |
| | 146.0 | | | | 8.9 | 17.8 | | 119.4 | | | | 8.8 | 17.6 | | | | | | | |
| | 464.7 | | 154.90 | | | 17.8 | | 384.6 | | 128.20 | | | 17.6 | | | | | | | |
| | 170.0 | | | | | | | 145.0 | | | | | | | | | | | | |
| 2 | 161.5 | | 161.50 | | 53.0 | 8.5 | | 136.0 | | 135.97 | | 44.5 | 9.0 | -1.1 | | | | | | |
| | 153.0 | | | | 8.5 | 17.0 | | 126.9 | | | | 9.1 | 18.1 | | | | | | | |
| | 949.2 | | 316.40 | | | 34.8 | | 702.5 | | 264.17 | | | 35.7 | | | | | | | |
| | 165.7 | | | | | | | 154.9 | | | | | | | | | | | | |
| 3 | 156.9 | | 156.87 | | 51.3 | 8.8 | | 145.9 | | 145.90 | | 47.8 | 9.0 | -0.3 | | | | | | |
| | 148.0 | | | | 8.8 | 17.7 | | 136.9 | | | | 9.0 | 18.0 | | | | | | | |
| | 1419.8 | | 473.27 | | | 21.5 | | 230.2 | | 410.07 | | | 21.5 | | | | | | | |
| | 168.0 | | | | | | | 124.9 | | | | | | | | | | | | |
| 4 | 159.1 | | 159.07 | | 52.1 | 8.9 | | 116.7 | | 116.67 | | 38.0 | 8.2 | +1.4 | | | | | | |
| | 150.1 | | | | 9.0 | 17.9 | | 108.4 | | | | 8.5 | 16.5 | | | | | | | |
| | 1897.0 | | 632.34 | | | 70.4 | | 1580.2 | | 526.74 | | | 70.2 | | | | | | | |
| | 1580.2 | | 526.74 | | | 70.2 | | | | | | | | + 70.4 | | | | | | |
| | + 316.8 | | + 105.60 | cm | | 0.2 | | | | | | | | = 140.6 | | | | | | |
| | 3 | | | | | x 332 | | | | | | | | x 332 | | | | | | |
| | + 105.60 | | 0 cm | | | 66.4 | | | | | | | | = 46679.2 | | | | | | |
| | 100 | | cm/m | | | 100 | | | | | | | | ÷ 10000 | | | | | | |
| | ΔH = + 1.516 m | | | | | Σ Δs = 0.7 m | | | | | | | | S = 0.47 km | | | | | | |

Figure 3-74.—Three-wire leveling, centimeter rods.

6. **READING CHECK:** Compute and record in column E (or K) the half stadia intervals. The upper interval, s_U , is the difference between the upper and middle readings, and the lower interval, s_L , is the difference between the middle and lower readings. Check that $s_U - s_L$ is no more than 0.3 rod unit. If it exceeds this tolerance, reobserve rod 1, beginning at step 4.

7. If the tolerance is satisfied, compute the full stadia interval, $s_U + s_L$, and record it in column F (or L). Compute the sighting distance and check that it is within the tolerance for the survey. For convenience, if recording on paper, convert the tolerance to a permissible stadia interval in rod units, and use this value to make the check. For example, if the rod units are centimeters, the stadia factor is 333, and the tolerance for sighting distance is 60 m, then the tolerance for the stadia interval is 18.0 cm $[(60 \text{ m} \times 100 \text{ cm/m}) \div 333 = 18.0 \text{ cm}]$

8. Compute the mean of the three readings. The mean may be computed quickly by examining the last digits of s_U and s_L . If s_U is three tenths larger than s_L , add 1.0 to the middle reading. If s_U is two tenths larger, add 0.7. If s_U is one tenth larger, add 0.3. If s_U equals s_L , the middle reading is the mean. Similarly, if s_U is three tenths smaller than s_L , subtract 1.0 from the middle reading. If s_U is two tenths smaller, subtract 0.7. If s_U is one tenth smaller, subtract 0.3. The mean always ends with the numeral "0", "3", or "7".

9. **BACK CHECK:** Read the intercept of the middle reticle line with the back scale. Record the reading in column D. The recorder or the person holding the umbrella must convert the reading to the units of the precise scale, then compare the result to the reading of the middle reticle line made in step 4. If no blunders have been made, sum the three readings together with the sum from the previous setup. Also, sum the means computed so far. **CAUTION:** Do not move the backsight rod and turning point until the data for the entire setup have been checked.

10. **ROD 2:** Point the instrument toward rod 2. Do not relevel the circular level. With a spirit-level instrument, recenter the bubble in the tubular level. Make three readings as before.

11. When rod 2 is the foresight rod, record the readings in the foresight column, column G. When rod 2 is the backsight rod, record the readings in the backsight column, column B. **CAUTION:** Again, check that the readings are recorded in the correct column.

12. Perform the reading check and back check as in steps 6 through 9.

13. Compute and check the imbalance (backsight distance minus foresight distance.) If it exceeds the tolerance for the survey, reobserve the setup, changing the position of the foresight rod or the instrument.

14. Check the accumulated imbalance for the section. If it is more than the tolerance for one setup, alert the pacer or rodmen so the next setup or setups can be adjusted accordingly.

15. **NEXT SETUP:** Advance to the next setup. Leave the former foresight rod (and turning point) in place to

become the next backsight rod. Move the former backsight rod and turning point to the next foresight position. Set the instrument on a line halfway between the two rods. **CAUTION:** Do not remove the former foresight rod from its turning point. Keeping it centered on the point, pivot it to face the instrument.

16. Repeat steps 4 through 15. Remember to read rod 1 first on every setup, regardless of whether it is in the backsight or the foresight position.

17. As the unit approaches the end of the section, if required, adjust the sighting distances to make an even number of setups for the section. The final setup should have rod 1 on the control point and rod 2 on the last turning point. An even number of setups is not required if all graduations of both rods have been calibrated by laser interferometry (sec. 3.4.2), which permits sufficiently accurate correction for index error.

18. After the last setup, compute and record the elevation difference for the section. Total the backsight readings and the foresight readings separately. Subtract the foresight total from the backsight total, and divide by 3. Similarly, total and subtract the backsight and foresight means. The two elevation differences should agree within 1.0 mm (0.003 ft).

19. Compute and record the length of the section. Total the backsight and foresight stadia intervals, multiply the result by the stadia factor, and convert it into meters. A summary of the three-wire procedure is given in table 3-6.

20. **ENDING RUNNING RECORD:** After completing the last setup of the section, prepare the ending running record (line *41*). This includes the survey-point serial number of the ending control point, the stamping on the point (or designation if no stamping exists), the local time, the air temperature, the wind code, and the sun code. Compute and record in meters the elevation difference of the section. Compute and record in kilometers the length of the section. Record the number of setups. If the leveling is the second running of a section, check for closure. (See sec. 3.7.7, "Releveling and closing sections.") **CAUTION:** Make sure the stamping entered for the ending point corresponds exactly to that on the mark on which the rod is resting.

3.7.4 Precautions to Take at Control Points

The beginning and ending control points of a section are critical in three ways. First, the marks must be positively identified. Second, the control points must be clearly defined and properly used. Third, the stability of a mark that represents the end of a previous day's or week's leveling must be proved.

Identify the mark. Because of the proliferation of survey marks of all types and the possibility that control points may have been relocated without the knowledge of the leveling unit, each mark must be identified carefully. At the start of a section, identify only the

Table 3-6.—Summary of three-wire leveling procedure

During each setup

- 1 Balance setup
- 2 Point instrument at rod 1
- 3 Level instrument and plumb rods
- 4 Read three reticle lines, top to bottom
- 5 Check half-stadia intervals and sighting distance
- 6 Read back scale: middle reticle line
- 7 Check mean of three readings against back-scale reading
- 8 Point instrument at rod 2
- 9 Read three reticle lines, top to bottom
- 10 Check half-stadia intervals and sighting distance
- 11 Read back scale: middle reticle line
- 12 Check mean of three readings against back-scale reading
- 13 Check imbalance and accumulated imbalance
- 14 Move to next setup

beginning mark; identify the ending mark when the section is completed. When the rodman prepares the control point for the leveling rod, he or she should call out the stamping to the recorder. The recorder enters the stamping, as it is called out, and the corresponding survey-point serial number as it is given in the log.

Locations where marks may be easily misidentified include triangulation stations and tide or water-level stations. At these locations, marks are set in clusters, often only a few meters apart. To further complicate matters, many marks may be stamped with similar designations, perhaps bearing only one or two inconspicuous symbols to distinguish them. Level through such clusters with care. Avoid unnecessary spurs. For example, at a triangulation station, do not level separate spurs to the reference marks. Instead, level from one reference mark to the station, to the next reference mark, and then to the next control point in the line (fig. 3-75).

If an apparent mistake or duplication is found in the log, investigate and correct it, adding a thorough explanation on the recording form for leveling. Some examples follow: If a control point is not found where it was plotted on a map, explain the situation and plot the point correctly. If a survey-point serial number has not been assigned in the log, use "0000" and note the fact. If a mark does not exactly match the description given in the log, check for a similar mark in the vicinity, and be sure to record the stamping that appears on the mark actually leveled.

Sometimes the unit may find a control point that is not indicated in the log. In general, do not level to such a point unless it is already included in the national network. All control points in the national network should have been accounted for by the reconnaissance team. If, in fact, the point represents an accidental omission by the mark setter or an amendment to the original leveling route, it should be leveled. Prepare a complete description in the standard format (sec. 2.4.4) and submit it with the leveling data.

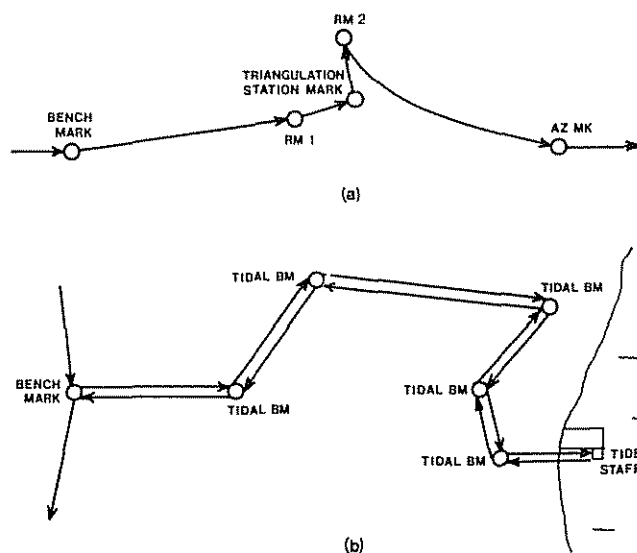

Figure 3-75.—Leveling routes through a cluster of control points at a triangulation station (a) and a tide station (b).

Identify the control point. The leveling rod must rest on a clearly defined point. On a horizontal surface, the control point is the highest point of the mark. On a vertical surface, it is at the intersection of a pair of crossed lines (the exact center of a bench mark disk, fig. 3-76). The one exception to these rules occurs if some other point is specifically defined in the description of the control point. If any other point is used, describe it clearly in the leveling records.

Center the base plate of the rod precisely on the control point. If the point is in a location that does not permit this, use the center of the back or front edge before resorting to a corner of the base plate. If a mark is very flat, use a spacer placed exactly at the center. Sometimes the concrete around a disk may prevent centering or rotating the rod. Use a spacer in this situation as well.

A spacer ("plug") is a calibrated cylinder of solid metal, often magnetized. (If observations are recorded on a magnetic tape or disk, keep the spaces away from the recording media.) The spacer is used to elevate the rod above the control point in a restricted setting, thus permitting the rod to be centered and rotated. When a spacer is used, either the same spacer or another one identical in height must be used on the turning point of the same setup. Make a note on the recording form whenever a spacer is used.

To use a single spacer, place it under the backsight rod of the setup. After reading the backsight, low scale, place the spacer under the foresight rod. After the foresight readings, return it to the backsight rod for the final reading. The height of the spacer is included in

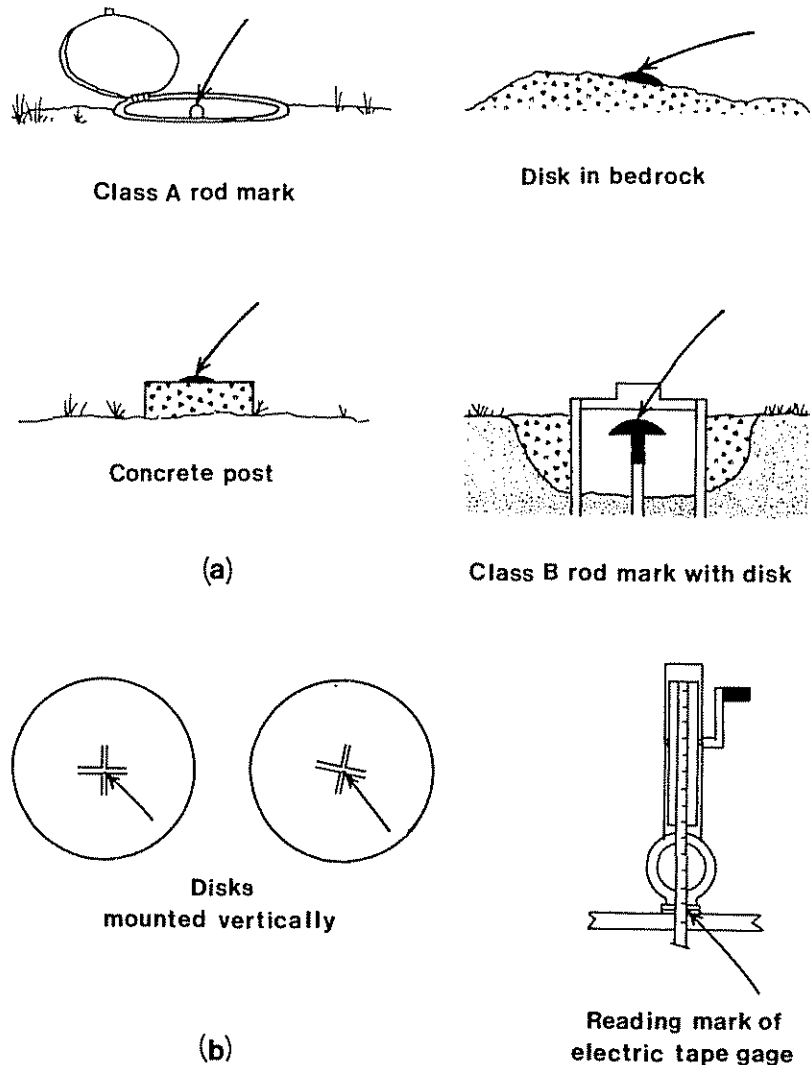

Figure 3-76.—Control points on horizontal surfaces (a) and vertical surfaces (b).

the observed heights of both the backsight and the foresight; therefore, the extra height is canceled when the elevation difference is computed (fig. 3-77).

A pair of spacers, manufactured and calibrated to agree in height within 0.05 mm (0.0015 ft), can be used simultaneously for a more efficient operation.

Set a check point. The elevation of the control point at the end of a line segment leveled during one day must remain unchanged until leveling resumes the next day. To ensure this, set a check point wherever a day's leveling is not connected to previous leveling. The check point should be a solid point, clearly defined, and not on the same structure as the control point. Locate it no more than one setup away. Examples of check points include a marked point on a building foundation, a double-headed nail driven into a telephone pole, or a marked point on a rock outcrop.

From a balanced setup between the control point and the check point, read the low scales of each rod. Write the readings in the "remarks" column of the recording form and compute the elevation difference, control point

to check point. Also, write the difference on the field abstract for future reference.

When resuming work, observe a new difference between the control point and the check point, recording the difference as before. It should not differ from the first difference by more than 1.0 mm (0.0030 ft). If this check indicates movement has occurred (or that the rod was incorrectly placed on the control point), the original section leveled to the questionable point should be releveled in the opposite direction and closed.

If leveling is single run, set check points as follows: When leveling forward on the line, set one check point at the end of work each day; when leveling backward, set one check point at the start of work and set another at the end of work only if the previous day's leveling is not connected.

If leveling is double run, a check point need only be set at the end of a completed segment of line. It is practical to level the last section of the day in only one direction, setting no check point. The next day, level the section in the opposite direction, thus checking the stabil-

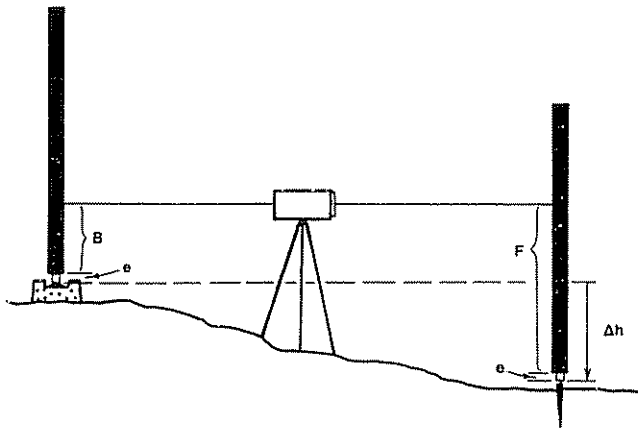

Figure 3-77.—When using spacers the height, e , of each spacer cancels when the elevation difference, Δh , is computed: $\Delta h = (B + e) - (F + e) = B - F$.

ity of the end mark, as well as satisfying the double-run requirement.

3.7.5 Leveling to Awkward Control Points

In the National network many existing control points are located where they cannot be easily leveled. These awkward points fall into two categories: (1) those mounted or etched on vertical surfaces, and (2) those mounted or etched on horizontal surfaces in positions requiring unusual equipment or procedures.

Locations where a control point may be found on a vertical surface include foundations and footings of large buildings and headwalls, and abutments of highway overpasses. The best way to level to a point in such a

location is to intercept it directly. Another way is to use a short scale in lieu of the standard leveling rod.

Awkward locations for points on horizontal surfaces include the following: the top of a post or pedestal (too high to plumb the leveling rod properly and not large enough to support a rodman); a point less than 3 m (the length of a leveling rod) below an overhang or ceiling; and the underside of an overhang or eave. The best way to level to a point in the first location is to set the line of sight tangent to the highest point of the mark. At the second location, use a short rod. The third location requires that a rod be read while placed upside down against the point. Figure 3-78 illustrates each of these cases.

The following instructions explain how to level to awkward points.

Level directly to the point Follow the micrometer leveling procedure. (See fig. 3-79 for an example.)

1. During the setup, which includes the control point, adjust the instrument height so that when the instrument is leveled the line of sight is within one full turn of the micrometer (one rod unit) of the control point.

2. To make the low-scale reading on the point, intercept it with the middle reticle line. Read the micrometer. Record the observation as "000." plus the micrometer reading.

3. To make the stadia reading, hold a short scale at the point. Read a stadia intercept on the low scale.

4. To make the high-scale reading on the point, intercept it with the middle reticle line again. Read the micrometer. Record the reading in the remarks column, and add the appropriate rod constant to the reading. Enter the sum as the high-scale reading.

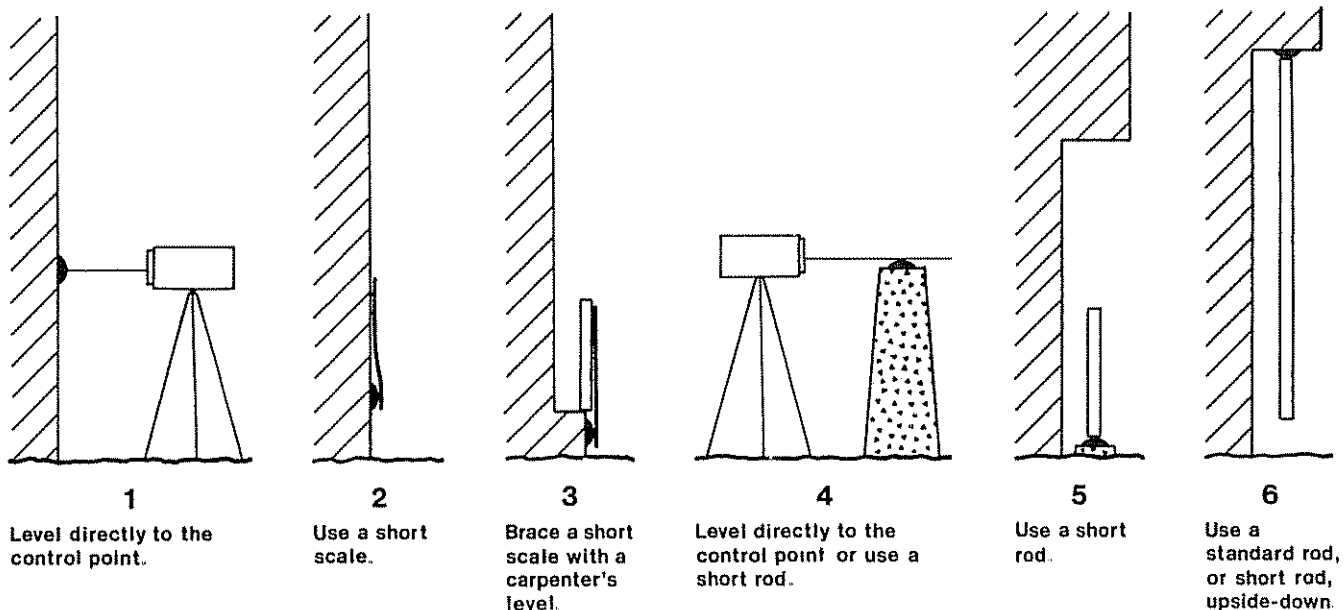

Figure 3-78.—Leveling to awkward control points.

3.7.6 Tide and Water-Level Stations

Leveling connections from the national network to tide and water-level gages are important in two ways: The connections make it possible to refer elevations to the surface of a local body of water, and they provide a means to monitor relative changes in the levels of rivers, lakes, and oceans. Leveling to connect the national network to a gage is distinguished from leveling to monitor movement of the gage relative to the control points at the station. The latter type of work, conducted by the National Ocean Survey, is discussed in *Publication 30-1, Manual of tide observations* (Coast and Geodetic Survey 1965) and *User's Guide for the Establishment of Tidal Bench Marks and Leveling Requirements for Tide Stations* (Bodnar 1977).

A description and sketch of each station to be leveled should be attached to the log, showing the exact location of the points to be leveled and a recommended route through them. (See sec. 2.3.4, "Tide and water level stations.") Since the points are numerous and the stampings sometimes duplicated, identify the points with extreme caution. Level to the staff or gage and make a water-level measurement according to the following instructions.

Before leveling to a tide or water-level station, make an appointment to meet the station observer at the station. The station observer should be present to calibrate the water-level recorder.

Staff. Level to a staff by using a well-defined point on the staff to support the leveling rod, or level to the staff directly. The first method is preferred, but the second may be used if the staff is inaccessible.

Mounted on most tide staffs is a rod stop, a galvanized metal angle with a round-head bolt through the top. The highest part of the bolt is the point on which to place the rod. If possible, confirm the location of this point with the station observer. Include the height of the point, above or below the zero of the staff, in the designation.

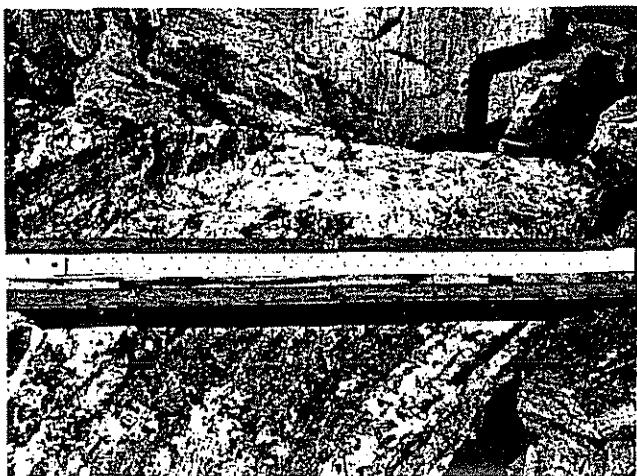

Figure 3-80.—Short scale.

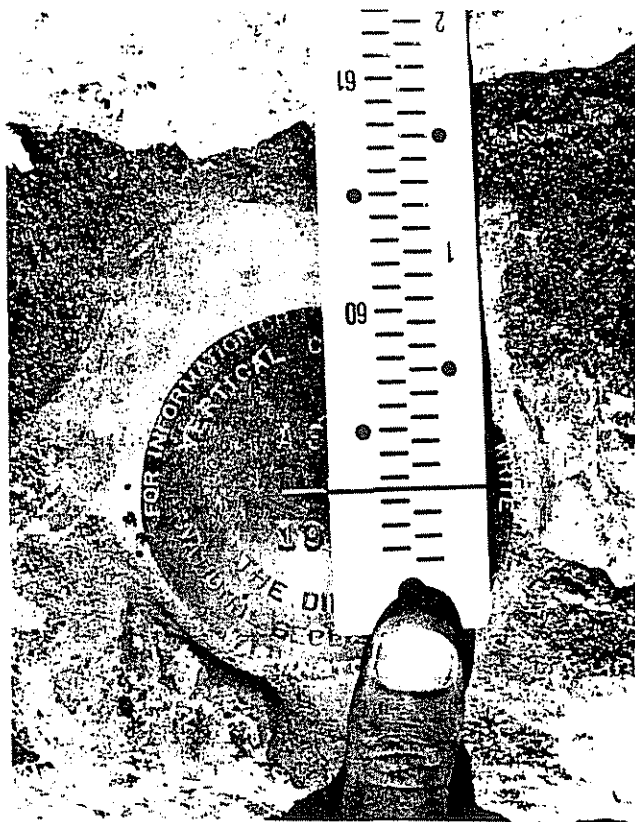

Figure 3-81.—Centering the index line of a short scale on a control point.

If no rod stop is available, or the staff is inaccessible, level directly to the staff. Follow the procedure described in the previous subchapter, using a convenient graduation as the control point. Include the graduation value in the designation (not in the readings). To make a stadia reading, count the number of staff graduations in the half stadia interval, estimating to tenths. Record this in the remarks column and convert it to rod units, then enter it as the stadia reading. For example, if the staff is graduated in tenths of feet and the rod units are half-centimeters, then 2.3 staff graduations are counted in the half stadia interval, corresponding to 0.23 ft. Multiply this by a conversion factor, 60.96 hcm/ft, to compute the stadia reading, 014.0 hcm.

Immediately after leveling to the staff, record on the recording form the water-level height in staff units. If possible, record the staff's identification date, which should be stamped on an attached brass tag.

Electric-tape gage. The electric-tape gage is usually located in a small house along with the water-level recorder. Level to the reading mark, directly if possible. It is usually a horizontal line, etched on the vertical edge of a metal plate supporting the electric-tape reel (fig. 3-76). Perform the accompanying water-level measurement as follows:

1. With one hand, hold the crank handle of the tape reel. With the other hand, release the ratchet pawl and hold it clear.

First, compute the difference, the misclosure, between the two elevation differences. Because they are opposite in sign, the misclosure is the sum of the backward running plus the forward running.

Then, compute the tolerance by the formula $T \times \sqrt{K}$, where T is the factor from table 3-1 for the order and class of the survey and K is the length of the section in kilometers. The length of the section is computed by totaling the distance leveled and dividing by the number of section runnings. For example, if the distance leveled in each running is 1.60 km and the survey is first order, class I, the tolerance is $3.00 \times \sqrt{1.60} = \pm 3.79$ mm.

If the misclosure is within the tolerance, additional runnings are not required. If it exceeds the tolerance, relevel and recheck the section to satisfy two criteria: (1) All runnings likely to contain blunders (as determined by the rejection procedure) are rejected, and (2) at least one forward running and one backward running are accepted. A standard rejection procedure is used to reject statistically unreliable runnings.

When releveling to close the section, alternate the direction of leveling on each running, to maintain an equal number of forward and backward runnings. If systematic error persists in the leveling, the mean of the elevation differences may be biased in favor of the running direction that is in the majority. Equalizing the number of runnings in each direction prevents this bias.

Notify the project office if more than four runnings are required to close the section. To prevent excessive releveling, check that the leveling rods are being placed on the control points correctly and check that the points themselves are stable. Record any unusual features of the points in the leveling data. Check and adjust the rods and the instrument, especially the circular levels. On subsequent runnings, try shortening the sighting distances, balancing setups more precisely, varying the routes, and changing the duties of the unit members. Try to make subsequent runnings when the air-temperature difference is negative and less than 1°C (2°F). (See sec. 3.6.1, "Measuring air-temperature differences.")

Rejection procedure. After three or more runnings of a section, check for agreement and reject blunders as follows. (See example in table 3-7.)

1. Compute the mean of all the runnings (disregard the signs), including those that have been rejected before.
2. Compute the differences between the mean and each running, the mean value minus each running value.
3. Compute the allowable difference from the mean. It is based on the order and class of the survey, the number of runnings that were meaned, and the length of the section. The formula is $t \times \sqrt{K}$, where t is the appropriate factor from table 3-1 for the order and class of the survey, and K is the section length in kilometers. For example, if the survey is first order, class I, four runnings were meaned, and the section length is 1.51 km, and the allowable difference is $2.33 \times \sqrt{1.5} = \pm 2.85$ mm.

4. Compare the differences from step 2 to the allowable difference. If any runnings exceed it, reject only the running that exceeds the allowable difference by the largest amount.

5. Check the runnings to see if there are at least one forward and one backward running remaining. If this is the case, and no running was rejected in step 4, the section is closed. If a running was rejected in step 4, compute a new mean with the remaining runnings and return to step 2. If only runnings made in one direction remain, relevel the section and begin again at step 1.

Notice that certain runnings, rejected when the number of runnings is three or four, may be accepted when the number increases. This is acceptable because the accuracy of the mean improves with a larger sample of data; it becomes easier to recognize if a running is different enough to be considered a blunder.

3.8 Field Records

Original records of field observations are the primary source of information for all future analysis and adjustment of a survey. As such field records must accurately and completely present the results and conditions of leveling. The records may include both data recorded on forms and printouts of data recorded in computer memory. To be incorporated into the National Geodetic Vertical Control Network, they must provide data sufficient to meet the requirements of the Federal Geodetic Control Committee, which are published in *Input Formats and Specifications of the National Geodetic Survey Data Base* (Pfeifer and Morrison 1980: vol. II, ch. 6). Whatever form is used, the records must be carefully preserved by the leveling unit until they are submitted to the project office. Their preparation and submittal are the subjects of this subchapter.

3.8.1 Recording Observations

Leveling observations can be collected by using one of two methods. Observations may be either (1) written on a recording form, or (2) keyed into computer memory and recorded on a magnetic tape or disk, supplemented with a backup form if required. The computer-recording method is preferred to reduce errors and to simplify checking and archiving the data. Nevertheless, both methods require that the recorder prepare clear, correct, and complete records.

When observations are written, the recording form serves both as a record and as a reminder of the checks and computations to be made. When observations are keyed, the backup recording form serves as a record to verify information that cannot be checked by the computer. Use standard recording forms, as illustrated in the figures in this manual.

Be sure to record correct identifying information. This cannot be overemphasized. Mistakes in any of the following entries will cause false elevation differences to be computed when leveling data are processed.

Table 3-7.—Example of rejection procedure for first-order, class II leveling

| Date | Direction (km) | Distance (m) | Elevation difference (mm) | Difference from mean | Explanation |
|-------|-------------------|-----------------|---------------------------------|-------------------------|--|
| 10/11 | F | 0 82 | -2 43152 | | Two runnings of a section are made Their difference is $B+F=6\ 00$ mm The tolerance is $3 \times \sqrt{0\ 82} = \pm 2\ 72$ mm. Since the difference exceeds the tolerance, the section is releveled |
| 10/12 | B | 0 83 | 2 43752 | | |
| 10/11 | F | 0 82 | -2 43152 | +1 67 | The mean of the three runnings and the differences from the mean are computed. The allowable difference is $2\ 10 \times \sqrt{0\ 82} = \pm 1\ 90$ mm. The second and third runnings are both outside the allowable. Rejecting the worst leaves only two forward runnings, so the section is releveled. |
| 10/12 | B | 0 83 | 2 43752 R | -4 33 | |
| 10/12 | F | 0 82 | -2 43052 | +2 67 | |
| | | | Mean=2 43319 | | |
| 10/11 | F | 0 82 | -2 43152 | +2 90 | The mean and differences are computed for all four runnings. The allowable is $2\ 33 \times \sqrt{0\ 82} = \pm 2\ 11$ mm. All are outside the allowable. Rejecting only the worst, the third running, a new mean is computed. The allowable for three runnings is, as before $\pm 1\ 90$ mm. Rejecting the worst, (the first) leaves only two backward runnings, so the section is releveled. |
| 10/12 | B | 0 83 | 2 43752 | -3 10 | |
| 10/12 | F | 0 82 | -2 43052 R | +3 90 | |
| 10/13 | B | 0 82 | 2 43810 | -3 68 | |
| | | | Mean=2 43442 | | |
| | F | 0 82 | -2 43152 R | +4 19 | |
| | B | 0 83 | 2 43752 | -1 81 | |
| | B | 0 82 | 2 43810 | -2 39 | |
| | | | Mean=2 43571 | | |
| 10/11 | F | 0 82 | -2 43152 | +3 64 | The mean and differences are computed for the five runnings. The allowable is $2\ 48 \times \sqrt{0\ 82} = \pm 2\ 25$ mm. Rejecting the worst, a new mean is computed. |
| 10/12 | B | 0 83 | 2 43752 | -2 36 | |
| 10/12 | F | 0 82 | -2 43052 R | +4 64 | |
| 10/13 | B | 0 82 | 2 43810 | -2 94 | |
| 10/13 | F | 0 83 | -2 43812 | -2 96 | |
| | | | Mean=2 43516 | | |
| | F | 0 82 | -2 43152 R | +4 80 | |
| | B | 0 83 | 2 43752 | -1 20 | |
| | B | 0 82 | 2 43810 | -1 78 | |
| | F | 0 83 | -2 43812 | -1 80 | |
| | | | Mean=2 4632 | | |
| | B | 0 83 | 2 43752 | +0 39 | |
| | B | 0 82 | 2 43810 | -0 19 | |
| | F | 0 83 | -2 43812 | -0 21 | |
| | | | Mean=2 43791 | | |

The recorded stamping, or designation of each control point, and its corresponding survey-point serial number determine the order in which the line is abstracted. This order must correspond to the way the line was actually leveled.

The recorded date, time zone, and time must be accurate because observations are stored and sorted chronologically. Corrections for collimation error, refraction, tidal accelerations, and scale error are applied accordingly. Time zones should be coded according to the alphabetical system of the U.S. Navy. (See table 3-8 for the codes applying to North America.)

Finally, recorded descriptions of the equipment and the corresponding serial numbers determine which collimation and calibration corrections are to be applied. The make and model of rods and instruments should be specified by code if possible. (See sec. 3.2.2, "Equipment.")

Write observations and remarks neatly in ink. Never recopy original records. If a mistake is made when computing, draw a straight line through the error and write the correct value above it. (See fig. 3-71.) If a mistake is made when recording a rod reading, reobserve the

Table 3-8.—U.S. Navy time zone designations

| Standard time | Daylight time | Time meridian | Time Zone description | U.S. Navy designation |
|---------------|---------------|---------------|-----------------------|-----------------------|
| Atlantic | AST | Eastern | EDT 60W | + 4 Q (Quebec) |
| Eastern | EST | Central | CDT 75W | + 5 R (Romeo) |
| Central | CST | Mountain | MDT 90W | + 6 S (Sierra) |
| Mountain | MST | Pacific | PDT 105W | + 7 T (Tango) |
| Pacific | PST | Yukon | YDT 120W | + 8 U (Uniform) |
| Yukon | YST | AK/HI | HDT 135W | + 9 V (Victor) |
| AK/HI | HST | Bering | BDT 150W | +10 W (Whiskey) |

setup and record the new readings on a new line. Crossed-out or illegible readings in written data are like readings missing from a computer-recorded tape: the entire section must be rejected.

When computing, round results to the appropriate number of decimal places. Elevation differences should usually be expressed in meters to five decimal places (four decimal places in three-wire leveling). Distances should be expressed in meters to one decimal place or in kilometers to two decimal places. Some calculators do not automatically round the result when displaying fewer decimal places than were computed. If using such a calculator, look at one extra decimal place and then round the result. If the number to be rounded ends with the numeral "5", round to the nearest even number. For example, the collimation factor $+0.0135$ mm/m rounds to $+0.014$ mm/m, and the elevation difference -2.148145 m rounds to -2.14814 m.

Compute reading checks carefully. If they are computed incorrectly and one or more setups are accepted which do not meet the tolerance, the section must be releveled. This type of blunder can occur anytime that observations are written; it can also occur when preliminary information is stored incorrectly in a computer. The observer should check for such blunders as work progresses.

Use the "remarks" column (or computer comment lines) freely. Record any activity or event which may affect the quality of leveling, such as frequent failure of reading checks, unusual atmospheric conditions, or difficulties with the computer-recording equipment. Give a complete description of the situation: time at which the activity occurred, the setup number, what happened, and the way it was handled. Be specific. Include the names of personnel involved and the serial numbers of the affected equipment.

At the end of the day, the unit chief should check and initial the recorder's work. Be sure to check that the designations and survey-point serial numbers are correct, as well as the other identifying information. If mistakes are found that may require editing of a data tape or disk, do not attempt to correct them. Instead, note and explain the correction required on a comment record in the computer or on the appropriate backup form.

3.8.2 Computer-Recording Equipment

Portable computers have revolutionized recording procedures. Specially designed computer-recording equipment permits observations to be checked at the time they are made, nearly eliminating reading and recording blunders from accepted data. The equipment also permits all field observations to be stored in data packages that can be easily transferred to more powerful computers, simplifying the subsequent checks, correction, analysis, and adjustment of the data.

To obtain the greatest benefit from a computer, the equipment selected should meet the general requirements given in this section. To collect data reliably, the computer and its power supply must be maintained properly. To collect data accurately, the computer must be programed and operated correctly.

General requirements. Computer-recording equipment for leveling should be manufactured for the field environment. The equipment must withstand frequent exposure to dust, water, and vibration. It should be portable, weighing no more than 10 kg. It should be capable of operating continuously from an internal power supply for at least 6 hours and from both 115 V AC and 12 V DC external power supplies. It should not lose stored data if the power supply is interrupted or exhausted.

Data may be recorded and stored on a tape or disk, or in the computer memory. If recorded in memory, data must be easily retrieved for rapid transfer onto a tape or disk or by telephone into a central computer. The output format should be compatible with the computer facilities of the project office.

The computer should be programmable and should have an alphanumeric keyboard with a numeric cluster. The keyboard permits the stampings on control points to be entered in addition to survey-point serial numbers. It also permits direct entry of remarks and simplifies the coding of other information. The display should be easy to read and should have at least 32 characters. At least 20,000 bytes of memory should be available for storing both programs and data.

Maintenance. One person in the leveling unit (usually the recorder) should be responsible for maintaining the computer-recording equipment. Carefully follow the instructions provided with the equipment. Protect it from exposure to dust, water, and vibration. The more self-contained and rugged the equipment is, the better; however, it must still be kept clean and be handled with care.

Sticky or dirty keys on a computer keyboard make recording difficult. Protect the keyboard by taping a thin sheet of plastic over it. When leveling data are recorded on magnetic tapes or disks, the data are highly vulnerable to alteration or erasure caused by dirty recording apparatus. Therefore, learn the proper method for cleaning the equipment, and clean it at least weekly.

Data may also be altered or erased if the equipment is exposed to shock or excessive vibration during the recording process. As a result, do not transport the equipment while data are being recorded. When data are stored in the computer memory, dropping the equipment or striking it against objects may erase or render inaccessible the results of an entire day's work. For the same reason, keep magnetic material away from the computer and data packages.

Battery care. For computer-recording equipment to operate reliably, the batteries must be properly charged and maintained. The nickel-cadmium batteries used

in most portable computers should be recharged at regular intervals, either nightly or as instructed. They should be protected from overcharging by a voltage regulator. They should also be "cycled," or discharged completely and recharged, at least once a month and after a period of storage. They should be stored in a cool, dry place.

Built-in batteries, if properly charged, should provide enough power for a day's work. However, to prevent loss of time if they fail, keep two alternate power supplies available: a spare battery pack and a hookup to the battery of the leveling vehicle. Maintain the spare pack in the same way as the built-in batteries.

Data packages. For submittal to the project office, leveling data are normally stored on a tape or disk. Use a separate tape or disk to record each day's data. If data are recorded directly onto a tape, precondition the tape before work begins. Keep a supply of clean tapes in the leveling vehicle, in case a tape is defective. If data are stored in computer memory, print out or record the data onto a tape or disk immediately after the day's leveling is completed. Instructions for submitting data packages appear in section 3.8.4.

Programs. When recording observations into a computer, use only the standard programs specified in the project instructions. The recorder should become thoroughly familiar with the programs by studying accompanying documentation and instructions. Although knowledge of programming techniques is not essential, it is helpful when troubleshooting in the field.

Recording programs should prompt the recorder for the necessary data at the appropriate time in the observing routine. They should incorporate as many checks for blunders as possible. They should record observations twice on tapes or disks, to increase the chance of retrieving at least one complete set of observations if some data are destroyed or made inaccessible by imperfections in the system. For leveling data to be included in the National Geodetic Vertical Control Network, the programs should format the data as described in *Input Formats and Specifications of the National Geodetic Survey Data Base* (Pfeifer and Morrison 1980: vol. II, ch. 6).

Depending on the capabilities of the equipment, a system of programs can control the observing routine at one of three levels: the setup, the section, or the day.

The most basic system prompts the recorder for the observations, checks them for blunders, and records them at each setup. Using a backup form as a guide, the recorder must enter the running records for each section and the survey-equipment records for each day. Separate programs are used for each order and class of survey, and to observe and compute the collimation and compensation checks. Although this system nearly eliminates blunders at each setup, it allows blunders in section and equipment information to remain undetected in the field. Therefore, a backup recording form, such as shown in figure 3-70, must be maintained to permit verification of the data.

More blunders can be eliminated if the system includes prompts and checks for running records and survey-equipment records. In such a system the recorder must again select the appropriate program to use, but programmed control of the observing routine is extended to include the entire section.

The most sophisticated system should prompt for and check all the data collected by the leveling unit each day. Prompts should include the following: date, line number, survey-equipment record, daily equipment checks (such as the collimation check), weekly checks (such as the compensation test), running records, and observations. Subroutines, such as the collimation check, should be accessed by the master program when required. Constants, such as the collimation factor, should be computed and retained in computer memory from day to day. Separate options should be available for each order and class of survey. The results of multiple runnings of a section should be checked automatically.

Precautions. When using computer programs, the recorder must observe the following precautions.

Learn to glance at each displayed rod reading immediately after keying it and before entering it. Gross mistakes (such as misplaced decimal points and double-keyed numbers) may then be deleted and corrected before the entire setup is rejected.

Never write over or erase the data for a setup. Enter a remark if necessary. If a section must be terminated, enter a rejection record. Learn how to avoid erasing data accidentally. Learn how to reprogram the computer if the program or data are lost because of a battery change or other power failure.

Avoid using computer-recording equipment near a source of high-energy radio-frequency emissions. Depending on their frequency, such sources as air-navigation, television, and radio transmitters may interfere with normal computer operation.

3.8.3 Field Abstract

The field abstract is a complete summary of the elevation differences measured between the control points in a line. On the abstract, points are listed in the order in which they are connected by leveling. For every pair of points, the elevation differences from one or more runnings are recorded. These are added to the elevation assigned to the beginning point, to obtain the field elevation for each point on the line.

If all observations are written on recording forms, a field abstract must be prepared and submitted to the project office. If observations are recorded with a computer, the abstract, although not required, should still be prepared. Since observations must be submitted daily, the abstract provides the leveling unit with the only record of which sections require additional leveling and which portions of the line have been completed. Multiple runnings, check points, and ties can be recorded and checked on the abstract.

The abstract, by itself, is not an acceptable substitute for the actual observations, no matter how they are recorded. It must always be accompanied by the original recording forms or printouts of the original observations recorded on a computer.

Instructions For leveling to be included in the national network, use NOAA Form 76-188, "Geodetic Leveling Line Identification" (fig. 3-83), and NOAA Form 76-187, "Geodetic Leveling Field Abstract." A single-run portion of line (fig. 3-84) is abstracted in figure 3-85. A double-run portion of line (fig. 3-86) is abstracted in figure 3-87. Prepare and compute the abstract as follows:

1. Prepare a cover sheet for the abstract. Only the portions of the form that are circled in the example need be filled out by the leveling unit. When observers, recorders, rods, or instruments change, add the initials or serial numbers and dates of change to the form. Submit the abstract form to the project office when the leveling line has been completed.

2. On the abstract, enter the accession number for the line, if known. If the accession number is not available, enter the line number, job code, and project title. Enter the line title, corresponding to the direction of leveling. Be sure to circle the appropriate units of distance and elevation difference. Include this information on every sheet of the abstract.

3. On the first sheet, skip the first line. Enter the survey-point serial number and designation of the beginning point on the second line. Enter the beginning distance, 0.00, in column D. In column H, enter the adjusted elevation from the most recently published description of the point. If the point is new to the national network, do not enter a beginning distance or elevation until a point with a published elevation is leveled. The beginning point and elevation are normally assigned by the project office, as described in section 5.4.2.

4. Enter the results for each section on subsequent records. The ending point of one section must correspond to the beginning point of the next. Write the designation of the beginning point for a forward running on line *30*. Write the survey-point serial number and designation of the ending point on the line labeled "TO." As shown in columns C, D, E, and F, write the date, direction, distance, and elevation difference for each running. Always write the results of the first forward running on line *30*. If more than two runnings are made, write the designation of the ending point on the next available line labeled "TO."

5. Check that sections with more than one running are closed. Indicate rejected runnings with the letter "R" in red ink.

| NOAA FORM 76-188 (8-74) | | | | | | | | | | | | U.S. DEPARTMENT OF COMMERCE NATIONAL OCEANIC AND ATMOSPHERIC ADMINISTRATION | | | | | | | | | | | | | | | | |
|--|--|-----------|--|--------------------|----|------|----|------|------|-----|-------|--|---|---|----|------------------|--|-------------|---|-------------|---|-------------------------------|--|--|--|--|--|--|
| GEODETTIC LEVELING LINE IDENTIFICATION | | | | | | | | | | | | | | | | | | | | | | | | | | | | |
| HGZ NUMBER | | LINE PART | | FIELD SURVEY DATES | | | | | | | | | | | | TOLERANCE FACTOR | | STATE CODES | | PARTY CHIEF | | AGENCY RESPONSIBLE FOR SURVEY | | | | | | |
| | | | | YEAR | MO | DAY | TO | YEAR | MO | DAY | UNITS | | | | | | | | | | | | | | | | | |
| 10 | | L24133 | | 5 | R | 1976 | 05 | 11 | 1976 | 12 | 09 | MM | 3 | 0 | 11 | LA | | B | K | W | G | S | | | | | | |
| PROJECT/LINE TITLE | | | | | | | | | | | | | | | | | | | | | | | | | | | | |
| 11. LEVELING FOR CORPS OF ENGINEERS NEW ORLEANS DISTRICT | | | | | | | | | | | | | | | | | | | | | | | | | | | | |
| 12. LOTTIE TO 9.8 KM (6.1 MILES) W OF KROTZ SPRINGS | | | | | | | | | | | | | | | | | | | | | | | | | | | | |
| 13. | | | | | | | | | | | | | | | | | | | | | | | | | | | | |
| 14. | | | | | | | | | | | | | | | | | | | | | | | | | | | | |
| COMMENTS | | | | | | | | | | | | | | | | | | | | | | | | | | | | |
| 15. | | | | | | | | | | | | | | | | | | | | | | | | | | | | |
| 15. | | | | | | | | | | | | | | | | | | | | | | | | | | | | |
| TASK NUMBER | | | | | | | | | | | | RODS | | | | | | | | | | | | | | | | |
| R362 5200 | | | | | | | | | | | | 316-121178 | | | | | | | | | | | | | | | | |
| CHIEF OF PARTY | | | | | | | | | | | | | | | | | | | | | | | | | | | | |
| BKM | | | | | | | | | | | | 316-127951 | | | | | | | | | | | | | | | | |
| OBSERVERS | | | | | | | | | | | | | | | | | | | | | | | | | | | | |
| RLW | | | | | | | | | | | | | | | | | | | | | | | | | | | | |
| RECORDERS | | | | | | | | | | | | INSTRUMENTS | | | | | | | | | | | | | | | | |
| DBC | | | | | | | | | | | | 231-90825 | | | | | | | | | | | | | | | | |

Figure 3-83.—Leveling line identification.

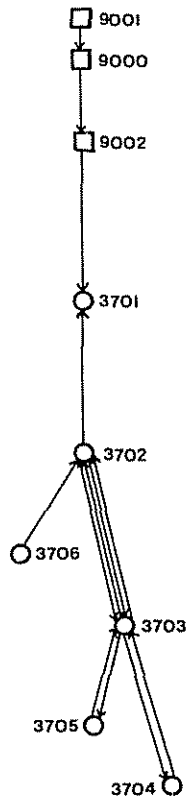

Figure 3-84.—Sketch of single-run leveling.

| EXAMPLE GEODETTIC LEVELING FIELD ABSTRACT | | | | | | | | | |
|---|------------------|---------------|----------------|---------------|-----|-----|-----|------------|--|
| NO. L | | LINE 368 NGVD | | SHEET 1 OF 15 | | | | | |
| TITLE JONESVILLE TO BARKERSVILLE, MT SINGLE-RUN FIRST ORDER CLASS II | | | | | | | | | |
| (A) | (B) | (C) | (D) | (E) | (F) | (G) | (H) | | |
| DISTANCE UNITS (M) | D.F.R. UNITS (M) | NO. OF SIGHTS | DISTANCE | Σ | Σ | Σ | Σ | | |
| | | | ft | | | | | | |
| 9001 | U.A. 03 | | 0.00 | | | | | | |
| 9002 | 3525 RESET, 1906 | 71 F | 0.16 + 5.89230 | | | | | + 5.89230 | |
| 3701 | 3525 RESET, 1906 | 71 F | 0.16 + 5.07362 | | | | | + 16.03362 | |
| 9003 | M. 16 | | 0.96 | | | | | 996.21612 | |
| 3702 | M. 16 | 71 F | 1.40 + 1.20312 | | | | | + 1.20312 | |
| 3703 | Z. 13 | | 2.36 | | | | | 997.41924 | |
| 9004 | M. 13 | 71 B | 1.31 - 0.15530 | | | | | 997.57454 | |
| 3704 | B. 04 | 71 F | 1.14 + 0.15501 | | | | | + 0.15501 | |
| | | 71 B | 1.13 - 0.16100 | | | | | - 0.16100 | |
| | | 71 F | 1.14 + 0.15612 | | | | | + 0.15612 | |
| | | 71 B | 1.14 - 0.15564 | | | | | - 0.15564 | |
| 3705 | M. 13 | | 5.30 | | | | | 997.73013 | |
| 3706 | M. 13 | 71 F | 1.52 - 0.67321 | | | | | - 0.67321 | |
| | | 71 B | 1.52 + 0.67304 | | | | | + 0.67304 | |
| 3707 | M. 11 | | 6.82 | | | | | 997.05701 | |
| 3708 | M. 13 | 71 F | 0.97 - 1.12310 | | | | | - 1.12310 | |
| | | 71 B | 0.97 + 1.12256 | | | | | + 1.12256 | |
| 3709 | M. 11 | | 6.21 | | | | | 996.60630 | |
| 9005 | B. 04 | | | | | | | + 1.12345 | |
| 3710 | B. 04 | 71 B | 0.96 - 1.12345 | | | | | - 1.12345 | |
| | | | 1.63 | | | | | 998.61777 | |

Figure 3-85.—Abstract of single-run leveling.

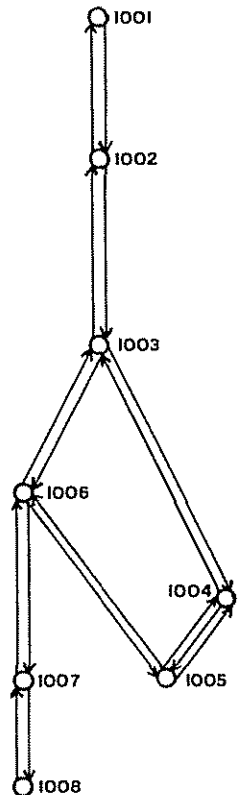

Figure 3-86.—Sketch of double-run leveling.

| EXAMPLE GEODETTIC LEVELING FIELD ABSTRACT | | | | | | | | | |
|---|------------------|---------------|----------------|---------------|-----|-----|-----|-----------|--|
| NO. L | | LINE 368 NGVD | | SHEET 1 OF 12 | | | | | |
| TITLE LONGVIEW TO 6.2 KM W OF HILLSIDE, LA DOUBLE-RUN FIRST ORDER CLASS II | | | | | | | | | |
| (A) | (B) | (C) | (D) | (E) | (F) | (G) | (H) | | |
| DISTANCE UNITS (M) | D.F.R. UNITS (M) | NO. OF SIGHTS | DISTANCE | Σ | Σ | Σ | Σ | | |
| | | | ft | | | | | | |
| 1001 | N. WASH. AZ. MK. | | 0.00 | | | | | 1.97151 | |
| 1002 | N. WASH. AZ. MK. | 71 F | 0.62 + 2.22450 | | | | | + 2.22450 | |
| | | 71 B | 0.62 - 2.22451 | | | | | - 2.22451 | |
| 1003 | B. 332 | | 0.80 | | | | | + 3.14445 | |
| 1004 | M. 142 | 71 B | 0.80 - 3.14423 | | | | | - 3.14423 | |
| | | | 1.42 | | | | | 7.37032 | |
| 1005 | F. 142 | 71 F | 1.17 - 3.45322 | | | | | - 3.45322 | |
| | | 71 B | 1.17 + 3.45168 | | | | | + 3.45168 | |
| 1006 | M. 14 | | 2.57 | | | | | 3.88787 | |
| 1007 | M. 14 | 71 F | 0.60 - 0.93591 | | | | | - 0.93591 | |
| | | 71 B | 0.61 + 0.93343 | | | | | + 0.93343 | |
| | | 71 B | 0.60 + 0.93465 | | | | | + 0.93465 | |
| 1008 | 203 RESET, 1167 | | 2.97 | | | | | + 2.97 | |
| 1009 | 203 RESET, 1167 | 71 F | 1.02 + 2.43776 | | | | | + 2.43776 | |
| | | 71 B | 1.03 - 2.43755 | | | | | - 2.43755 | |
| 1001 | Z. 331 | | 4.01 | | | | | 5.37281 | |
| 1002 | B. 142 | 71 F | 0.70 - 1.94763 | | | | | - 1.94763 | |
| | | 71 B | 0.68 + 1.94789 | | | | | + 1.94789 | |
| 1003 | Z. 331 | | 2.10 | | | | | 5.39258 | |
| 1004 | Z. 331 | 71 F | 0.82 + 3.22449 | | | | | + 3.22449 | |
| | | 71 B | 0.82 - 3.22487 | | | | | - 3.22487 | |
| 1005 | T. 84 63 | | 2.56 | | | | | 8.61726 | |
| 1006 | T. 84 63 | 71 F | 0.45 - 0.87508 | | | | | - 0.87508 | |
| | | 71 B | 0.51 + 0.87518 | | | | | + 0.87518 | |
| 1007 | A. 12 | | 2.37 | | | | | 8.34213 | |

Figure 3-87.—Abstract of double-run leveling.

6. Compute the mean of the accepted elevation differences for each section. Write the mean in column H, on the same line as the first forward running. Assign to the mean the sign of the forward running.

7. If there are two runnings, compute the difference in millimeters between the forward and backward runnings. Enter the difference in column G, with the sign of whichever number is smaller. If there are more than two runnings, compute the difference between the means of the forward and backward runnings.

8. Draw a box in red ink around every spur of the line, as shown in the example. For a spur-on-a-spur, draw an additional, nested box. If any sections connect to form a loop, show the longer route as a spur and the shorter route as part of the main line.

9. To the beginning distance, add the shortest distance for each of the sections leveled so far. Write the total in column E, on the dark line across from the designation of the point leveled to. When the end of a spur is reached, be sure to return to the point at the base of the spur to continue computing the distance along the main line.

10. Similarly, to the beginning elevation add the elevation differences of the sections leveled so far. Write the total in column H, on the same line as the distance. When the end of a spur is reached, return to the point at the base of the spur to continue computing the elevations of points on the main line. Total column G in the same manner.

11. Start subsequent sheets of the abstract on the first line, beginning with the point from the last line of the previous sheet.

3.8.4 Submitting Records to the Project Office

The unit chief is responsible for field records until they have been submitted to the project office. Submit records of observations daily. Submit completed abstract sheets weekly, together with the weekly status reports.

Package each day's records separately. Thus, if a package is lost or damaged, only one day's work at most need be repeated. Label the package with the following information: accession number or line number, date, initials of the unit chief, and, if data are recorded on a tape or disk, the serial number of the recording equipment. If many units are operating from the same project office, each unit should use labels of a unique color, so the data packages can be easily distinguished.

When working near the project office, submit records in person at the end of work each day. When working at some distance from the office, transmit observations recorded in a computer directly over a telephone line.

Send other types of records, including backup material (duplicates of transmitted data) by certified mail. Retain the receipts and send them with the weekly status report. Arrange the work schedule to allow visits to the post office when the facility is open. If this is not practical, send records by first class mail. When records are needed immediately, as at the end of a project, make special arrangements to send them to the office by courier or express mail.

Magnetic tapes and disks. Data recorded on magnetic tapes or disks are particularly vulnerable to alteration or loss. This may occur especially if they are stored for long periods under field conditions or exposed to X-rays or strong magnetic fields while enroute to the project office.

If data packages must be collected and stored in the field for any length of time, keep them in a rigid, non-magnetic container. When they are sent through the mail, enclose them in an appropriate mailer. Magnetic tapes may be sent in aluminum boxes and placed with the accompanying backup forms inside preaddressed, padded envelopes. Magnetic disks should be similarly packaged.

3.9 References

- Bodnar, Jr., A. N., 1977: *User's Guide for the Establishment of Tidal Bench Marks and Leveling Requirements for Tide Stations*. National Ocean Survey (C233), NOAA, Rockville, Md. 20852 (in press).
- Coast and Geodetic Survey, 1965: *Manual of tide observations. Publication 30-1*, National Ocean Survey (C233), NOAA, Rockville, Md. 20852, 77 pp.
- Federal Geodetic Control Committee, 1974: *Classification, Standards of Accuracy, and General Specifications of Geodetic Control Surveys*. 14 pp. (Sold as a set with the following companion publication).
- Federal Geodetic Control Committee, 1975, revised 1980: *Specifications to Support Classification, Standards of Accuracy, and General Specifications of Geodetic Control Surveys*. Superintendent of Documents, U.S. Government Printing Office, Washington, D.C. 20402, 50 pp.
- Greenawalt, B. and Floyd R. P., 1980: *National Geodetic Survey Operations Manual*. NGS Operations Division, NOAA/NOS, Rockville, Md. 20852 (unpublished manuscript).
- Pfeifer, L. and Morrison, N. L., 1980: *Input Formats and Specifications of the National Geodetic Survey Data Base*, vol. II: Vertical control data, Federal Geodetic Control Committee. National Geodetic Information Center, NOAA/NOS, Rockville, Md. 20852, 136 pp.

Chapter 4

RIVER OR VALLEY CROSSING

4.1 Introduction

In geodetic leveling, when the sighting distance and setup imbalance cannot be confined to the maximum specified for the order and class of the survey, a special procedure must be followed. Because it is most commonly required when a line of leveling crosses a river, the procedure is termed a river crossing. However, the procedure may be required over any type of terrain. In the following paragraphs, general procedures and requirements for a river crossing are explained. Detailed instructions for two river-crossing routines are presented in the remainder of the chapter.

Leveling errors that are a function of sighting distance are greatly magnified when an unusually long sight is observed, as shown in figure 4-1. The graduations on a geodetic leveling rod either cannot be seen or do not provide a sufficiently definite image, especially when shimmer is present. As a result, pointing error is greatly increased. Since the sighting distances of such a setup usually cannot be balanced, the effects of collimation error and curvature cannot be limited in the usual manner. (See sec. 3.1.2, "Leveling instrument.") Furthermore, even if the setup can be balanced, refraction may be large and unpredictable because of variations in the atmospheric conditions along the lines of sight, particularly if the line of sight passes over water.

Intercepting targets. To reduce pointing error when the sighting distance exceeds the limits for the order and class of the survey, a series of repeated scale readings should be made for each required observation. Pointing error may be further reduced by observing the crossing under favorable environmental conditions. Even so, a scale with line graduations does not provide an image which can be intercepted with sufficient precision at sighting distances greater than about 80 m (260 ft). Similarly, a scale with 1-cm block graduations does not provide a sufficiently precise image at distances over about 160 m (530 ft).

A better image is provided by a target or directional light, attached to the rod or other vertical support. A target should provide an image similar in size to that of a scale graduation viewed at about 50 m (165 ft) through the instrument. It should have a sharply defined shape and be symmetrical about the horizontal axis. An isosceles triangle is practical because the slopes of the sides define the center of the target throughout a wide range of sighting distances.

A precise method for making scale readings employs two targets. One target is placed above and the other below the point where the horizontal line of sight is estimated to intercept the support. The line of sight is then tilted by the amounts necessary to intercept each target and to return to a horizontal position. The inter-

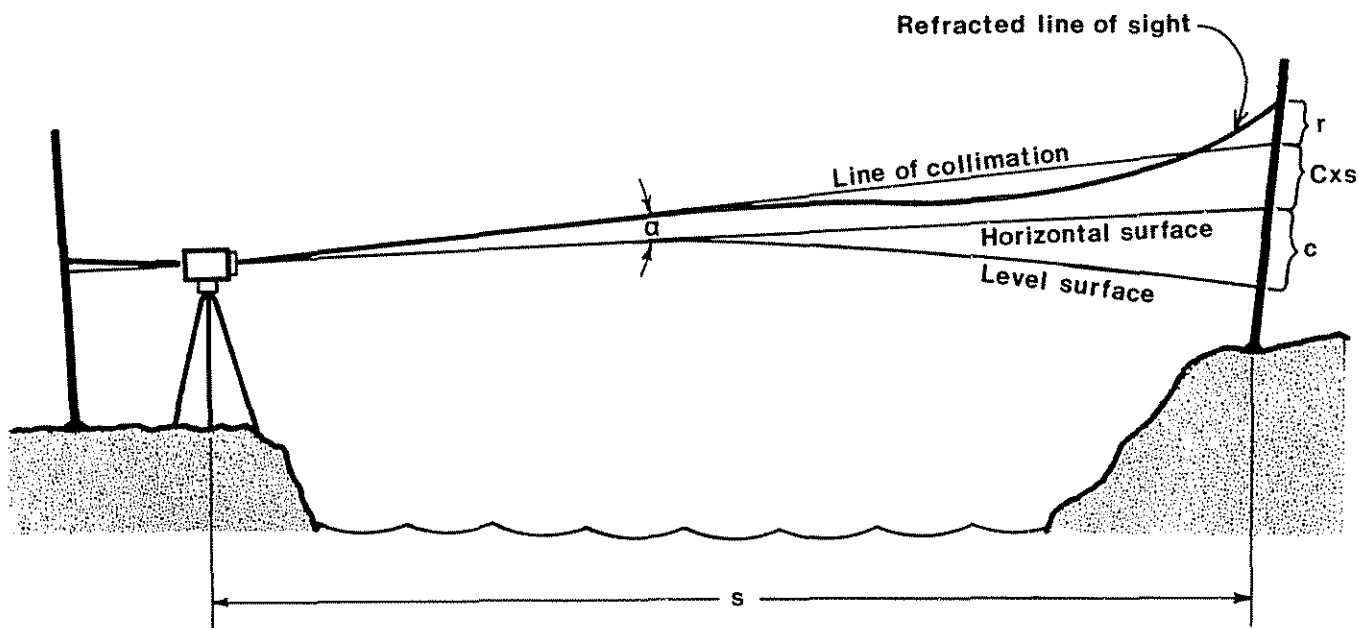

Figure 4-1.—Curvature, c , refraction, r , and the effect, $C \times s$, of collimation error, α , are magnified by a long sighting distance.

cept of the horizontal line of sight is computed from the proportional relationship between the distance intercepted on the support and the vertical angle of tilt, as illustrated in figure 4-2.

Three tilt measurements are made: (1) when the line of sight intercepts the upper target, a ; (2) when it is horizontal, r ; and (3) when it intercepts the lower target, b . The distance, $F-T$, between the unknown foresight intercept and the lower target is related to the angle, $b-r$, from lower tilt to horizontal in approximately the same ratio as the distance, D , between the targets is related to the angle, $b-a$, from lower to upper tilt (provided both angles are measured in radians):

$$(F-T)/(b-r) = D/(b-a).$$

Solving for the foresight intercept,

$$F = T + [D \times (b-r)/(b-a)].$$

The sighting distance, s , is computed without stadia observations by the following equation:

$$s = D / [\tan(b-r) + \tan(r-a)].$$

Since the angles of tilt are very small,

$$\tan(b-r) + \tan(r-a) \cong (b-r) + (r-a) \cong (b-a)_{\text{radians}}$$

Thus, to a sufficient approximation,

$$s = D / (b-a)_{\text{radians}}$$

This method for making scale readings is suitable for the longest sighting distances and is employed by the river crossing routines outlined in subchapters 4.3 and 4.4. For the most precise results, the angular difference $b-a$ should be between $100''$ and $250''$, and D should be no more than 1.0 m (3.3 ft). This is possible at sighting distances of 2.0 km (1.2 mi) or less.

Reciprocal setups. To limit the effects of curvature, two setups should be observed in opposite directions, one from each side of the crossing (fig. 4-3). Each setup should be unbalanced by the same amount, $\Delta s = s_B - s_F$. Such reciprocal setups are like those used in the 10-40 method for making a collimation check.

To compute the mean elevation difference, ΔH , the observed difference from the backward setup, Δh_B , must be subtracted from the observed difference for the forward setup, Δh_A . The effects of curvature then cancel. If the adjustment of the instrument does not change between the setups, the effects of collimation error cancel. The effects of refraction might be expected to cancel as well, but atmospheric conditions may change significantly, particularly over water, during the time required to move the instrument from one setup to the other. Another technique must be employed.

Simultaneous observations. To reduce the effects of refraction, the two reciprocal setups should be observed simultaneously through the same atmosphere. This condition can be approximated by employing two instruments, one on each side of the crossing, in positions that permit the lines of sight to be equal in length, parallel, adjacent, and at the same height above the water or ground. In addition, to ensure that the lines of sight pass over similar terrain, the bench mark and the instrument on one side should be positioned at distances from the edge of the water that are equal to the corresponding distances on the opposite side.

Such a set of simultaneous reciprocal observations is not enough, however, to limit the effect of any difference in the respective collimation errors of the instruments (α_1 and α_2 in fig. 4-4). The mean ΔH becomes

$$\Delta H = [\Delta h_{A1} - \Delta h_{B2} - (C_1 - C_2) \times \Delta s] / 2.$$

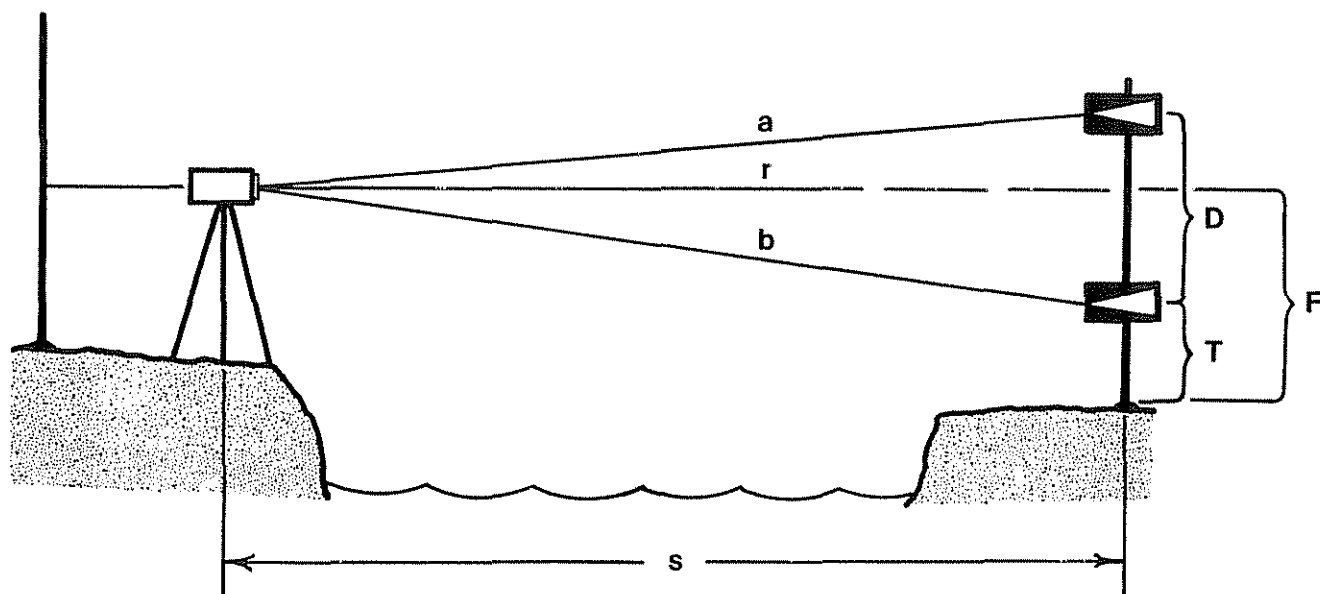

Figure 4-2.—Intercepting two targets to reduce pointing error.

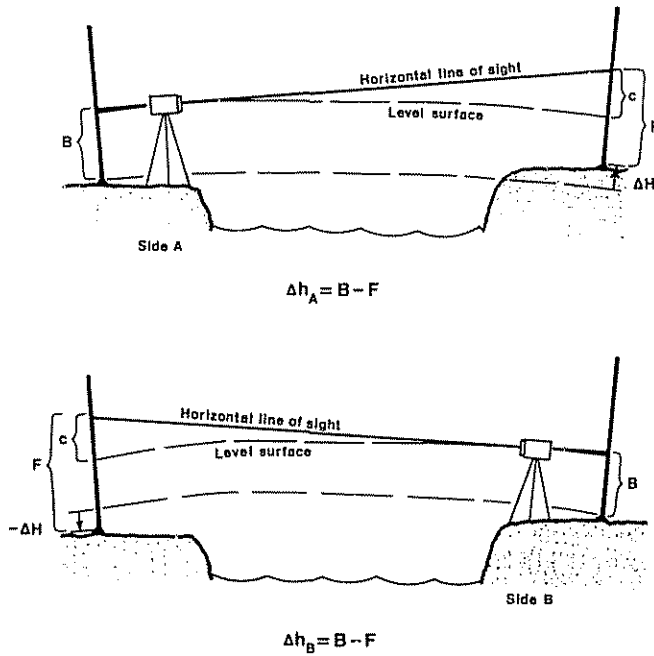

Figure 4-3.—The effects of curvature, c , cancel if a pair of reciprocal setups are observed and the results, Δh_A and Δh_B , are meaned.

Carefully determined values for collimation factors C_1 and C_2 might be used to correct the result, but at long sighting distances the magnitude of the correction is very large, as is the corresponding uncertainty.

Reciprocal collimation. To limit the effect of different collimation errors more effectively, four instruments with special attachments should be employed, two on each side of the crossing. During one set of simultaneous observations, each instrument pair should be repeatedly placed in reciprocal collimation; that is, the collimation error of one instrument should be adjusted to be equal and opposite to that of the other. (The lines of sight thus obtained are analogous to those provided by the two compensator positions of the NI 002, section 3.3.3. In this way, the mean collimation error of the instruments is minimized, and, as shown in figure 4-5,

$$\Delta H = (\Delta h_A - \Delta h_B) / 2.$$

This principle is applied in the observing procedure used with Zeiss River Crossing Equipment. (See sec. 4.3.)

Another technique for reducing the effect of different collimation errors, requiring only two ordinary instruments, is to interchange the instruments between two sets of simultaneous observations, each set including the setups illustrated in figure 4-4. The mean of the results of the sets is the elevation difference for the section:

$$\Delta H = [(\Delta h_{A1} - \Delta h_{B2}) + (\Delta h_{A2} - \Delta h_{B1})] / 4.$$

The collimation errors of the instruments can and do change somewhat when they are transported from one side to the other (as a result of temperature changes, vibration, and shocks during transport), increasing the uncertainty of the results. However, when less than first-order precision is required, a procedure employing this technique may be used. (See 4.4.)

Multiple runnings. One complete running of a river crossing, then, must include the equivalent of four setups: two sets of simultaneous reciprocal observations, with the instruments for one set providing lines of sight reciprocally collimated to those provided by the instruments for the other set. To permit a check of the results, a second complete running must be made. Although both runnings are computed as though they were observed in the forward direction, they constitute a double-run section because forward and backward levelings (the two reciprocal setups) are incorporated within each running. The results of the two runnings should close within the tolerance for the order and class of the survey, as described in subchapter 3.7.7.

4.2 Preparations

In most vertical control projects, river crossings occur infrequently. As a result, when a river crossing is necessary it requires special preparations. To ensure that it is conducted correctly and efficiently, the project director should first review the procedures outlined in

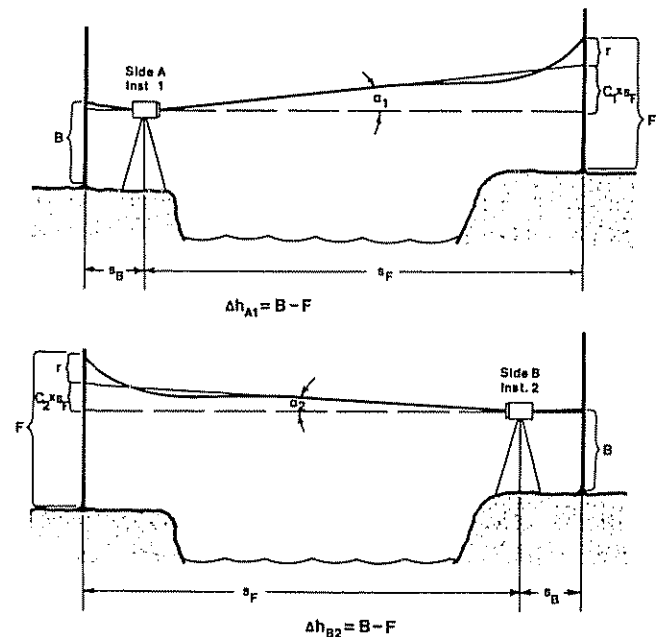

Figure 4-4.—The effects of refraction, r , cancel when the results of a set of simultaneous, reciprocal observations are meaned; however, the collimation error of one instrument, α_1 , is only partly offset by the collimation error of the other instrument, α_2 .

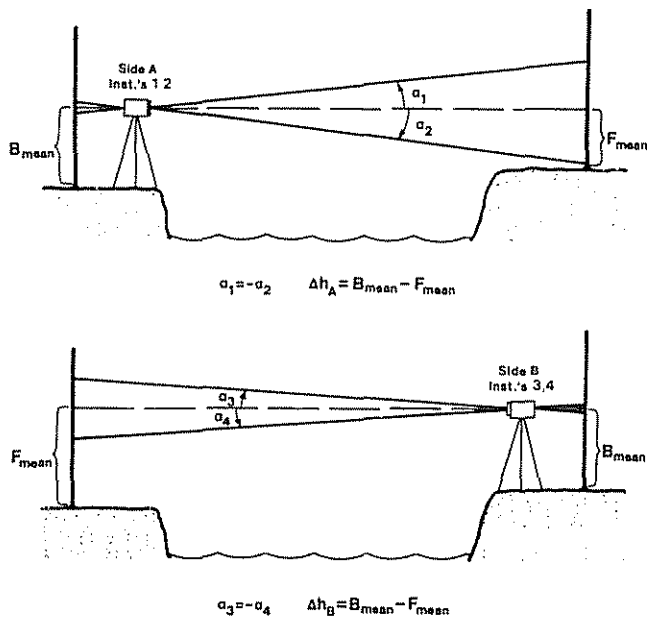

Figure 4-5.—Simultaneous reciprocal observations with four leveling instruments, the two instruments on each side having reciprocal collimation errors.

this chapter when planning the crossing. Then, the site must be selected and prepared, the necessary personnel and equipment must be assigned, and the work must be scheduled under suitable environmental conditions.

4.2.1 Reconnaissance and Mark Setting

An unusually long line of sight may be necessary when a leveling route crosses a river, the mouth of a bay, a deep ravine or valley, or a passage between two islands. When possible, the route should bypass such obstacles, taking advantage of bridges, dams, breakwaters, or even land exposed at low tide. However, if a river crossing is unavoidable, select a location to satisfy the following conditions:

1. The crossing is readily accessible to the leveling lines to be connected. Any connecting spurs or lines should be as short as possible.
2. The lines of sight, from one side to the other, are as short as possible.
3. The lines of sight are as high as possible, clearing water by at least 3 m (10 ft) and clearing land or objects (such as trees, buildings, or bridges) by at least 0.5 m (1.5 ft). Consider the possibility of difficulties resulting from wave action, vessel traffic, or extreme refraction. For crossings of 1.0 km (0.6 mi) or more, the lines of sight should be at least 4.5 m (15 ft) above the high-water line to ensure sufficient clearance.
4. The lines of sight pass over similar terrain. For example, avoid a site with a steep bank on one side and a gentle beach on the other.

Additional requirements for ordinary instruments. In most cases, special instruments are necessary for river crossings; however, ordinary leveling instruments may be used if all of the following conditions are satisfied:

5. The instrument has a mechanism for tilting and measuring the tilt of the line of sight. (Compensator instruments, such as the NI 002 and Nil, generally do not have such a mechanism.) Two such instruments and four targets must be available for this type of crossing.
6. Less than first-order precision is required for the survey.
7. The instruments can be quickly transported (preferably within an hour) from one side of the crossing to the other.
8. On each side, a bench mark can be set in such a position that a 3-meter leveling rod placed on the control point is entirely visible from the instrument station on the opposite side.

Setup specifications. On each side of the crossing, mark a location for the instrument station and set a permanent bench mark (sec. 2.4.2) to satisfy the following specifications. The setups for Zeiss River Valley Crossing Equipment are shown in section 4.3.2, "Setups," and the setups for ordinary equipment are shown in section 4.4.1, "Equipment and setups."

1. The lines of sight between each instrument station and the opposite bench mark should be equal in length, parallel, and at the same elevation.
2. The instrument stations should be at equal distances from the edge of the water or obstacle.
3. The bench mark should be 5 to 50 m (16-160 ft) from the instrument station. This backsight distance should be the same on each side of the crossing.
4. The bench mark should be no more than 1.0 m (3.3 ft) above or below the instrument station, to permit observation of a standard leveling rod. Furthermore, conventional geodetic leveling must be possible between the bench mark and the target station (which will be located next to the instrument station).

4.2.2 Personnel

Six individuals are normally required to conduct a river crossing: two observers, two recorders, and two rodmen. If an extra truck and equipment are available, a leveling unit assisted by one or two additional persons may perform the crossing. The unit chief coordinates the overall operation and serves as observer or recorder for one side. If two leveling units perform the crossing, one unit chief should be designated as the coordinator, and advantage should be taken of the opportunity to train the extra individuals present.

Observers. The observers must follow the appropriate crossing procedures, paying particular attention to the details of intercepting the targets. They must ensure that observations on each side are made simultaneously. Before leaving the site, the observers must verify that all required measurements have been accurately recorded.

Recorders. Recorders should ensure that all steps in the crossing routine are completed in the correct sequence. They must be thoroughly familiar with procedures for recording and computing the data, either on paper or with a computer-recording system. Accuracy and efficiency are especially important, since many readings must be entered during a short period of time.

Rodmen. At each side of the crossing a rodman is responsible for one leveling rod. The rod is guyed in place over the bench mark for the duration of the crossing, the rodman ensures that it is plumb and secure at all times. If more than one setup is required between the target station and the control point, the rodman holds a second rod on a turning point. The rodman may be responsible for setting the target(s), and measuring and reporting the target heights, as required.

4.2.3 Equipment

Each side of a river crossing should have a leveling truck and a complete set of geodetic leveling equipment (appendix A). Equipment appropriate to the crossing routine must be available. (See subchapter 4.3 or 4.4.) Even if Zeiss River Crossing Equipment is used, an ordinary leveling instrument and rods should be used to level between the bench mark and the target station.

In addition, two-way radios should be available to permit communication between the two stations. Signal flags may be used if radios are not available. The observers raise the flags to indicate when foresight observations are being made.

When instruments must be interchanged between stations, as for the method employing ordinary instruments, a boat and operator may provide the most efficient service. Other means of transport, which may have to be obtained by contract, include a ferry or helicopter.

4.2.4 Environmental Conditions

Refraction effects are most unpredictable when a large vertical air-temperature difference exists, as is usually the case over water on a sunny, windless day. Shimmer can be extreme, making observations difficult. A crossing should be conducted when refraction effects are apt to be small and uniform—when the sky is overcast and the wind is moderate. Air-temperature differences (sec. 3.6.1, “Measuring air-temperature differences”) may be measured to assist in determining whether conditions are favorable.

Other environmental conditions may interfere with visibility, such as vessel traffic, large swells, wind waves, fog, or having to observe directly into the Sun. Whenever possible, plan the location and time of the crossing to avoid these difficulties.

The leveling unit(s) assigned to a crossing should check each morning to see if conditions are suitable; if not, the units should resume routine leveling. To permit this, the necessary equipment should be available in the leveling trucks when a crossing is assigned.

4.3 Instructions for Zeiss River Crossing Equipment

Because the compensator instruments employed by the National Geodetic Survey have no mechanism for precisely tilting and measuring the tilt of the line of sight, Zeiss River Crossing Equipment is normally used to perform a river crossing. The equipment includes instruments with rotary-wedge attachments that enable the observers to tilt the line of sight by a precisely measured amount.

The equipment has two other versatile features. First, so instruments need not be transported from one side of the crossing to the other, four instruments are employed. Each pair of instruments is placed in reciprocal collimation, enhancing accuracy by limiting the mean collimation error on each side to $\pm 0''.2$.

Second, to permit more flexibility when selecting sites for bench marks, target stations are used. The stations are located close to the shoreline, where in methods using ordinary equipment the marks must be set. As a result, the marks may be set farther away from the shoreline, improving their quality and potential for survival.

4.3.1 Description of Equipment

Two complete sets of Zeiss River Crossing Equipment are necessary, one for each side of the crossing. Each set, labeled “A” or “B,” includes the following:

1. Two Zeiss Ni2 leveling instruments, marked “1” and “2.”
2. Two rotary-wedge attachments for the Ni2 instruments.
3. One base plate for the Ni2 instruments.
4. Two targets.
5. One target column.
6. One tribrach.
7. One tripod, with adjustable legs, for the instrument station.
8. One tripod, for the target station.
9. One auxiliary scale, 0.6 m in length, graduated in units compatible with the ordinary leveling equipment.

Ni2 instrument. The Ni2 is illustrated in figure 3-18 and described in section 3.3.3. Before the river crossing begins, the collimation error of each instrument should be checked. If one of the instruments is to be used for leveling from the nearby target station to the nearby bench mark, a micrometer attachment may be required. If so, the micrometer units should be compatible with the units of the leveling rod used. (See sec. 3.3.4, “Optical micrometer.”)

Rotary-wedge attachment. Each rotary-wedge attachment slips over the objective end of an Ni2. The attachment includes a rotatable optical element, the wedge, to which is attached a graduated scale. To be sufficiently precise, the attachment must be of the best optical quality.

The wedge is a slightly deviating prism, cut in the shape of a circle and mounted to permit rotation about an axis parallel to the line of collimation of the instrument. It functions in the same way as the prism that is used to adjust the collimation error of such instruments as the Zeiss Nil.

The wedge deflects the line of sight by a small angle ($257''$) in a plane perpendicular to the line of intersection, or "edge," of the two main faces. (The "edge" does not physically exist because it is cut away when the prism is cut to a circular shape.) When the wedge is rotated so the "edge" is parallel to the vertical axis of the instrument (fig. 4-6a), the deflection is entirely in the horizontal plane of the instrument, causing no "tilt" in the line of sight.

However, when the wedge is rotated to some other position (fig. 4-6b), the line of sight is deflected vertically as well as horizontally. The vertical deflection, δ , is observed as a tilt of the line of sight and is proportional to the sine of the rotation angle, ω :

$$\sin \delta = \sin 257'' \times \sin \omega.$$

The attachment is designed to permit a maximum rotation angle of $\pm 51'6''$. Thus, the line of sight can be smoothly tilted as much as $200''$ above or below the horizontal plane of the instrument.

Units representing equal increments of sine of the rotation angle are graduated on the attached scale (fig. 4-7), that rotates with the wedge. To avoid difficulty with algebraic signs, the unrotated position (no vertical tilt) is numbered "10", the position of maximum upward tilt is numbered "0", and the position of maximum downward tilt is numbered "20". Each wedge unit is graduated into ten subunits, and each subunit is large enough to permit estimation of tenths of a subunit. Therefore, the angle of tilt can be measured to one hundredth of a unit. Since each unit represents $20''$ (0.0001 radian), the smallest angle that can be measured is $\pm 0''.2$ (0.000001 radian).

The wedge is rotated by turning a knob that is provided with both coarse and fine modes of motion, similar to the focusing knob on the instrument itself. In the coarse mode, which is available for the entire range of rotation, the knob is slightly difficult to turn. Reversing the knob shifts the mode from coarse to fine. The knob remains in the fine mode, where it is much easier to turn, for only 0.5 to 1.0 wedge unit (depending on which part of the scale is in use), after which it reverts to the coarse mode. The line of sight can be directed most precisely with the knob in the fine mode. Therefore, make all final pointings in this manner.

Base plate. The base plate is an elongated metal casting designed to support the pair of instruments. It screws onto the head of an ordinary tripod. On the plate, positions

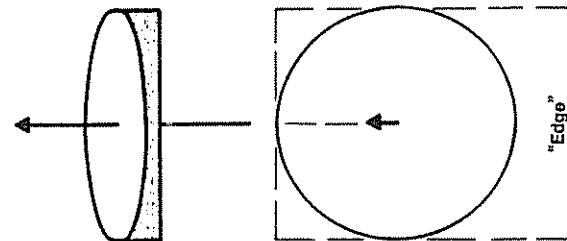

Line of sight not deflected vertically.

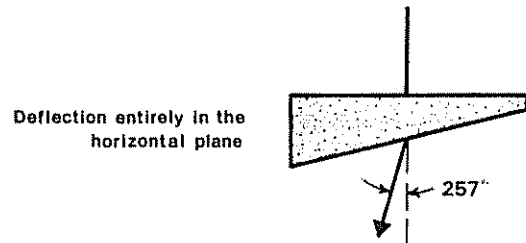

Deflection entirely in the horizontal plane

[a]

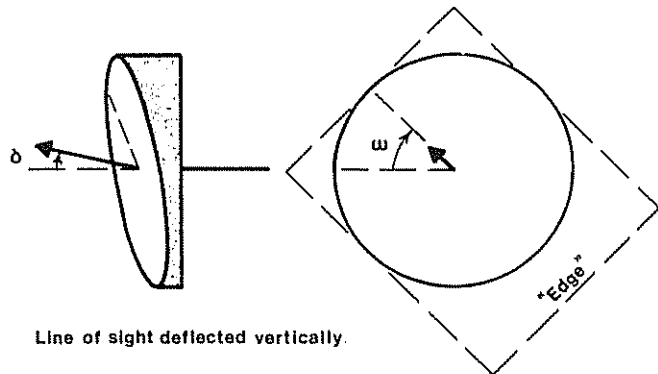

Line of sight deflected vertically.

[b]

Figure 4-6.—Rotary wedge, unrotated (a) and rotated (b).

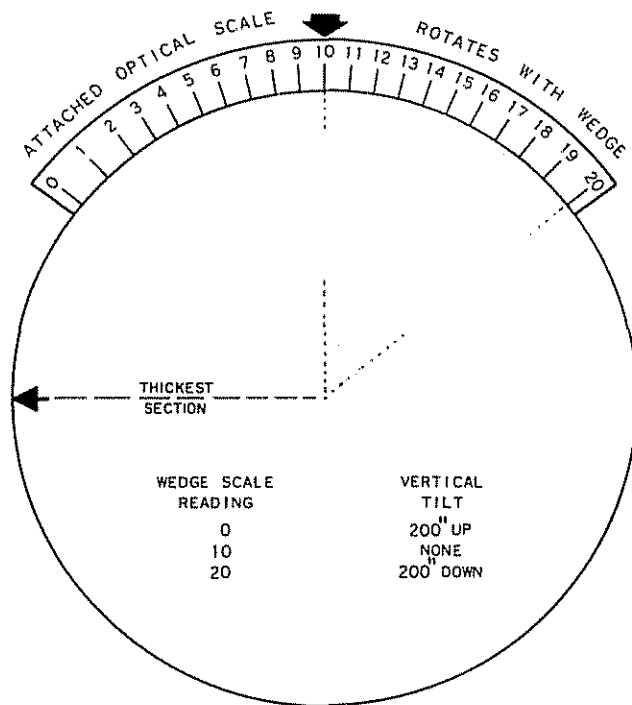

Figure 4-7.—Rotary wedge scale.

for each instrument are labeled and marked with red lines. The attached clamping screws, similar to those found on tripods, are used to secure the instruments.

Tribrach. The tribrach is an ordinary, separate, three-screw, leveling base intended for use with any surveying instrument provided with a matching stub. In this application, it provides the means for mounting and plumbing the target column on a tripod.

Target column. The target column (fig. 4-8) is a piece of channel section, with a stub suitable for mounting it in the tribrach. A circular level at the foot of the column provides a reference for precisely aligning the column with the direction of gravity. On the column are four pairs of precisely spaced studs on which the targets can be mounted.

The height stud is attached horizontally near the base of the column and terminates in a circular knob. The top of the knob is at precisely the same height as the target center defined by the lowest pair of studs. It serves as the control point from which leveling is conducted to the nearby bench mark.

Targets. Two metal targets, each 20 by 30 cm, are provided with each set of equipment. Each target is black, with a white isosceles triangle painted on it. Each target is equipped with a mounting bracket that fits over a pair of studs on the target column. The horizontal centerline of each target can be mounted 0.00, 40.00, 80.00, or 120.00 half-centimeters (hcm) above the height stud (fig. 4-9).

Auxiliary scale. The auxiliary scale is a short, wood-en leveling rod, 0.6 m in length. It is used to level from the height stud on the target column to the nearby bench

mark. When in use, it is held vertically against the target column, with the base resting on the top of the knob of the height stud (fig. 4-10).

The scale is graduated in half-centimeter units. The graduations are grouped and numbered in sets of ten blocks, which alternate black and white, forming a checkerboard pattern. The first ten sets of blocks are numbered from 0 through 9, to be read as tens of rod units (010, 020, 030, etc.). The second four sets of blocks are numbered from 0 through 3, with a large dot over each number to indicate that the readings should be preceded by "1" (100, 110, 120, and 130).

4.3.2 Setups

On each side of the crossing, position an instrument station opposite a target station located on the other side. A correct pair of setups is illustrated in figure 4-11. The foresights, from each instrument to the opposite target station, must be as similar in length as possible, within 1 m in height and adjacent within 3 m.

Instrument station. Set up the instrument station as follows:

1. Set the adjustable-leg tripod firmly in the ground. It must not move during the entire running.
2. Orient the base plate on the tripod so the long axis is perpendicular to the line of sight to the opposite target station, with the indicated position for instrument 1 on the left.

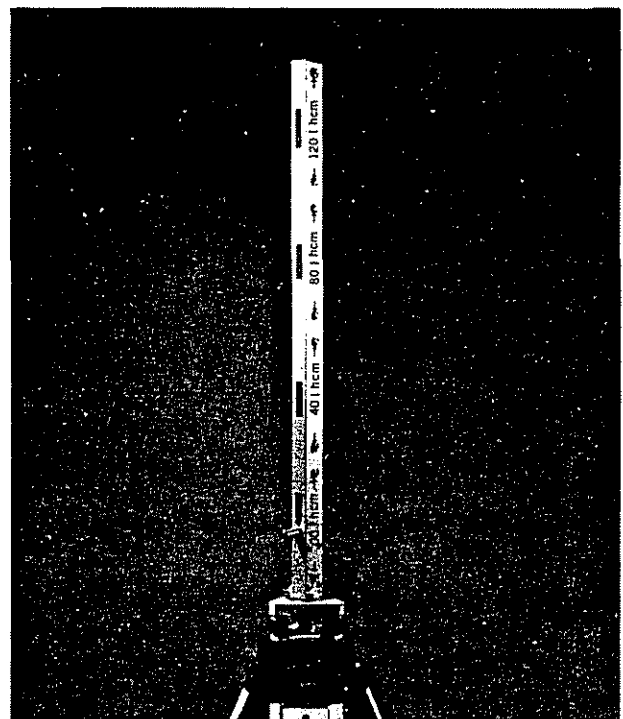

Figure 4-8.—Target column.

3. Level the base plate roughly by centering the bubble in the circular level. There are no foot screws or similar devices on the base plate; therefore, level it by varying the lengths of the tripod legs or by changing the positions of the tripod feet in the ground. This ensures that the lines of sight of the two instruments will be at nearly the same elevation.

4. Secure the rotary-wedge attachments to the instruments.

5. Attach the instruments to the base plate in the indicated positions, aligning the red marks on the instrument tribrachs with the numbered, red marks on the base plate (fig 4-12). In this way, one foot screw of each instrument is positioned in line with the long axis of the base plate and the other two are aligned perpendicularly to it.

6. Set the three foot screws on each instrument to the middle position of their range of movement. The top edge of each screw should be even with the indexing ring marked on the dust skirt. This procedure limits the elevation difference between the two instruments. Make all subsequent leveling adjustments by using only the screws aligned perpendicularly to the long axis of the base plate. Do not use the screws that are aligned with the long axis again during the entire running.

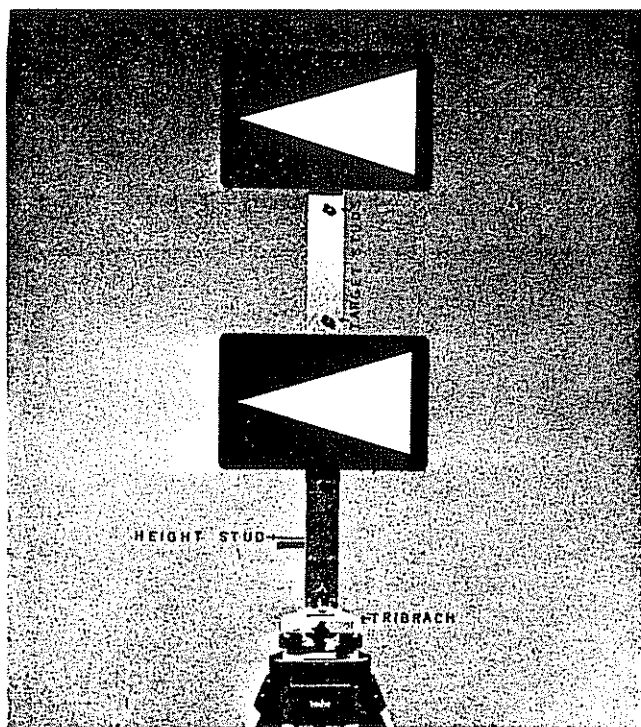

Figure 4-9.—Targets mounted on target column.

Target station. Set up the target station as follows:

1. Attach the target column to the tribrach and mount it on the tripod (fig. 4-9). It must not move during the entire running.

2. Secure two targets to the target column. Position them at the same heights on each side of the crossing, placing the lower target at zero, if possible.

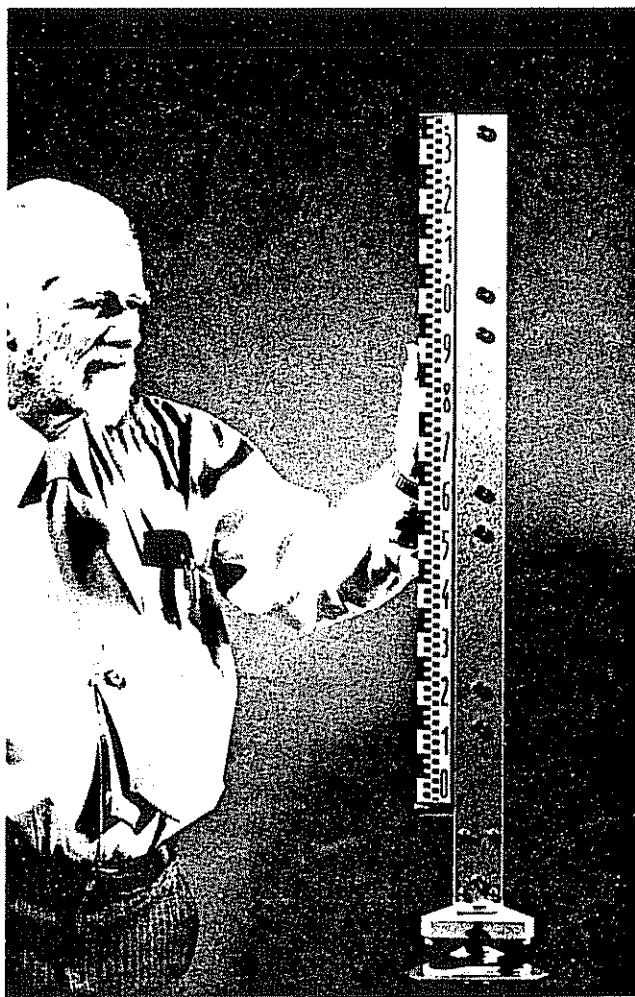

Figure 4-10.—Using the auxiliary scale.

3. One target must be above, and one below, the mean line of sight from the opposite instrument pair. The angle of tilt from the lower target to the upper target should be five wedge units or more. Consult with the observer on the opposite side to ensure that these conditions are satisfied. Adjust the height of the tripod or targets as necessary.

4. Plumb the target column by centering the bubble in the circular level, using the three leveling screws on the tribrach.

Leveling rod. Set a geodetic leveling rod on the nearby bench mark. To preserve the usual value for the rod constant difference when leveling from the nearby target station to the mark with only one setup, use rod 2 of the standard pair. If two setups are necessary, use rod 1. During the series of observations from the bench mark to the opposite target station, the rod constant is not important because only the low scale is observed.

Plumb and guy the rod in place with three wires attached at the top center. Rotate the rod to face the nearby instrument station.

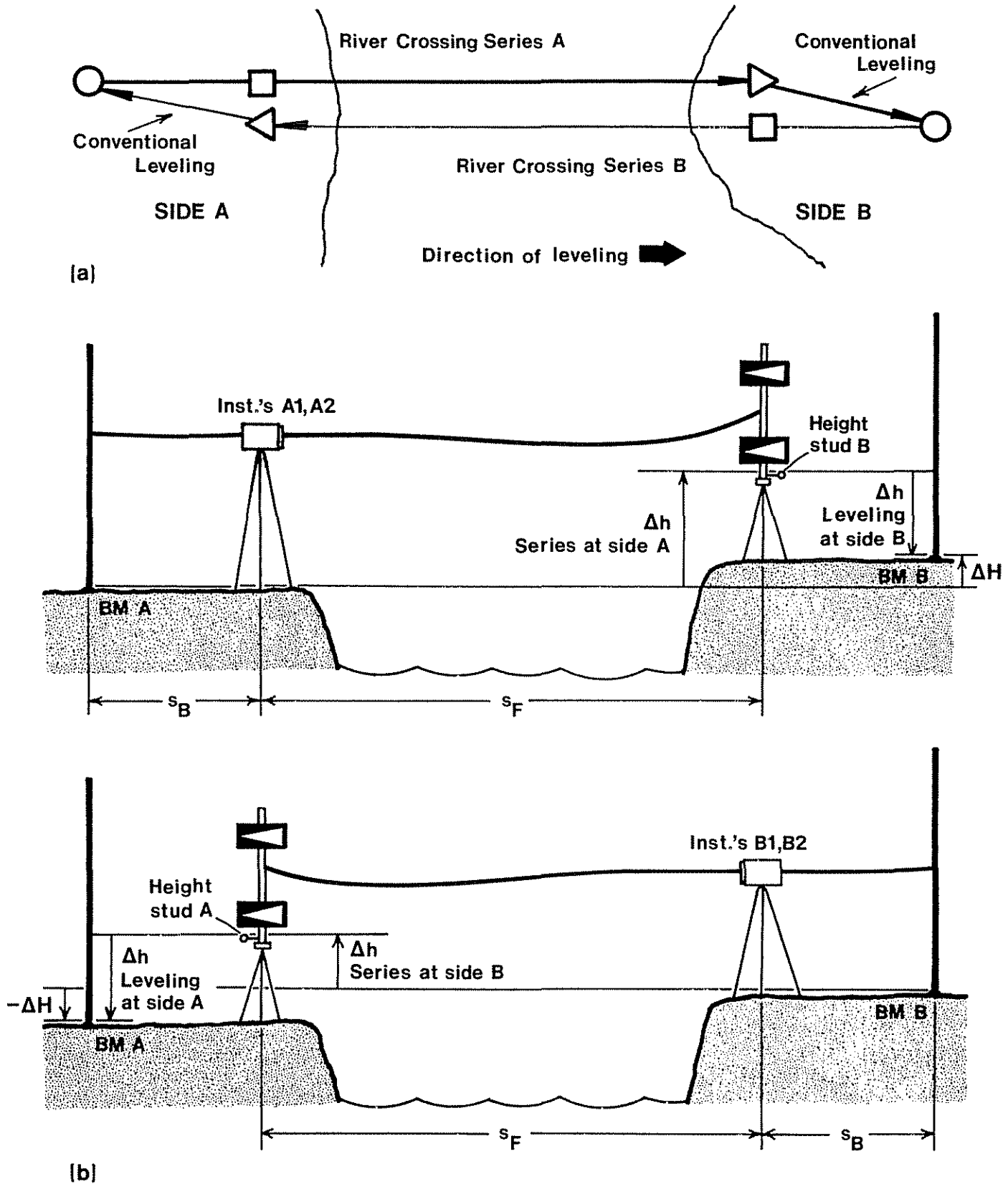

Figure 4-11.—Setups for Zeiss River Crossing Equipment, top view (a) and side view (b).

$$\Delta h = \frac{1}{2}[(\Delta h_{\text{Series A}} + \Delta h_{\text{Leveling B}}) - (\Delta h_{\text{Series B}} + \Delta h_{\text{Leveling A}})]$$

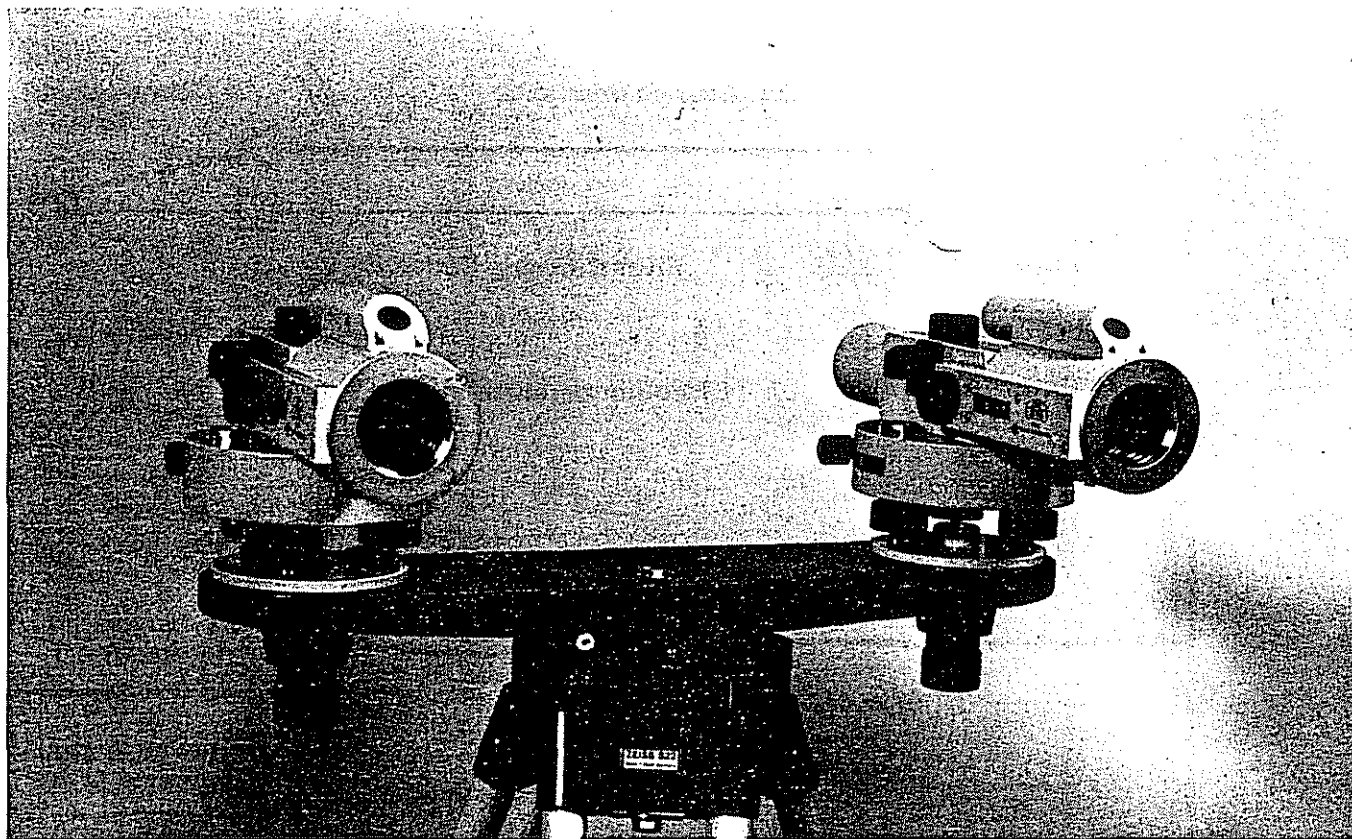

Figure 4-12.—Instruments mounted on base plate.

4.3.3 Observing Routine

One running of the observing routine includes, on each side, the measurement of two elevation differences. The first is obtained by conventional leveling from the nearby target station to the nearby bench mark. The second is obtained by a series of observations from the nearby bench mark to the opposite target station. The first is then measured again to ensure that the nearby target station has not moved. To compute the total elevation difference from the nearby bench mark to the opposite bench mark, the result of the series of observations from one side is added to the result of the conventional leveling from the opposite side. The total computed at one side is meaned with the total computed at the other side to obtain the elevation difference for the running. (See fig. 4-11.)

For a complete river crossing, two runnings are required that close as described in section 3.7.7. If both runnings cannot be completed in one day, the second running may be conducted another day. (See table 4-1 for a summary of the observing routine.)

If possible, record the observations on a computer, using backup forms if necessary. The instructions that follow include procedures for using the standard recording forms.

Collimation checks. On each side of the crossing, check the collimation errors of the pair of Ni2 instruments, following a procedure described in section 3.3.7. Since the instruments are to be set in reciprocal collimation, adjustment is not necessary unless the difference in collimation errors exceeds 40" ($C_1 - C_2 > 0.20$ mm/m).

Perform a collimation check with the instrument to be used for the nearby leveling. One Ni2 may be removed from the base plate of the instrument station and used for this purpose. Adjust the instrument if it does not satisfy the tolerance for the order and class of the survey (table 3-1).

Leveling, nearby target station to nearby bench mark. On each side of the crossing, double run a section of leveling from the height stud of the nearby target station to the nearby bench mark. Follow the usual observing routine, satisfying specifications for the order and class of the survey and preparing a survey equipment record (i.e., line *40*) and beginning and ending running records (i.e., line *41*) (Pfeifer and Morrison 1980: vol. II.)

The auxiliary scale must be used on the height stud. Make sure the units of the scale are compatible with the leveling equipment; convert the scale readings to appropriate rod units, if necessary. If employing the micrometer leveling procedure, described in section 3.7.2, a special computation is necessary to obtain a

high-scale reading. Read the scale in the same manner as for the low-scale reading. Then, add the rod constant of rod 1 to the reading before recording it. (See fig. 4-13 for an example.)

Series, nearby bench mark to opposite target station. On each side of the crossing, make a series of observations to determine the elevation difference from the nearby bench mark to the height stud of the opposite target station. This series follows the pattern backsight-foresight-backsight. The backsights each include one set of observations to “lower” and “upper” graduations on the leveling rod placed on the bench mark. The foresight includes four sets of observations to the lower and upper targets on the opposite side. Every set includes observations from both instruments at the station. Do not interrupt a series once it has started.

1. Prepare the beginning series record (line *42*). Include the following information: date, the instrument codes and serial numbers, the rod code and serial number, the survey-point serial number and stamping of the bench mark (or designation if no stamping), the survey-

point serial number and designation of the opposite height stud, the running number, the local time zone and time, the temperature units and temperature, the wind code, the sun code, and the initials of the observer, recorder, and rodman (Refer to the annotated recording form shown in fig. 4-14. An example is given in fig. 4-15.)

2. Record the positions of the nearby targets as indicated on the form. Communicate this information to the recorder on the opposite side.

3. Obtain the positions, T and t , of the targets on the opposite side. Enter the positions as indicated on the recording form, in units identical to those of the leveling rod. For example, with a half-centimeter rod, enter 0, 40, 80, or 120 hcm for each target. Compute the difference, D , between the target positions.

4. At the instrument station, turn both instruments to point away from the target station on the opposite side. This procedure is indicated on the recording form as “↓”. Carefully center the bubble in each circular level, using only the foot screws aligned perpendicularly to the long axis of the base plate.

5. **RECIPROCAL COLLIMATION:** Perform a reciprocal collimation immediately before every set of observations in the series, as follows:

a. Looking through instrument 1, focus precisely on a distant, sharply defined object. Then, turn the instruments toward each other. Looking through instrument 2, focus instrument 2 until the reticle lines of instrument 1 are sharply defined (fig. 4-16a). This procedure focuses both instruments at infinity.

b. Rotate the wedge knob on instrument 1 until the scale is set at 10.00. Make the final setting with the knob in fine mode. (See sec. 4.3.1, “Rotary-wedge attachment.”)

c. Looking through instrument 2, rotate the wedge knob to bring the middle reticle line into coincidence with the image of the middle line of instrument 1 (fig. 4-16b). Make the final setting by turning the knob clockwise, in fine mode. Record the reading of the wedge scale.

d. With the knob still in fine mode, move the middle line of instrument 2 out of coincidence by a small amount and set it again. This time make the final setting by turning the knob counterclockwise. Record the second scale reading. Compute the mean, r , of the two readings.

6. **BACKSIGHT:** Turn the instruments to point at the leveling rod placed on the nearby bench mark. First, with instrument 1 and then with instrument 2 obtain a set of observations by carefully following the instructions here. With each instrument, intercept the same lower and upper graduations on the low scale. Make all final settings with the wedge knob in fine mode.

a. Refocus the instrument to obtain a sharp image of the rod scale.

b. Set the wedge scale to 20.0 by turning the wedge knob clockwise (the scale moves counterclockwise). The setting need not be precise.

Table 4-1.—Summary of crossing routine for Zeiss River Crossing Equipment

| | | | |
|---|-------------|---------------------|-------------|
| During each running, on both side A and side B: | | | |
| Set up instrument station, target station, and leveling rod | | | |
| Make COLLIMATION CHECKS with the leveling instruments. | | | |
| Double run a section of LEVELING from the nearby target station to the nearby bench mark. | | | |
| Observe a SERIES, simultaneously with the opposite side: | | | |
| 1. Point away from the opposite target station and level the instruments | | | |
| 2. Observe and record reciprocal collimation. | | | |
| 3. Observe and record backsights to nearby leveling rod | | | |
| 4. Point toward the opposite target station and level the instruments | | | |
| 5. Observe and record reciprocal collimation. | | | |
| 6. Observe and record foresights to opposite target station. | | | |
| 7. Point away - reciprocal collimation - foresight observations | | | |
| 8. Point toward - reciprocal collimation - foresight observations | | | |
| 9. Point away - reciprocal collimation - foresight observations | | | |
| 10. Point toward - reciprocal collimation - backsight observations | | | |
| Double run a section of LEVELING from the nearby target station to the nearby bench mark. | | | |
| During one day: | | OR During two days: | |
| COLLIMATION CHECKS | } RUNNING 1 | COLLIMATION CHECKS | } RUNNING 1 |
| LEVELING SERIES | | LEVELING SERIES | |
| | | LEVELING | |
| LEVELING SERIES | } RUNNING 2 | COLLIMATION CHECKS | } RUNNING 2 |
| LEVELING | | LEVELING SERIES | |
| | | LEVELING | |

RIVER CROSSING SERIES, SIDE A or B

| | | | | | | | | | | | | | | | | | | | | | | | | | | | | | | | | | | | |
|---|--|-----|--|-------------|--|------|--|-----------------------|--|------|--|---|--|------|--|----------------|--|-----------------------------|--|---------|--|------------|--|---|--|--|--|--|--|--|--|--|--|--|--|
| | | | | | | | | | | | | PAGE | | | | | | | | | | | | | | | | | | | | | | | |
| | | | | | | | | | | | | OF | | | | | | | | | | | | | | | | | | | | | | | |
| YR. | | MO. | | DAY | | CODE | | INSTRUMENT SERIAL NO. | | CODE | | INSTRUMENT SERIAL NO. | | CODE | | ROD SERIAL NO. | | TARGET POSITIONS, THIS SIDE | | RUN NO. | | | | | | | | | | | | | | | |
| | | | | | | | | | | | | | | | | | | TOP | | BOTTOM | | | | | | | | | | | | | | | |
| FROM | | | | DESIGNATION | | | | TO | | | | DESIGNATION | | | | TIME | | TEMPERATURE | | W. S. | | OB. SERVER | | | | | | | | | | | | | |
| | | | | | | | | | | | | BEGIN | | END | | BEGIN | | END | | | | | | | | | | | | | | | | | |
| INSTRUMENT No. 1 | | | | | | | | | | | | INSTRUMENT No. 2 | | | | | | | | | | | | COMPUTATIONS | | | | | | | | | | | |
| ↓ RECIPROCAL COLLIMATION | | | | | | | | | | | | ↓ RECIPROCAL COLLIMATION | | | | | | | | | | | | GRADUATIONS: $G - G = d$ | | | | | | | | | | | |
| LOWER G (1) (2) l_1 | | | | | | | | | | | | LOWER G (1) (2) l_2 | | | | | | | | | | | | $l_1 - 10$ $l_1 - u_1$ l_1 I_{START} + I_{MEAN} | | | | | | | | | | | |
| UPPER g (1) (2) u_1 | | | | | | | | | | | | UPPER g (1) (2) u_2 | | | | | | | | | | | | $l_2 - r$ $l_2 - u_2$ l_2 S_{START} Backsight | | | | | | | | | | | |
| ↑ RECIPROCAL COLLIMATION | | | | | | | | | | | | ↑ RECIPROCAL COLLIMATION | | | | | | | | | | | | TARGETS OPPOSITE: $I - T = D$ | | | | | | | | | | | |
| (1) (2) (3) (4) (5) (6) (7) (8) (9) (10) b_1 | | | | | | | | | | | | (1) (2) (3) (4) (5) (6) (7) (8) (9) (10) b_2 | | | | | | | | | | | | $b_1 - 10$ $b_1 - u_1$ H_1 S_1 + H_{MEAN} | | | | | | | | | | | |
| 10.00 B_1 | | | | | | | | | | | | 10.00 B_2 | | | | | | | | | | | | Fore-sight | | | | | | | | | | | |
| ↓ RECIPROCAL COLLIMATION | | | | | | | | | | | | ↓ RECIPROCAL COLLIMATION | | | | | | | | | | | | Backsight | | | | | | | | | | | |
| (10 WEDGE SCALE SETTINGS LOWER TARGET INSTR. 1) | | | | | | | | | | | | (10 WEDGE SCALE SETTINGS LOWER TARGET INSTR. 2) | | | | | | | | | | | | -Fore-sight | | | | | | | | | | | |
| 10.00 | | | | | | | | | | | | 10.00 | | | | | | | | | | | | Conversion | | | | | | | | | | | |
| ↑ RECIPROCAL COLLIMATION | | | | | | | | | | | | ↑ RECIPROCAL COLLIMATION | | | | | | | | | | | | Δh (rod units) | | | | | | | | | | | |
| 10.00 | | | | | | | | | | | | 10.00 | | | | | | | | | | | | Δh | | | | | | | | | | | |
| ↓ RECIPROCAL COLLIMATION | | | | | | | | | | | | ↓ RECIPROCAL COLLIMATION | | | | | | | | | | | | s_B | | | | | | | | | | | |
| 10.00 | | | | | | | | | | | | 10.00 | | | | | | | | | | | | + s_B | | | | | | | | | | | |
| ↑ RECIPROCAL COLLIMATION | | | | | | | | | | | | ↑ RECIPROCAL COLLIMATION | | | | | | | | | | | | S | | | | | | | | | | | |
| LOWER | | | | | | | | | | | | LOWER | | | | | | | | | | | | I_{END} | | | | | | | | | | | |
| UPPER | | | | | | | | | | | | UPPER | | | | | | | | | | | | S_{END} | | | | | | | | | | | |
| REMARKS | | | | | | | | | | | | | | | | | | | | | | | | | | | | | | | | | | | |

Figure 4-14.—Annotated recording form for the series of observations from the nearby bench mark to the opposite target station.

e. Compute the mean backsight interval, I :

$$I = (i_1 + i_2) / 2.$$

f. Compute the backsight distance, s_B , in meters. First compute the mean of $l_1 - u_1$ and $l_2 - u_2$. Then,

$$s_B = [d_{rod\ units} \times \text{conversion factor}_{m/rod\ unit}] / [(l - u)_{mean} \times 0.0001_{radian/wedge\ unit}]$$

For d in half-centimeter units:

$$s_B = (50 \times d) / [(l - u)_{mean}]$$

For d in centimeter units:

$$s_B = (100 \times d) / [(l - u)_{mean}]$$

8. Turn both instruments toward (“”) or away from (“”) the opposite target station, as indicated on the recording form. On each instrument, displace the bubble in the circular level toward the station. Then, carefully recenter it.

9. Repeat the reciprocal collimation, step 5.

10. FORESIGHT: Before beginning each set of target observations, coordinate the activities with the observing team on the opposite side, using radios or visual signals. The two observing teams must begin each set simultaneously. For each set, carefully follow the instructions given here, first with instrument 1. Then, repeat the procedure with instrument 2. Make all final settings with the wedge knob in fine mode.

a. Point the instrument at the opposite target station and observe the lower target. Turn the wedge knob clockwise until the middle reticle line appears slightly below the lower target. If the middle line is already below the lower target, move it to a position substantially above the target before starting.

b. Reverse the knob and, in fine mode, intercept the target. Record the scale reading.

c. Continue turning the knob (counterclockwise) until the middle line appears slightly above the target. The knob should remain in fine mode. Release your fingers and grasp the knob in another place. Reverse it and, in fine mode, intercept the target. Record the scale reading.

d. Repeat steps 10a through 10c until ten settings (five counterclockwise and five clockwise) have been made on the lower target. Compute the mean, b .

e. Observe the upper target Turn the wedge knob counterclockwise until the middle reticle line appears slightly above the upper target.

f. Reverse the knob and, in fine mode, intercept the upper target. Record the scale reading.

g. Continue turning the knob (clockwise) until the middle line appears slightly below the target. Release your fingers and grasp the knob in another place. Reverse it and, in fine mode, intercept the target. Record the scale reading.

h. Repeat steps 10e through 10g until ten settings (five clockwise and five counterclockwise) have been made on the upper target. Compute the mean, *a*.

11. Repeat steps 8 through 10 to obtain a total of four sets of target observations. In step 8, prior to successive sets, point the instruments alternately toward ("I") and away ("J") from the opposite target station. The correct positions are indicated, as a reminder, on the recording form (fig. 4-14). Regardless of the direction in which the instruments are pointed, always displace the bubbles toward the opposite target station.

12. This step may be performed after all the crossing observations are completed. Compute the mean foresight interval, *H*, for each set as follows (fig. 4-18):

a. Compute the mean value for the reciprocal collimation of Instrument 2 from the values observed before and after each set:

$$r_{\text{mean}} = (r_{\text{before}} + r_{\text{after}}) / 2$$

b. Compute the angles of tilt from the settings on the lower target to the collimated lines of sight: $b_1 - 10$, for instrument 1; and $b_2 - r$, for instrument 2.

c. For each instrument, compute the angle of tilt from the lower target to the upper target:

$$b_1 - a_1 \text{ and } b_2 - a_2$$

d. For each instrument, compute the distance, *h*, from the lower target to the intercept of the mean line of sight, in rod units. Recall that *D* is the difference in the position of the opposite targets, *t* - *T*:

$$h_1 = [D \times (b_1 - 10)] / (b_1 - a_1),$$

$$h_2 = [D \times (b_2 - r)] / (b_2 - a_2).$$

e. Compute the mean foresight interval, *H*:

$$H = (h_1 + h_2) / 2.$$

| RIVER CROSSING SERIES, SIDE <u>A</u> EXAMPLE | | | | | | | | | | | | FILE | | | |
|--|-------------|------|------|------------------------|---------------|-----------------------|-------|---------------------------------|-----------------------------|--------|-----------|-------|-------|-------|--------------|
| | | | | | | | | | | | 3 of 7 | | | | |
| YR. | MO. | DAY | CODE | INSTRUMENT SERIAL NO. | CODE | INSTRUMENT SERIAL NO. | CODE | ROD SERIAL NO. | TARGET POSITIONS, THIS SIDE | | RUN NO. | | | | |
| 8 | 0 | 7 | 08 | 1725385 | 232 | 1725760 | 316 | 241603 | TOP | BOTTOM | | | | | |
| FROM | DESIGNATION | | | TO | DESIGNATION | | | TIME | TEMPERATURE | WIND | BAROMETER | | | | |
| 01/33 | CAISSON USE | | | 0002 | HEIGHT STUD B | | | 1000/1205 | 7.5 | 8.1 | 12 | | | | |
| INSTRUMENT No. 1 | | | | INSTRUMENT No. 2 | | | | COMPUTATIONS | | | | | | | |
| RECIPROCAL COLLIMATION | | | | RECIPROCAL COLLIMATION | | | | GRADUATIONS: 102 - 97 = 5 | | | | | | | |
| ROD | LOWER | 097 | 1696 | 1700 | 16.98 | LOWER | 097 | 1572 | 1574 | 15.73 | 6.98 | 12.92 | 2.70 | 2.32 | + 2.33 |
| ROD | UPPER | 102 | 0405 | 0408 | 04.06 | UPPER | 102 | 0224 | 0225 | 02.24 | 5.27 | 13.49 | 1.95 | 18.9 | 99.33 hcm |
| RECIPROCAL COLLIMATION | | | | RECIPROCAL COLLIMATION | | | | TARGETS OPPOSITE: 120 - 0 = 120 | | | | | | | |
| 1 | 1710 | 1711 | 1712 | 1713 | 1715 | 16.00 | 1598 | 1594 | 1591 | 1596 | 7.12 | 97.76 | | | + 84.83 |
| 1 | 1711 | 1710 | 1710 | 1713 | 1715 | 10.00 | 16.02 | 1595 | 1595 | 1592 | 10.58 | 8.74 | 85.06 | 678.7 | 84.83 hcm |
| 1 | 0831 | 0841 | 0830 | 0835 | 0840 | 07.05 | 0707 | 0700 | 0701 | 0699 | 5.39 | 72.35 | | | 99.33 |
| 1 | 0840 | 0850 | 0832 | 0838 | 0842 | 07.06 | 0708 | 0700 | 0700 | 0698 | 07.03 | 8.94 | | | - 84.83 |
| RECIPROCAL COLLIMATION | | | | RECIPROCAL COLLIMATION | | | | GRADUATIONS: 1055 - 1058 = 3 | | | | | | | |
| 2 | 1719 | 1709 | 1705 | 1705 | 1702 | 15.85 | 1589 | 1597 | 1591 | 1584 | 7.07 | 97.74 | | | 14.50 hcm |
| 2 | 1710 | 1709 | 1702 | 1706 | 1702 | 10.00 | 15.88 | 1590 | 1592 | 1586 | 10.63 | 8.68 | 84.26 | 682.6 | + 2.00 hcm/m |
| 2 | 0139 | 0142 | 0142 | 0141 | 0136 | 07.00 | 0702 | 0698 | 0698 | 0698 | 06.98 | 5.25 | 70.79 | | + 0.07180 m |
| 2 | 0140 | 0140 | 0140 | 0133 | 0132 | 06.99 | 0701 | 0695 | 0699 | 0695 | 8.90 | | | | |
| RECIPROCAL COLLIMATION | | | | RECIPROCAL COLLIMATION | | | | GRADUATIONS: 1070 - 1071 = 1 | | | | | | | |
| 3 | 1718 | 1715 | 1707 | 1703 | 1702 | 15.85 | 1591 | 1587 | 1591 | 1590 | 7.09 | 97.91 | | | 19.0m |
| 3 | 1719 | 1710 | 1708 | 1702 | 1703 | 10.00 | 15.90 | 1589 | 1589 | 1585 | 10.62 | 8.69 | 94.54 | 683.4 | + 674.0m |
| 3 | 0840 | 0840 | 0840 | 0842 | 0838 | 07.00 | 0698 | 0699 | 0702 | 0707 | 07.01 | 5.26 | 71.16 | | 703.0m |
| 3 | 0842 | 0839 | 0843 | 0835 | 0838 | 06.99 | 0695 | 0701 | 0700 | 0703 | 8.87 | | | | |
| RECIPROCAL COLLIMATION | | | | RECIPROCAL COLLIMATION | | | | GRADUATIONS: 1053 - 1055 = 2 | | | | | | | |
| 4 | 1715 | 1712 | 1712 | 1711 | 1709 | 15.76 | 1579 | 1580 | 1580 | 1575 | 7.11 | 98.75 | | | |
| 4 | 1710 | 1715 | 1717 | 1709 | 1707 | 10.00 | 16.79 | 1577 | 1579 | 1578 | 10.52 | 8.64 | 95.46 | 691.2 | |
| 4 | 0150 | 0145 | 0149 | 0145 | 0146 | 07.05 | 0702 | 0703 | 0707 | 0701 | 5.25 | 72.16 | | | |
| 4 | 0145 | 0151 | 0149 | 0145 | 0145 | 07.04 | 0703 | 0708 | 0706 | 0702 | 8.73 | | | | |
| RECIPROCAL COLLIMATION | | | | RECIPROCAL COLLIMATION | | | | GRADUATIONS: 1050 - 1050 = 0 | | | | | | | |
| BACKSIGHT | LOWER | 097 | 1700 | 1702 | 17.01 | LOWER | 097 | 1580 | 1580 | 15.80 | 7.01 | 12.92 | 2.71 | 2.34 | |
| BACKSIGHT | UPPER | 102 | 0408 | 0410 | 04.09 | UPPER | 102 | 0242 | 0243 | 02.42 | 5.30 | 13.38 | 1.98 | 19.0 | |

Figure 4-15.—Series from the nearby bench mark to the opposite target.

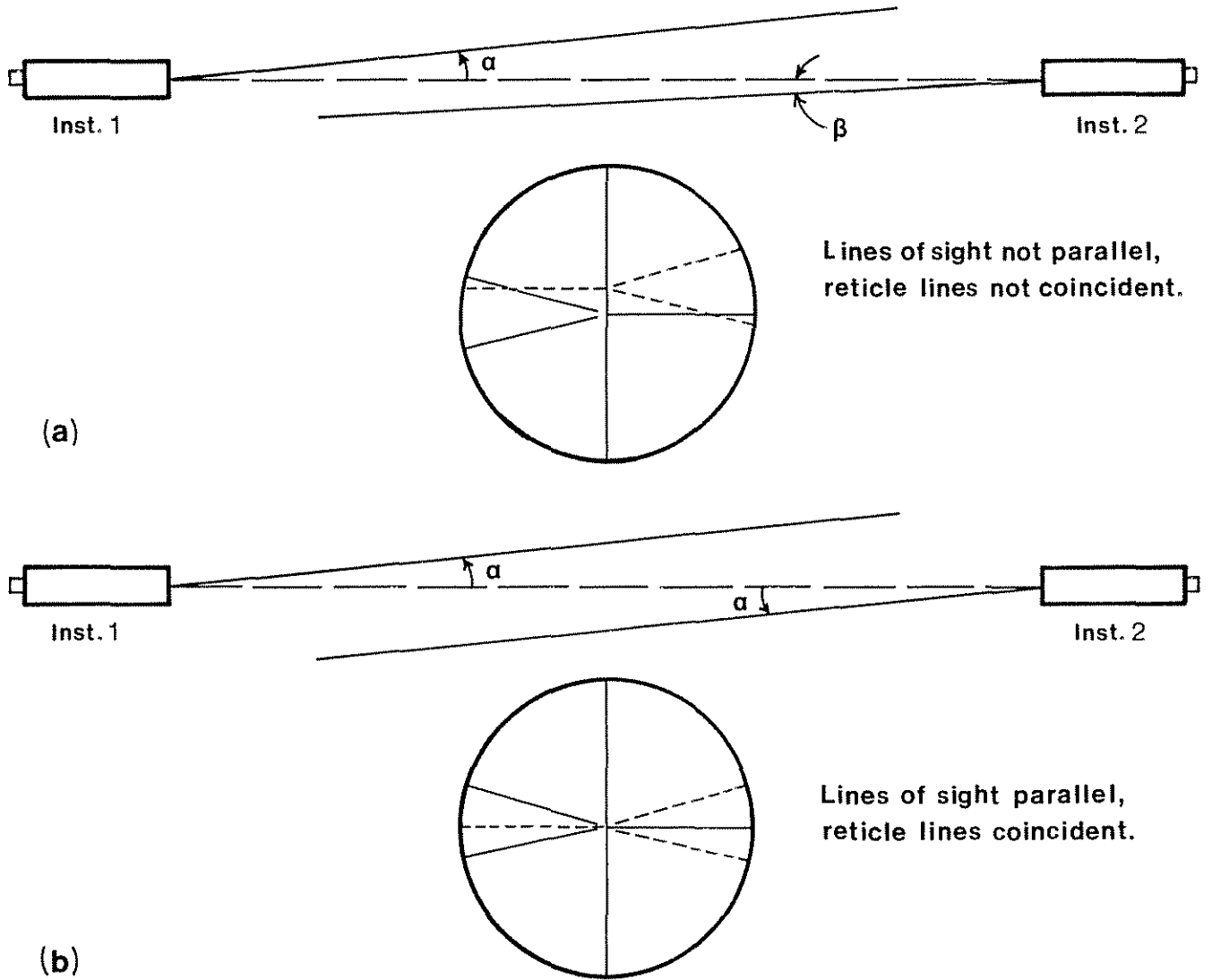

Figure 4-16.—Reciprocal collimation, before (a) and after (b).

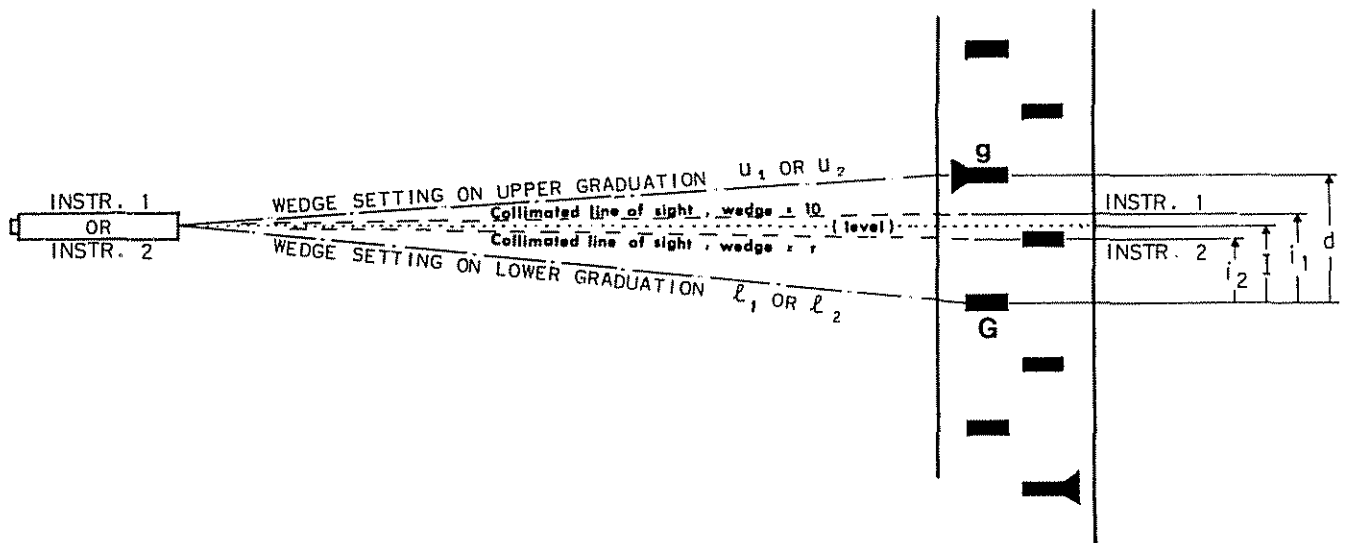

Figure 4-17.—Backsight, wedge settings on rod graduations.

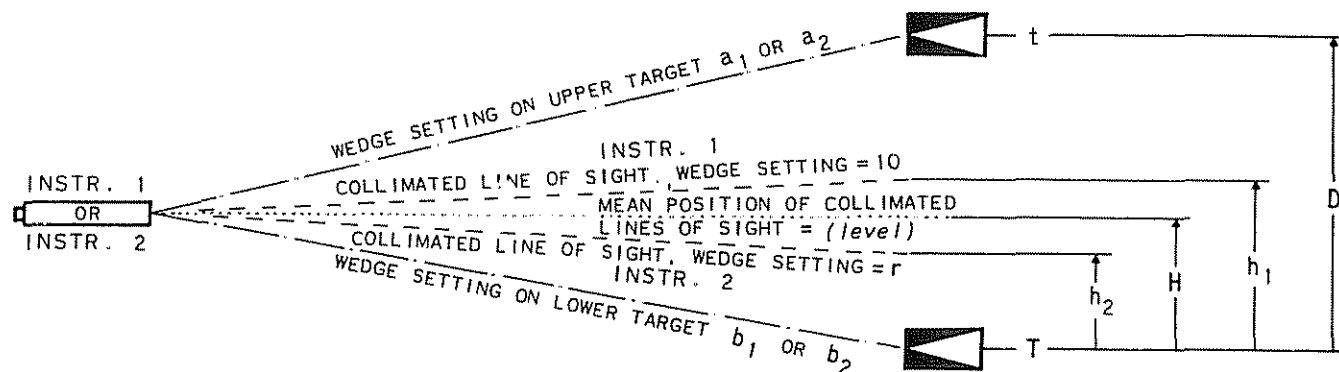

Figure 4-18.—Foresight, wedge settings on targets.

f. Compute the foresight distance, s_F , in meters. First compute the mean of $b_1 - a_1$ and $b_2 - a_2$. Then,

$$s_F = (d_{\text{rod units}} \times \text{conversion factor}_{\text{m/rod unit}}) / [(b-a)_{\text{mean}} \times 0.0001 \text{ radian/wedge unit}]$$

For D in half-centimeter units:

$$s_F = (50 \times D) / [(b-a)_{\text{mean}}]$$

For D in centimeter units:

$$s_F = (100 \times D) / [(b-a)_{\text{mean}}]$$

13. Repeat step 4, with the instruments pointed toward ("↑") the target station. Follow this with a reciprocal collimation, step 5.

14. **BACKSIGHT:** Conclude the observations of the series by repeating a set of observations to the leveling rod, steps 6 and 7. Intercept the same graduations used for the first set. If this is not possible, the instrument station has moved and the series must be started over.

15. Prepare the ending series record (line *42*). Include the time, temperature, wind code, and sun code.

16. This step can be performed after all the crossing observations are completed. Compute the elevation difference for the series, as follows:

a. Compute the backsight intercept, in rod units:

$$\text{Backsight} = G + (I_{\text{start}} + I_{\text{end}}) / 2$$

b. Compute the foresight intercept, in rod units:

$$\text{Foresight} = T + (H_1 + H_2 + H_3 + H_4) / 4$$

c. Compute the elevation difference, Δh , for the series, in meters. For half-centimeter rod units:

$$\Delta h = (\text{Backsight} - \text{Foresight}) / 200$$

For centimeter rod units:

$$\Delta h = (\text{Backsight} - \text{Foresight}) / 100$$

d. Compute the backsight distance, s_B , in meters:

$$s_B = (S_{\text{start}} + S_{\text{end}}) / 2$$

e. Compute the foresight distance, s_F , in meters:

$$s_F = (S_1 + S_2 + S_3 + S_4) / 4$$

f. Compute the total distance for the series: $s_B + s_F$.

Leveling, nearby target station to nearby bench mark. As before (sec. 4.4.3), double run the section from the height stud of the nearby target station to the nearby bench mark. Check for closure with the previous leveling.

4.3.4 Final Computations

If time permits and if data are recorded on a computer, make the final computations for each running while at the crossing site. In any case, all observation records should be submitted to the project office at the end of the day's work.

Each completed crossing should include the records listed in table 4-2. Compute the elevation difference on a cover sheet for each running, as follows (fig 4-19):

1. From the leveling data for side B, enter the elevation differences, Δh , and distances, S , observed from the height stud of the nearby target station to the nearby bench mark. Use the data from the two sections leveled before and the two sections leveled after the series. Mean the elevation differences.

2. From the series data for side A, enter the elevation difference, Δh , and distance, S , observed from the nearby bench mark to the height stud on the opposite target station.

3. Add the leveling results from side B to the series results from side A. The values obtained are the observed elevation difference, Δh_A , and the distance, S_A , from bench mark A to bench mark B.

4. Repeat steps 1 through 3 with the leveling results from side A and the series results from side B. The values obtained are the observed elevation difference, Δh_B , and the distance, S_B , from bench mark B to bench mark A. Do not expect Δh_B to agree with Δh_A , since neither has been corrected for curvature or refraction.

Table 4-2.—Data set for a complete crossing with Zeiss River Crossing Equipment

| | Running record | Section | Form |
|---|--|---------------------------------|-----------------------|
| 1 | River crossing record | BM A to BM B, forward | Cover sheet |
| | Side A | | |
| | Survey equipment record (line *40*) | Collimation checks | NOAA 76-191 or 76-189 |
| | Beginning and ending running records (line *41*) | Height stud A to BM A, forward | NOAA 76-191 or 76-189 |
| | Beginning and ending running records (line *41*) | Height stud A to BM A, backward | NOAA 76-191 or 76-189 |
| | Series records (line *42*) | BM A to height stud B | River crossing series |
| | Beginning and ending running records (line *41*) | Height stud A to BM A, forward | NOAA 76-191 or 76-189 |
| | Beginning and ending running records (line *41*) | Height stud A to BM A, backward | NOAA 76-191 or 76-189 |
| | Side B | | |
| | Survey equipment record (line *40*) | Collimation checks | NOAA 76-191 or 76-189 |
| | Beginning and ending running records (line *41*) | Height stud B to BM B, forward | NOAA 76-191 or 76-189 |
| | Beginning and ending running records (line *41*) | Height stud B to BM B, backward | NOAA 76-191 or 76-189 |
| | Series records (line *42*) | BM B to height stud A | River crossing series |
| | Beginning and ending running records (line *41*) | Height stud B to BM B, forward | NOAA 76-191 or 76-189 |
| | Beginning and ending running records (line *41*) | Height stud B to BM B, backward | NOAA 76-191 or 76-189 |
| 2 | River crossing record | BM A to BM B, forward | Cover sheet |
| | Side A | | |
| | Series records (line *42*) | BM A to height stud B | River crossing series |
| | Beginning and ending running records (line *41*) | Height stud A to BM A, forward | NOAA 76-191 or 76-189 |
| | Beginning and ending running records (line *41*) | Height stud A to BM A, backward | NOAA 76-191 or 76-189 |
| | Side B | | |
| | Series records (line *42*) | BM B to height stud A | River crossing series |
| | Beginning and ending running records (line *41*) | Height stud B to BM B, forward | NOAA 76-191 or 76-189 |
| | Beginning and ending running records (line *41*) | Height stud B to BM B, backward | NOAA 76-191 or 76-189 |

If runs are conducted on separate days, the data set for each day should be as presented for running 1 above.

5. Compute the mean elevation difference for the running, in the forward direction along the line:

$$\Delta H = (\Delta h_A - \Delta h_B) / 2.$$

As explained in subchapter 4.1, curvature and refraction error are largely eliminated from this result.

Also compute the mean sighting distance for the running:

$$S = (S_A + S_B) / 2.$$

Closing the crossing. Check the runnings for closure, as described in section 3.7.7. Make additional runnings until the section is closed within the tolerance for the order and class of the survey (table 3-1). All records should be filed with the other observation records for the line of leveling.

4.4 Instructions for Ordinary Leveling Instruments

In 1929 the Coast and Geodetic Survey published an observing routine suitable for performing river crossings with the Fischer level, the leveling instrument in

use at the time. The routine employs the basic procedures necessary for a precise crossing: multiple observations of targets, simultaneous reciprocal observations from two instruments, and reciprocal collimation by interchanging the instruments from one side to the other. Since the instruments must be interchanged and since the targets are mounted on leveling rods directly over the bench marks, the routine requires that the site meet criteria (sec. 4.2.1) which are somewhat less flexible than those for the Zeiss River Crossing Equipment. The routine is presented here for use (with suitable leveling equipment) when less than first-order precision is required and the Zeiss equipment is not available.

4.4.1 Equipment and Setups

At each side of the crossing, one leveling instrument, one leveling rod, and two targets should be available. Position each instrument across from the rod on the bench mark at the opposite side. A correct pair of setups is illustrated in figure 4-20. The foresights from each instrument to the opposite rod must be as equal in length as possible and within 1 m (3.3 ft) in height.

Instrument. After performing a collimation check (sec 3.3.7), set up the instrument as usual, placing the

RIVER CROSSING
Zeiss Valley Crossing Equipment

42

| | | |
|-----|-----|-----|
| YR. | MO. | DAY |
| 80 | 07 | 08 |

FROM

| | | | |
|---|---|---|---|
| 0 | 1 | 3 | 3 |
|---|---|---|---|

 CAISSON USE (BM A) TO

| | | | |
|---|---|---|---|
| 0 | 9 | 0 | 0 |
|---|---|---|---|

 WINDSOR (BM B)

RUN 1

| | |
|-------|------|
| TIME | |
| BEGIN | END |
| 0100 | 1205 |

| LEVELING At Side B: | Δh | S |
|-----------------------|------------------------|-------------|
| Before F | <u>-1.41618</u> | <u>40.5</u> |
| Before B | <u>+1.41620</u> | <u>40.5</u> |
| After F | <u>-1.41622</u> | <u>40.3</u> |
| After B | <u>+1.41620</u> | <u>40.3</u> |
| Height Stud B to BM B | <u>-1.41620</u> (Mean) | <u>40.4</u> |

| LEVELING At Side A: | Δh | S |
|-----------------------|------------------------|-------------|
| Before F | <u>+0.48137</u> | <u>12.4</u> |
| Before B | <u>-0.48165</u> | <u>12.0</u> |
| After F | <u>+0.48150</u> | <u>12.4</u> |
| After B | <u>-0.48167</u> | <u>12.8</u> |
| Height Stud A to BM A | <u>+0.48155</u> (Mean) | <u>12.4</u> |

SERIES At Side A:
BM A to Height Stud B +0.07250 703.0

BM A to BM B = $\Delta h_A =$ -0.96675 $S_A =$ 743.4

SERIES At Side B:
BM B to Height Stud A +0.43665 693.7

BM B to BM A = $\Delta h_B =$ +0.91820 $S_B =$ 706.1

$$\Delta H = \frac{1}{2} \times (\Delta h_A - \Delta h_B) = \underline{-0.94248} \text{ m}$$

$$S = \frac{1}{2} \times (S_A + S_B) = \underline{0.72} \text{ km}$$

Figure 4-19.—Computation of river crossing with Zeiss River Crossing Equipment.

tripod firmly in the ground to ensure that it does not move throughout the crossing routine. The instrument must be equipped with a mechanism for precisely measuring the tilt of the line of sight. The mechanism of the Fischer level is an example of the type required.

The Fischer level (fig. 4-21) is equipped with a precise tilting screw, normally used to center the bubble in the level vial. The screw is graduated to serve as a micrometer, one unit representing one hundredth of a rotation. The position of rotation can be estimated to one tenth of a unit, which in the 1934 model corresponds to a tilt in the line of sight of approximately 0".5. This precision is compatible with the precision with which the bubble may be centered. Thus, the tilting screw may be read to measure a tilt of the line of sight as small as $\pm 0".5$.

A compensator instrument does not usually possess such a mechanism. The compensator cannot be "tilted" by any means analogous to the tilting screw. An alternative mechanism is the rotary wedge (sec. 4.3.1) but this attachment is not available for most instruments.

Rod. Set a leveling rod on the nearby bench mark. Either rod 1 or rod 2 of the standard pair may be used, since only the low scale is required. Plumb and guy the rod in place with three wires attached at the top center. Rotate it to face the instrument on the opposite side.

Targets. Use two targets that satisfy the requirements given in subchapter 4.1, "Intercepting targets." To permit precise measurement of the target's height against the rod scale, an index line should be clearly marked at the centerline of each target.

Mount the targets securely on the leveling rod. Position one target above and one below the estimated intercept of the horizontal line of sight from the instrument on the opposite side. The distance between the targets should be no more than 1.0 m (3.3 ft) and should be similar to the corresponding distance on the opposite side of the crossing. The angle of tilt from horizontal to each target should be at least $\pm 100"$ (20 units on the tilting screw of the Fischer level). Consult with the observer on the opposite side to ensure that these conditions are satisfied.

Enter the positions of the targets in rod units at the top top of the recording form for the first series. If possible, communicate these heights to the recorder on the opposite side.

4.4.2 Observing Routine for Two Targets (Three-Wire Leveling)

One running of this crossing routine includes two sets of simultaneous reciprocal observations. The locations of the instruments for the first set are reversed for the

second set. The results of each set are meaned to compute the elevation difference for the running.

Two runnings are required for a complete crossing. They can usually be completed in one day (See table 4-3 for a summary of the routine.) Conduct the following procedure simultaneously at each side of the crossing, recording the data on the standard forms for three-wire leveling (fig. 4-22)

1 Prepare the beginning series record (line *42*). Include the following: The survey-point serial numbers

and stampings of the bench marks (designations if no stampings), running number, set number, local time zone and time, temperature units and temperature, wind code, and sun code.

2 BACKSIGHT: Level the instrument and point it toward the nearby rod. Observe and record the intercepts of the three reticle lines with the scale, as for three-wire leveling. Compute the backsight intercept and distance.

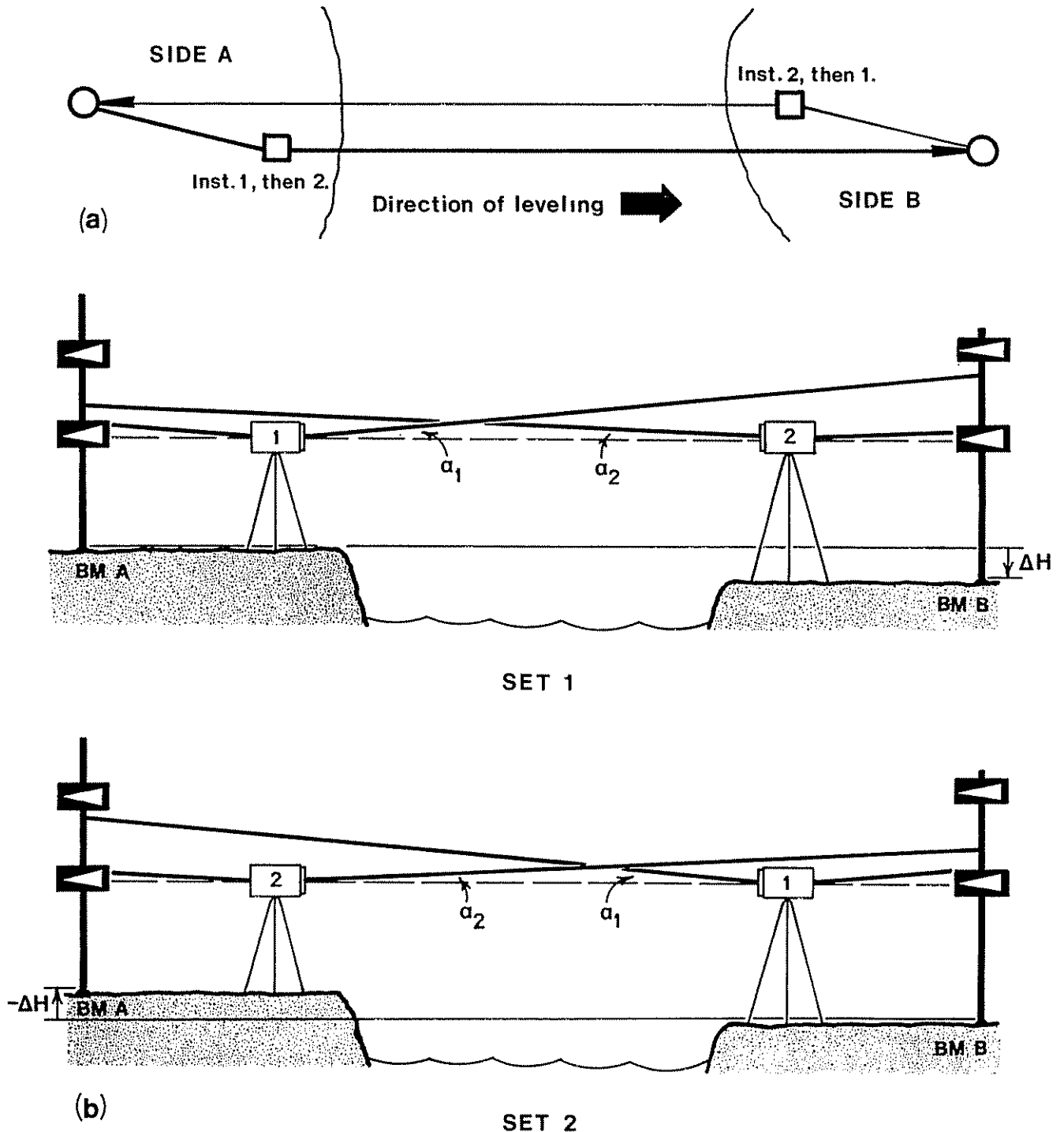

Figure 4-20.—Setups for simultaneous reciprocal observations with ordinary leveling instruments, top view (a) and side view (b). $\Delta H = \frac{1}{2}(\Delta h_{\text{Set 1}} + \Delta h_{\text{Set 2}})$.

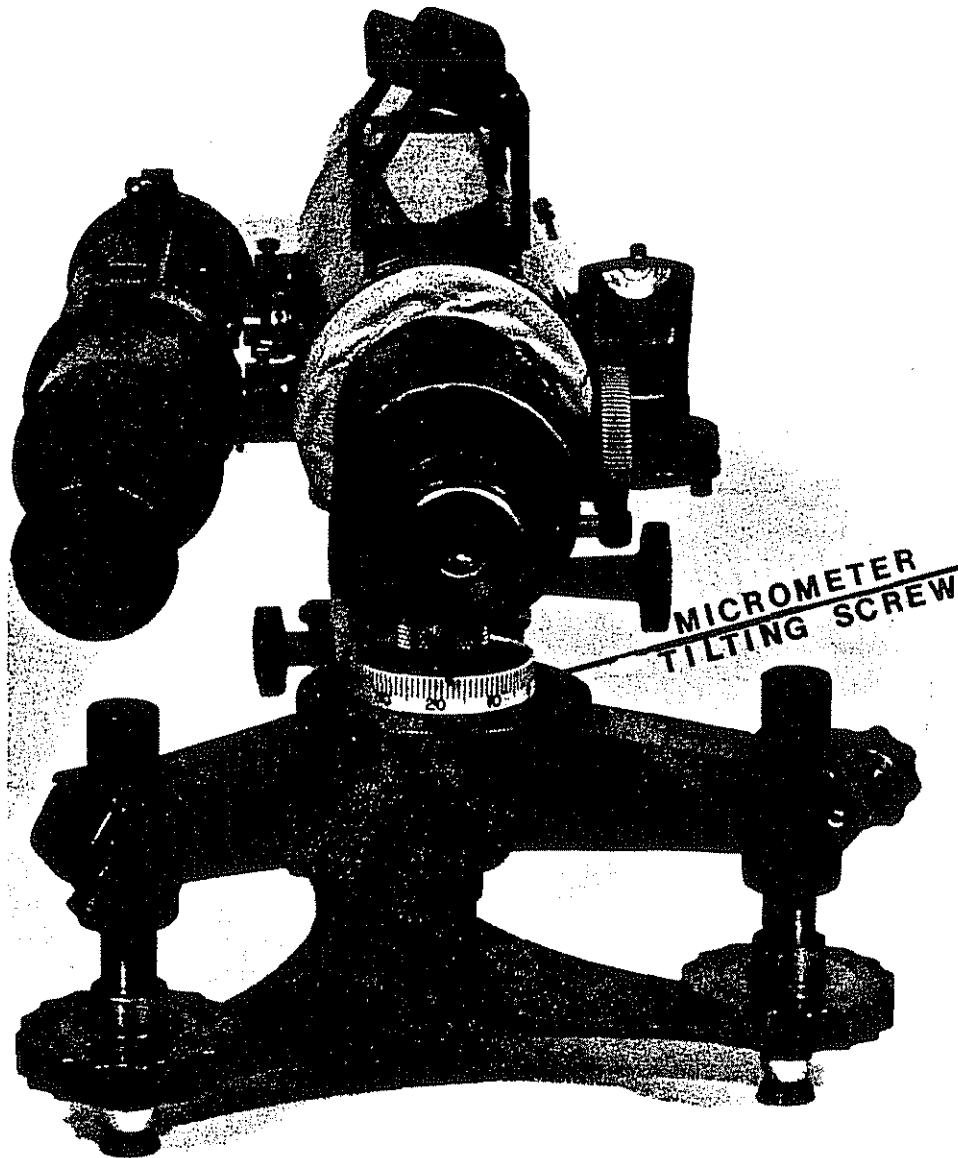

Figure 4-21.—Fischer level, with micrometer tilting screw.

3. FORESIGHT: Check with the observer on the opposite side to begin the foresight observations simultaneously. Point and focus toward the rod on the other side of the crossing. Make 25 sets of three tilt measurements, as follows:

a. Tilt the line of sight to intercept the center of the upper target with the middle reticle line. Read the tilting screw (or equivalent scale) and record the value to the nearest tenth of a unit.

b. Center the bubble in the level vial, bringing the line of sight to horizontal. Read and record the tilt measurement as before.

c. Tilt the line of sight to intercept the center of the lower target with the middle reticle line. Read and record the tilt measurement as before.

4. Compute the foresight intercept and distance:

a. Compute the mean tilts to the upper and lower targets and to horizontal (fig. 4-2): a , b , and r , respectively.

b. Obtain the heights of the opposite targets and compute the difference between them, D .

c. Compute the distance, h , from the lower target to the intercept of the horizontal line of sight:

$$h = D \times (b - r) / (b - a).$$

d. To h , add the height of the lower target to obtain the foresight intercept in rod units.

e. Compute the foresight distance by the formula:

$$s_F = [(b - a)_{\text{tilt units}} \times \text{conversion factor}_{\text{radian/tilt unit}}].$$

For example, with the 1934 Fischer level (0.000025 radian/tilt unit) and centimeter rod units:

$$s_F = (400 \times D) / (b - a).$$

Table 4-3.—Summary of the crossing routine for ordinary leveling instruments

During each running, on each side of the crossing

- 1 Collimation check.
- 2 Set up instrument station and leveling rod
- 3 Position targets above and below level line of sight from opposite instrument
- 4 Observe backsight to nearby rod (1 set of readings)
- 5 Observe foresight series to opposite rod (25 sets of readings)
- 6 Move instrument to opposite side. Do not change focus
- 7 Observe foresight series to opposite rod (25 sets of readings)
- 8 Observe backsight to nearby rod (1 set of readings)

During one day

| | | | |
|---|---|--|------------------------|
| Side A COLLIMATION CHECK INSTRUMENT 1 } INSTRUMENT 2 } INSTRUMENT 2 } INSTRUMENT 1 } | Side B COLLIMATION CHECK INSTRUMENT 2 } INSTRUMENT 1 } INSTRUMENT 1 } INSTRUMENT 2 } | SET 1 } SET 2 } SET 1 } SET 2 } | RUN 1 RUN 2 |
|---|---|--|------------------------|

| HOAA FORM 76-189 (4-77) | | | | | | | | | | TARGETS THIS SIDE (A) AT 143.0 CM AND 193.0 CM. | | | | | | | | | | U. S. DEPARTMENT OF COMMERCE NATIONAL OCEANIC AND ATMOSPHERIC ADMINISTRATION | | | | | | | | | | PAGE | |
|-------------------------|--|-----------------|--|-------|--|-----------------------|--|----------------------|--|---|--|---------|--|----------------|--|-----------------------|--|---|--|--|--|---------------------------|--|--|--|--|--|--|--|------|--|
| RUN 1 SET 1 | | | | | | | | | | GEODETIC LEVELING THREE-WIRE OBSERVATIONS <i>EXAMPLE</i> Second order, Class I RIVER CROSSING | | | | | | | | | | 2 OF 5 | | | | | | | | | | | |
| * A O * | | YR. / MO. / DAY | | CODE | | INSTRUMENT SERIAL NO. | | CODE | | ROD SERIAL NO. | | CODE | | ROD SERIAL NO. | | Fischer Instrument | | | | 2 | | 820 | | | | | | | | | |
| * A 5 * | | 8/02/28 | | 211 | | 74 | | 312 | | 368 | | 312 | | 387 | | Rod UNIT = centimeter | | | | | | | | | | | | | | | |
| FROM | | BM DESIGNATION | | TO | | BM DESIGNATION | | Z | | TIME | | C | | TEMPERATURE | | W | | S | | DU-SERVER | | | | | | | | | | | |
| 0001 | | A 133 | | 0002 | | B 133 | | 0 | | 10221038 | | C | | 180 | | 1850 | | 1 | | 6 | | WW | | | | | | | | | |
| BACKSIGHT | | | | | | | | | | FORESIGHT | | | | | | | | | | COMMENTS | | | | | | | | | | | |
| SET UP | | UPPER | | MEAN | | BACK CENTER | | S _U | | UPPER | | MEAN | | BACK CENTER | | S _U | | | | | | | | | | | | | | | |
| | | MIDDLE | | | | | | S _L | | MIDDLE | | | | | | S _L | | | | | | | | | | | | | | | |
| | | LOWER | | | | | | | | LOWER | | | | | | | | | | | | | | | | | | | | | |
| | | Σ | | Σ | | | | Σ | | Σ UPPER | | Σ LEVEL | | LOWER | | Σ | | | | | | | | | | | | | | | |
| | | 84.4 | | | | | | | | 22.8 | | 49.0 | | 72.8 | | | | | | | | OPPOSITE TARGETS = 127.00 | | | | | | | | | |
| 1 | | 83.3 | | 83.30 | | 27.3 | | 1.1 | | 22.8 | | 48.8 | | 72.8 | | | | | | | | Σ 9.1 | | | | | | | | | |
| | | 82.2 | | | | | | 1.1 | | 22.8 | | 48.7 | | 72.8 | | | | | | | | a = 22.36 | | | | | | | | | |
| | | 249.9 | | 83.30 | | | | | | 22.8 | | 48.8 | | 72.8 | | | | | | | | | | | | | | | | | |
| | | 3. | | | | | | x 332 | | 22.7 | | 48.6 | | 72.5 | | | | | | | | LEVEEL = 6.8 | | | | | | | | | |
| | | 83.30 | | | | | | = 730.4 | | 22.5 | | 48.4 | | 72.4 | | | | | | | | Σ = 48.27 | | | | | | | | | |
| | | 100.02 | | | | | | = 100. | | 22.5 | | 48.6 | | 72.5 | | | | | | | | | | | | | | | | | |
| | | 16.72 | | | | | | S _B = 7.3 | | 22.8 | | 48.7 | | 72.6 | | | | | | | | | | | | | | | | | |
| | | 100. | | | | | | + 416.5 | | 22.5 | | 48.1 | | 72.3 | | | | | | | | LOWER = 75.00 | | | | | | | | | |
| | | Δh = 0.1672 m. | | | | | | S = 423.8 m | | 22.2 | | 48.0 | | 72.1 | | | | | | | | Σ = 7.6 | | | | | | | | | |
| | | | | | | | | | | 22.2 | | 48.1 | | 72.0 | | | | | | | | b = 72.30 | | | | | | | | | |
| | | | | | | | | | | 22.1 | | 48.0 | | 72.2 | | | | | | | | | | | | | | | | | |
| | | | | | | | | | | 22.1 | | 48.0 | | 72.1 | | | | | | | | | | | | | | | | | |
| | | | | | | | | | | 22.1 | | 48.1 | | 72.0 | | | | | | | | | | | | | | | | | |
| | | | | | | | | | | 22.4 | | 48.2 | | 72.5 | | | | | | | | 24.03 | | | | | | | | | |
| | | | | | | | | | | 22.1 | | 48.1 | | 72.1 | | | | | | | | 49.94 | | | | | | | | | |
| | | | | | | | | | | 22.1 | | 48.1 | | 72.1 | | | | | | | | 6 - a = 25.02 | | | | | | | | | |
| | | | | | | | | | | 22.2 | | 48.0 | | 72.1 | | | | | | | | + 75.00 | | | | | | | | | |
| | | | | | | | | | | 22.2 | | 48.0 | | 72.1 | | | | | | | | 100.02 | | | | | | | | | |
| | | | | | | | | | | 22.1 | | 48.0 | | 72.1 | | | | | | | | | | | | | | | | | |
| | | | | | | | | | | 22.1 | | 48.1 | | 72.1 | | | | | | | | | | | | | | | | | |
| | | | | | | | | | | 22.2 | | 48.0 | | 72.1 | | | | | | | | | | | | | | | | | |
| | | | | | | | | | | 22.3 | | 48.1 | | 72.1 | | | | | | | | | | | | | | | | | |
| | | | | | | | | | | 22.2 | | 48.0 | | 72.1 | | | | | | | | | | | | | | | | | |
| | | | | | | | | | | 22.1 | | 48.2 | | 72.1 | | | | | | | | 52 x 400 | | | | | | | | | |
| | | | | | | | | | | 22.2 | | 48.2 | | 72.2 | | | | | | | | 49.94 | | | | | | | | | |
| | | | | | | | | | | 22.2 | | 48.2 | | 72.2 | | | | | | | | S _F = 416.5 m | | | | | | | | | |

Figure 4-22.—One side of a set of simultaneous reciprocal observations, three-wire leveling.

5. Prepare the ending series record (line *42*), which includes time, temperature, wind code, and sun code. Compute the elevation difference and the total distance in the same way as for a setup of three-wire leveling.

6. Leaving the tripod and the leveling rod in place, transport the instrument to the opposite side of the crossing. Do not change the focus on the instrument during this operation.

7. Observe and record a second series, this time observing the foresight (steps 3 and 4) and then the backsight (step 2). The leveling instrument should not have to be refocused to observe the foresight. In conjunction with the series from the opposite side, this set completes the first running.

8. Begin the first set of the second running from the same setup. After completing steps 1 through 5, transport the instrument back to the original side and observe a second set. Again, do not refocus the instrument between sets and begin the second set with the foresight.

9. Compute the results for each running on a cover sheet (fig. 4-23). First, mean the results from the two sides in each set. Then mean the results of the two sets to obtain the elevation difference for the running.

10. Check the runnings for closure, as explained in section 3.7.7. Obtain at least two runnings which close within the tolerance for the order and class of the survey.

REFERENCE

Pfeifer, L. and Morrison, N. L., 1980: *Input Formats and Specifications of the National Geodetic Survey Data Base*, vol. II: Vertical control data. Federal Geodetic Control Committee National Geodetic Information Center, NOAA/NOS, Rockville, Md. 20852, 136 pp.

RIVER CROSSING
Simultaneous Reciprocal Observations

42

| | | |
|-----|-----|-----|
| YR. | MO. | DAY |
| 77 | 11 | 28 |

FROM

| | | | |
|---|---|---|---|
| 0 | 0 | 0 | 1 |
|---|---|---|---|

 A 133 (BM A) TO

| | | | |
|---|---|---|---|
| 0 | 0 | 0 | 2 |
|---|---|---|---|

 B 133 (BM B) RUN 1

| TIME | |
|---------|-------|
| BEGIN | END |
| R 10 00 | 10 35 |

| | Δh | S | | Mean of Set |
|-------------------------|----------------|--------------|-------------------|-----------------------------|
| Set 1 | | | | |
| Side A (Instrument 1) F | <u>+0.1800</u> | <u>330.1</u> | Δh ₁ = | <u>+0.1614</u> <u>333.0</u> |
| Side B (Instrument 2) B | <u>-0.1928</u> | <u>336.5</u> | | |
| Set 2 | | | | |
| Side A (Instrument 2) F | <u>+0.1415</u> | <u>335.2</u> | Δh ₂ = | <u>+0.1712</u> <u>337.6</u> |
| Side B (Instrument 1) B | <u>-0.2008</u> | <u>340.0</u> | | |

ΔH = +0.1663 m S = 0.34 km

Figure 4-23.—Cover sheet for a running with ordinary equipment.

Chapter 5

PROJECT DATA PROCESSING

5.1 Introduction

Vertical control data should be compiled, checked, and edited as soon as possible after collection. To be included in the National Geodetic Vertical Network, the data should be formatted according to *Input Formats and Specifications of the National Geodetic Survey Data Base* (Pfeifer and Morrison, 1980: vol. II). These tasks, collectively termed "processing," must be performed so thoroughly that, after the project is complete and survey personnel have left the area, data may be verified and adjusted and elevations may be published without additional field work.

5.2 Organizing a Project Office

To correct mistakes, resolve discrepancies, and ensure compliance with project instructions, processing should take place in a locale that permits immediate communication with and monitoring of both mark setting and leveling units. A project office, centrally located within the project area, serves this purpose. It includes the personnel and equipment necessary to support and monitor mark setting and leveling units while processing their data. The mobile field offices of the National Geodetic Survey must perform many administrative and processing services in addition to those described here. [See National Geodetic Survey Operations Manual (Greenawalt and Floyd 1980) for further details]

5.2.1 Personnel

The project office normally requires a project director, an assistant project director, and, if many units are operating, an assistant computer.

Project director. The project director is responsible for ensuring that project goals are achieved. The project director's duties include planning and coordinating the activities of the mark setting personnel and leveling units, establishing liaison with local officials, directing the processing effort, assigning reruns as necessary, reporting monthly accomplishments, and preparing a final project report. The director should visit each unit during a workday at least once a month, not only to check for compliance with procedural specifications, but to provide feedback concerning the quality and progress of the unit's work and to provide training as appropriate.

Assistant project director. The assistant project director ("computer") is primarily responsible for compiling, checking, and editing the data submitted by the

mark setting and leveling units. This individual must be well-organized, attentive to detail, and adept at operating the necessary computers. A thorough understanding of mark setting and leveling practices is vital to successful and efficient troubleshooting when discrepancies are found in the data. A computer-processing system cannot substitute for this type of understanding, which is gained best from experience in the field.

Assistant computer. In a large project requiring many leveling units for its timely completion, an assistant computer contributes the added staffing necessary to keep the processing up-to-date. This position is suitable for rotational training of senior mark setting and leveling personnel, permitting them better to understand the significance of their work and the purposes behind many field specifications. An individual who has served as an assistant computer is better prepared to supervise a unit conducting a special project at a location remote from the project office.

5.2.2 Equipment for Data Processing

In addition to standard items of office equipment, the project office should be equipped with the specialized desk calculators, computer system, and telephones necessary to process data efficiently. If leveling data are recorded with a computer in the field, at least one matching system should be available in the office for troubleshooting purposes.

If all data are handwritten on forms or in books and are not to be keyed into a computer data base, a programmable desk calculator is sufficient for processing. It should have a large keyboard and display, as well as an option for printing. Such a calculator is also useful for preliminary analysis of computer-recorded data.

For processing computer-recorded data the following components are essential: A terminal with a keyboard and a CRT display, which is preferable to a printer for on-line editing; a data retrieval and storage unit, such as a reader for magnetic tape or disks; a high-speed printer capable of producing permanent copy; and the computer itself. The high-speed printer and the computer, if not physically located at the office, may be accessed by telephone. This requires either a "dataphone" or a standard telephone used in combination with an acoustic interface. Arrangements must be made for printouts to be forwarded to the project office when they are needed.

Study the maintenance and operating instructions that accompany the computer system. Learn how to connect various components together and how to set

the switches correctly for different modes of operation. In particular, learn the symbols or "error flags" generated when the hook-up or switch configuration is incorrect. Do not confuse these with flags generated as a result of errors in data. Much frustration and loss of time can be prevented if mistakes in maintenance and operating procedure are quickly recognized and corrected.

Computer equipment may operate erratically or fail when exposed to dust, extreme heat, power fluctuations, static electricity, and vibration. Keep the project office clean, the temperature moderate, and electrical cables and outlets in good condition. Clean keyboards and recording heads weekly. Ground all computer components. Check cables and outlets on office trailers frequently, since they may suffer from exposure to weather during moves. Have available a list of local servicing agents and their phone numbers so repairs may be obtained quickly.

The computer itself must be protected from power fluctuations, especially if a temporary loss or reduction of power results in loss of memory or circuit damage. For a computer installed in the project office, an uninterruptible power source with a backup battery bank may be necessary. Voltage regulators are sufficient for most other components.

If a telephone line is used to transmit data to a computer at another location, interference occasionally causes loss of data. At the project office, have available backup on paper, tapes, or other media so lost items of data may be restored after transmittal.

Magnetic tapes and disks. Before the project begins, prepare a sufficient supply of the magnetic tapes or disks on which data are to be recorded and stored. Label each with the job code plus a unique number. This identifier should be written on the backup form for any data recorded directly on a tape or disk by the leveling unit. Similarly, the identifier for a tape or disk on which data are stored in the project office should be noted on the status sheet for each file of data. Such a cross-referencing system is especially helpful when processing data for numerous leveling units or lines.

Most tapes or disks may be reused. Indicate each use by placing a small check next to the identifier. After a day's set of observations has been printed, checked, and recomputed, the tape or disk may be erased. Tapes or disks containing backup files of data for the project should be not be erased and reused until notice is received that the data have been stored in the data base. Depending on the quality of the media, the chances of acquiring errors due to dirt or strain on a tape or disk increase each time they are reused. Do not use a tape more than five times.

5.2.3 Organizing the Data

Organize preliminary data for the project as well as original records received from the field. A logical and well-maintained filing and labeling system permits pro-

cessing to proceed systematically and efficiently, especially when the project office supports numerous units operating on many different lines.

Preliminary data. One copy of each of the items listed and discussed in section 2.3.1 should be available at the project office. In addition, obtain from the National Geodetic Survey abstracts of unadjusted, corrected observed elevations for all previous leveling surveys in the project area. These are called "phase one abstracts" or "summary sheets." They are identified chronologically by accession number ("L-number"). Consult the indexes of the appropriate 30' quadrants of Vertical Control Data to determine the accession numbers to order.

File quadrants of vertical control data, horizontal control data, and summary sheets separately in numerical order. Label each cover sheet with the numbers of the project lines or loops covered. File miscellaneous data, such as tide station reports and unpublished descriptions, by line.

Maintain a notebook or file in which project instructions, correspondence, processing status sheets, statistics, notes, and miscellaneous preliminary data may be stored for quick reference. This is very valuable when preparing the project report.

Index Maps of Control Leveling or Geodetic Control Diagrams are suitable maps to display for an overview of the project area. Highlight and label the project lines and note other useful cross-referencing information, such as accession numbers of past surveys.

Original records. Prior to leveling each line, obtain from the mark setting unit bound volume of descriptions for all control points to be leveled, a set of smooth plots, and a set of logs, prepared as described in sub-chapters 2.3 and 2.4. On a daily basis, obtain from the leveling unit observations and computed elevation differences for each section, recorded as described in sub-chapters 3.7 and 3.8. If the unit transmits data over a telephone line directly into the computer, obtain a backup tape, disk, or printout daily. The unit should also submit pages of the handwritten field abstract as they are completed.

Store original records in a fireproof safe or file as soon as they are received. The storage container should protect computer-recorded data from magnetic interference as well. Store daily data packages in chronological order. Store backup tapes or disks in numerical order and maintain an index of their contents. Store master program tapes or disks in the same protective location.

Original recording forms and printouts of original observation records are repeatedly referred to during processing in the project office and, later, during verification and adjustment. To protect the records and make them readily accessible, bind large quantities of forms and printouts chronologically into volumes of manageable size that correspond, if possible, to the files of data stored on the computer. File small quantities (such as records for a river crossing) in labeled envelopes.

Editing original records. Make notes and corrections on original records with ink of a different color from that used in the field. Each individual who performs editing should adopt a color, such as red or blue, and use it throughout the project. Do not repeatedly mark changes when trying to resolve a discrepancy. Show the final correction and affix your initials.

Once records are stored in computer memory, they may be inadvertently altered. Whenever a record is edited in the computer file, note the change on the original recording form or on a printout of the original computer-recorded data. The note must explain the change. For example, if a distance is remeasured to resolve a discrepancy in a description, state this fact. If a survey-point serial number is changed, explain why the original number was wrong and why the new number was chosen. If there is no backup record or other means to validate a change, do not alter the record.

Identifying the data. Key items of identifying information must be given in the heading or on the cover sheet for each file of data. Heading requirements for data stored in computer files are explained in *Input Formats and Specifications of the National Geodetic Survey Data Base* (Pfeifer and Morrison 1980: vol. II).

For adjustment purposes, each project is assigned a job code in the project instructions. Use the code to identify the beginning and ending of each file of data stored on magnetic tape or other media.

Every survey included in the national vertical network is assigned a unique accession number. Normally, each line of leveling is assigned a separate accession number. However, if a survey covers a small area and includes multiple lines, the entire project may be assigned a single accession number, in which case each line is assigned a "part number."

An accession number includes the letter "L" and five numerals. A part number is indicated by appending the letter "L" and the line number to the accession number. For example, "L20815.L1" or "L1302-L5".

If the project instructions include accession numbers, use them to identify the data for each line. If they are not assigned, use line numbers until accession numbers become available.

A group of lines is normally assigned an area title in the project instructions. (See fig. 2-3.) The area title must be included in the heading of each file of data for the group. Likewise, the line title, also assigned in the project instructions, must be included in the heading of each file of data for a line. Change the line title as appropriate to indicate the actual direction and route of leveling, but do not change the area title.

Neatly label each binder of original or supporting records for a line with the job code and line number (or accession number if available), name of the corresponding computer file, project title including the state, beginning and ending dates of leveling on the line, accounting task number, agency acronym and field party name, and the initials of the project director. (See fig. 5-1.)

| | |
|--------------------------------|-----|
| *C2*L23021.L2.HGF1 | |
| BASIC NET A, REGION 1, GEORGIA | |
| 8/2/78 - 10/5/78 | |
| NGS Field Party G-37 | DCF |
| Task 8362241V | |

Figure 5-1.—Sample label for project records.

5.2.4 Submitting Data to the National Geodetic Survey

Project data for inclusion in the National Geodetic Vertical Network should be submitted to the National Geodetic Survey in the formats specified. This permits efficient verification and adjustment.

Data should be recorded on the standard forms illustrated in the examples throughout this manual. Blank forms are included at the end of the manual. Such records may then be keyed onto magnetic tape or other media for entry into the data base. Data recorded in a computer may be formatted either during leveling or during processing. If computer-recorded data are submitted, include all supporting documents, such as backup forms and printouts, showing the changes made during processing.

Records for submission. Submit the following original records for each line:

1. Descriptions, bound in line order. For points not leveled, submit descriptions bound by areas corresponding to the Geodetic Control Diagrams.
2. Rough plots or map-type logs, numbered in line order.
3. Smooth plots, numbered in line order.
4. Leveling observations, bound chronologically, including a cover sheet for the line, collimation and compensation checks for the instruments, and calibration records for the rods. If observations are recorded with a computer, submit bound sets of both the original printouts of the data and any backup forms that have been prepared. If calibrations are performed at the National Bureau of Standards, the records should be forwarded directly to the National Geodetic Survey.
5. River crossing observations, as in item 4.
6. Field abstract sheets, bound in line order. If the abstract is computed directly from computer-recorded observations, submit the final printout; in this case a hand-written abstract need not be submitted.
7. Comparison of new and old elevation differences along the line, showing ties.
8. Project report.

If data have been formatted according to NGS, in addition to the original records for each line, submit two complete data sets for the project on magnetic tape or other media. One set should include files of descriptive data and the other files of leveling results.

If the files are entered directly into the National Geodetic Survey computer system during the project, prepare and transmit a release letter, identifying the files

that may be accessed for verification at headquarters, immediately after processing each line as described in this chapter. Release computer-recorded observations (HG files), a description file (HAFF), and a file of leveling results (HGZAB). Arrange for obtaining printouts of these records from headquarters. An example is shown in figure 5-2.

Forward all records to the Quality Control Branch (C174) of the National Geodetic Survey. Prepare and forward a memorandum of transmittal (fig. 5-3) itemizing the records sent and the files released. Include a copy of the letter in each package. Send records by registered mail, requesting a return receipt. At the project office retain backup tapes or printouts sufficient to reconstruct lost records, until notification is received that the records have been archived.

Project report. The project report is a permanent record that summarizes project accomplishments. It describes the specific equipment and procedures employed to meet project conditions and requirements. The report provides information useful for verification and adjustment, including detailed explanations of unusual or special features of the project lines. If a project extends over more than one season, prepare a separate report for each season's work. The report should specifically cover the following items:

1. Title page. List the type of report (season or project), project title including the State, accounting task number or numbers, beginning and ending dates of field work, agency name, all HGZ L numbers that are included in the report, field party name, and the name of the project director.

2. Authority and purpose. State the date and title of the project instructions and the date project instructions were received. State the purpose of the survey.

3. Location. Briefly describe the project area, including the State or States in which it is located. Note the number of lines, their general configuration, and their total distance. Also indicate where the project office was located.

4. Scope. State the beginning and ending dates of the survey and the extent to which the project requirements were satisfied.

5. Personnel. List all personnel who participated, including their major duties, and dates of departure or arrival if they did not participate in the entire project.

6. Statistics. Present progress statistics for mark setting, including the following: total distance of lines routed, total number of control points searched for and set, and totals of recovered control points that will be leveled, bench marks set in bedrock, bench marks set in structures, sleeved rod marks set, and unsleeved rod marks set. Also list the totals of recovered points that will not be leveled, points destroyed, points not recovered, and staff days devoted to reconnaissance and mark setting.



UNITED STATES DEPARTMENT OF COMMERCE
National Oceanic and Atmospheric Administration
 NATIONAL OCEAN SURVEY
 Rockville, Md 20852

22 March 1982

TO: C174
 FROM: Level Party G-35 *RNH*
 SUBJ: Release of files for South Region 4, SAN ANTONIO--DEL RIO--JUNCTION--BRADY--
 FREDERICKSBURG TX AREA, L24551.L2--DEL RIO VIA ROCK SPRINGS AND JUNCTION
 TO BRADY TX, Task Number 83624100

The following files and jobs are completed at the field party processing level and are released for further processing.

| JOB CODE | LINE NO. | FILE | JOB NO. | DATE PRINTED |
|----------|----------|-------------------|---------|--------------|
| *D4* | 337 | L24551.L2.HGF1 | 9314 ✓ | 3/22/82 |
| | | L24551.L2.HGF2 | 9309 ✓ | " |
| | | L24551.L2.HGF3 | 9307 ✓ | " |
| | | L24551.L2.HGZFFAB | 731 ✓ | " |
| *D4* | 337 | L24551.L2.HAF1 | 9332 ✓ | 3/22/82 |

CKSPSN of the HA file of Job Code *D4* is Job Number 9317. ✓

Note: All above files are on W3M NGS001 DSN
 cc: C171, C142

Figure 5-2.—Sample memorandum releasing data.

| | | | | |
|--|---------|---|--|---|
| NOAA FORM 61-29 (12-71) | | U. S. DEPARTMENT OF COMMERCE NATIONAL OCEANIC AND ATMOSPHERIC ADMINISTRATION | | REFERENCE NO. NGS36:1981 No 07 sheet 1/2 |
| LETTER TRANSMITTING DATA | | DATA AS LISTED BELOW WERE FORWARDED TO YOU BY (Check): | | |
| TO: Director, National Geodetic Survey ATTN: C174 National Ocean Survey, NOAA Rockville, MD 20852 | | <input type="checkbox"/> ORDINARY MAIL <input type="checkbox"/> AIR MAIL | | |
| | | <input type="checkbox"/> REGISTERED MAIL <input type="checkbox"/> EXPRESS | | |
| | | <input type="checkbox"/> CBL (Give number) _____ | | |
| | | CERTIFIED MAIL | | |
| | | DATE FORWARDED MAY 14, 1981 | | |
| | | NUMBER OF PACKAGES 2 (1 roll & 1 pkg.) | | |
| NOTE: A separate transmittal letter is to be used for each type of data, as tidal data, seismology, geomagnetism, etc. State the number of packages and include an executed copy of the transmittal letter in each package. In addition the original and one copy of the letter should be sent under separate cover. The copy will be returned as a receipt. This form should not be used for correspondence or transmitting accounting documents. | | | | |
| L24562-1 (line 380) GILA BEND VIA SENTINEL AND YUMA AZ TO EL CENTRO CA | | | | |
| pkg 1 (roll) | 27 Maps | USGS topo maps (smooth plotted)* | | |
| | | GILA BEND, ARIZ. SMURR, ARIZ. THEBA, ARIZ. (15') SENTINEL, ARIZ. (15') AZTEC SE, ARIZ. AZTEC HILLS, ARIZ. DATELAND, ARIZ. TEXAS HILL, ARIZ. MOHAWK MTS. NW, ARIZ. MOHAWK, ARIZ. TACNA, ARIZ. WELLTON MESA, ARIZ. WELLTON, ARIZ. LIGURTA, ARIZ. | FORTUNA, ARIZ. YUMA EAST, ARIZ.-CALIF. YUMA WEST, ARIZ.-CALIF. ARAZ, CALIF. GRAYS WELL NE, CALIF.-ARIZ. GRAYS WELL, CALIF. OGILBY, CALIF. (15') MIDWAY WELL, CALIF. MIDWAY WELL NW, CALIF. GLAMIS SW, CALIF. HOLTVILLE EAST, CALIF. HOLTVILLE WEST, CALIF. EL CENTRO, CALIF. | |
| * All topo maps are 7-1/2 minute quads unless otherwise noted. | | | | |
| pkg 2 | 2 Books | NOAA form 76-186 BM Descriptions (book 1, 115 sheets) (book 2-295 sheets) | | |
| | 3 Books | T.I. XOFF sheets for HG files HGF1 (1174 lines) HGF3 (812 lines) HGF5 (776 lines) HGF2 (742 lines) HGF4 (718 lines) HGF6 (564 lines) | | |
| FROM: (Signature) | | RECEIVED THE ABOVE (Name, Division, Date) | | |
| Return receipted copy to: | | | | |
| | | Bob W. Martine National Geodetic Survey P&Sx POB 2141 Orofino, ID. 85344 | | |

Figure 5-3a.—Sample form (NOAA 61-29) accompanying transmitted data.

| | | | | | | | | | | | | | | | | | | | | | | | | | | | | | | | | | | | | |
|--|--|---------------------------------------|-----------|---------------------------------------|--|--|--|----------|----------------------------------|--|--|--|----------|-----------------------|--|--|--|---------|-----------------------------|--------|------------|--|--|--|--------|------------|--|--|--|--------|------------|--|---------|---------------------|--|--|
| <p>NOAA FORM 61-29 (12-71)</p> <p style="text-align: center;">U. S. DEPARTMENT OF COMMERCE NATIONAL OCEANIC AND ATMOSPHERIC ADMINISTRATION</p> <p style="text-align: center;">LETTER TRANSMITTING DATA</p> | <p>REFERENCE NO.</p> <p>NGSG36:1981 No 07 sheet 2/2</p> <p>DATA AS LISTED BELOW WERE FORWARDED TO YOU BY (Check):</p> <p><input type="checkbox"/> ORDINARY MAIL <input type="checkbox"/> AIR MAIL</p> <p><input type="checkbox"/> REGISTERED MAIL <input type="checkbox"/> EXPRESS</p> <p><input type="checkbox"/> GBL (Give number) _____</p> <p>CERTIFIED MAIL</p> <p>DATE FORWARDED</p> <p>MAY 14, 1981</p> <p>NUMBER OF PACKAGES</p> <p>2 (1 roll & 1 pkg)</p> | | | | | | | | | | | | | | | | | | | | | | | | | | | | | | | | | | | |
| <p>TO:</p> <p style="text-align: center;">ATTN: C174</p> | | | | | | | | | | | | | | | | | | | | | | | | | | | | | | | | | | | | |
| <p>NOTE: A separate transmittal letter is to be used for each type of data, as tidal data, seismology, geomagnetism, etc. State the number of packages and include an executed copy of the transmittal letter in each package. In addition the original and one copy of the letter should be sent under separate cover. The copy will be returned as a receipt. This form should not be used for correspondence or transmitting accounting documents.</p> | | | | | | | | | | | | | | | | | | | | | | | | | | | | | | | | | | | | |
| <p><u>L24562-1 (line 380) GILA BEND VIA SENTINEL AND YUMA AZ TO EL CENTRO CA</u></p> | | | | | | | | | | | | | | | | | | | | | | | | | | | | | | | | | | | | |
| <table style="width:100%; border: none;"> <tr> <td style="width:15%;">pkg 2</td> <td style="width:15%;">40 Sheets</td> <td style="width:40%;">NOAA form 75-82A Station Descriptions</td> <td style="width:15%;"></td> <td style="width:15%;"></td> </tr> <tr> <td></td> <td>2 Sheets</td> <td>NOAA form 76-186 BM Descriptions</td> <td></td> <td></td> </tr> <tr> <td></td> <td>7 Sheets</td> <td>New - Old Comparisons</td> <td></td> <td></td> </tr> <tr> <td></td> <td>3 books</td> <td>NOAA form 77-82 40/41 cards</td> <td>book 1</td> <td>140 sheets</td> </tr> <tr> <td></td> <td></td> <td></td> <td>book 2</td> <td>176 sheets</td> </tr> <tr> <td></td> <td></td> <td></td> <td>book 3</td> <td>106 sheets</td> </tr> <tr> <td></td> <td>1 sheet</td> <td>File release letter</td> <td></td> <td></td> </tr> </table> | | pkg 2 | 40 Sheets | NOAA form 75-82A Station Descriptions | | | | 2 Sheets | NOAA form 76-186 BM Descriptions | | | | 7 Sheets | New - Old Comparisons | | | | 3 books | NOAA form 77-82 40/41 cards | book 1 | 140 sheets | | | | book 2 | 176 sheets | | | | book 3 | 106 sheets | | 1 sheet | File release letter | | |
| pkg 2 | 40 Sheets | NOAA form 75-82A Station Descriptions | | | | | | | | | | | | | | | | | | | | | | | | | | | | | | | | | | |
| | 2 Sheets | NOAA form 76-186 BM Descriptions | | | | | | | | | | | | | | | | | | | | | | | | | | | | | | | | | | |
| | 7 Sheets | New - Old Comparisons | | | | | | | | | | | | | | | | | | | | | | | | | | | | | | | | | | |
| | 3 books | NOAA form 77-82 40/41 cards | book 1 | 140 sheets | | | | | | | | | | | | | | | | | | | | | | | | | | | | | | | | |
| | | | book 2 | 176 sheets | | | | | | | | | | | | | | | | | | | | | | | | | | | | | | | | |
| | | | book 3 | 106 sheets | | | | | | | | | | | | | | | | | | | | | | | | | | | | | | | | |
| | 1 sheet | File release letter | | | | | | | | | | | | | | | | | | | | | | | | | | | | | | | | | | |
| <p>FROM: (Signature)</p> <p style="text-align: center;"><i>JF</i></p> | <p>RECEIVED THE ABOVE (Name, Division, Date)</p> | | | | | | | | | | | | | | | | | | | | | | | | | | | | | | | | | | | |
| <p>Return receipted copy to:</p> | | | | | | | | | | | | | | | | | | | | | | | | | | | | | | | | | | | | |

Figure 5-3b.—Sample form (NOAA 61-29) accompanying transmitted data.

For leveling, present the following: total progress along lines, double-run progress, single-run progress, total distance leveled, distance leveled as reruns, number of sections, number of setups, and total staff days devoted to actual leveling.

Also, note the total number of personnel days spent during the project and a breakdown of days spent in the field, office, training, travel, holidays, sick leave, and annual leave. Compute the leveling progress per staff day for the entire project.

7. Liaison. Note major contacts with other agencies and individuals interested in the project. Discuss cooperative efforts and any publicity received.

8. Mark setting. Briefly describe the procedures and equipment used, referring to the manuals followed. If unusual bench marks were set, identify and describe them in detail.

9. Leveling. State the leveling specifications that were in force. Describe the equipment, including a list of instruments, rods, and recording equipment with serial numbers and the dates they were in use.

10. Line narratives. Briefly describe each line, including line number, accession number, beginning and ending dates of mark setting and leveling, topography and climate, features of the routing such as control point spacing and frequency of connections, unusual points leveled, unusual procedures, river crossings, ties established, and results of the comparison of new elevations with those from a previous survey along the same line. Mention specific sections that required additional work as a result of preliminary analysis.

11. Loops. Discuss closures of the leveling with both previous and concurrent surveys. Describe areas which may require additional leveling in the future.

12. Recommendations. Report suggestions for improvements in instructions, equipment, and procedures and recommendations for future work in the project area.

13. Attachments. Include as an attachment to the report a simple sketch of the project area showing completed lines, junctions, and loops. A section of the State Index Map of Control Leveling is sufficient, with progress marked and lines clearly labeled. Also attach the following: A copy of the release letter, a list of errors detected in the synoptic file during processing, sketches showing loop closure computations, and the original copy of the project instructions together with any amendments.

5.3 Processing Descriptions

For each line, the mark setting unit provides three sets of records to the project office: logs, smooth plots, and descriptions. As they are received, the logs and smooth plots should be checked off on the Index to Topographic maps. (See fig.2.6) The logs are forwarded to the leveling unit, which in the course of work checks the information given on them. The smooth plots are used by the project office to check, in part, the information

given in the descriptions. The descriptions themselves are checked by the project office. Descriptions for points not leveled should be processed separately, following the same routine.

The ultimate product of these verification procedures is a set of complete and correct descriptions for all the control points leveled. The steps in processing are discussed next and summarized in figures 5-4 and 5-5.

5.3.1 Creating the Description File

If the project office possesses facilities for checking descriptions with a computer, the first step in processing is to create a file of descriptions for the line. The data supplied by the mark setter on the description forms must first be keyed onto magnetic tape or other media through a computer interface.

The descriptions for a single line typically number several hundred characters; thus numerous typographical errors may be entered inadvertently during keying. To prevent errors from entering the file, provide prompts for each type of data entered. The prompting program should check the responses keyed whenever possible.

After a batch of descriptions is keyed, transfer the data into a computer file. Label the file with the appropriate line number (or accession number) and the letters "HA". For example, "L35.HAF1" or "L23021-L2-HAF1". To simplify processing, all the descriptions for one line need not be put into one file at first. As each file is created, assign a file number in line order: "L35 HAF1", "L35 HAF2", and so forth. After proofreading and editing are completed, the files should be merged into one final file for the line: "L35.HAFF".

The project office may be required to process vertical descriptions for control points that are not leveled. These should be keyed and transferred to a separate file for each area that corresponds to a Geodetic Control Diagram. Label each file with the area code and the letters "HAFF". For example, "CK.HAFF" for the area covered by the diagram NI-11, SAVANNAH.

As each file is created, obtain a printout of its contents. The printout may be generated in conjunction with an initial run of the format-checking program, discussed in section 5.3.2. This printout serves as the reference for proofreading and editing the descriptions. To keep track of the status of editing, stamp the first page with a checkoff list like that in figure 5-6.

5.3.2 Checking Individual Descriptions

Descriptions must be proofread and edited to ensure that the required information is entered, that it is correct and internally consistent, and that it is properly coded and formatted. Without a computer, these items must be checked by systematically and thoroughly proofreading the descriptions, noting changes directly onto the description forms. With a computer, many items may be automatically checked; however, proofreading still plays an important role.

VERTICAL DATA PROCESSING

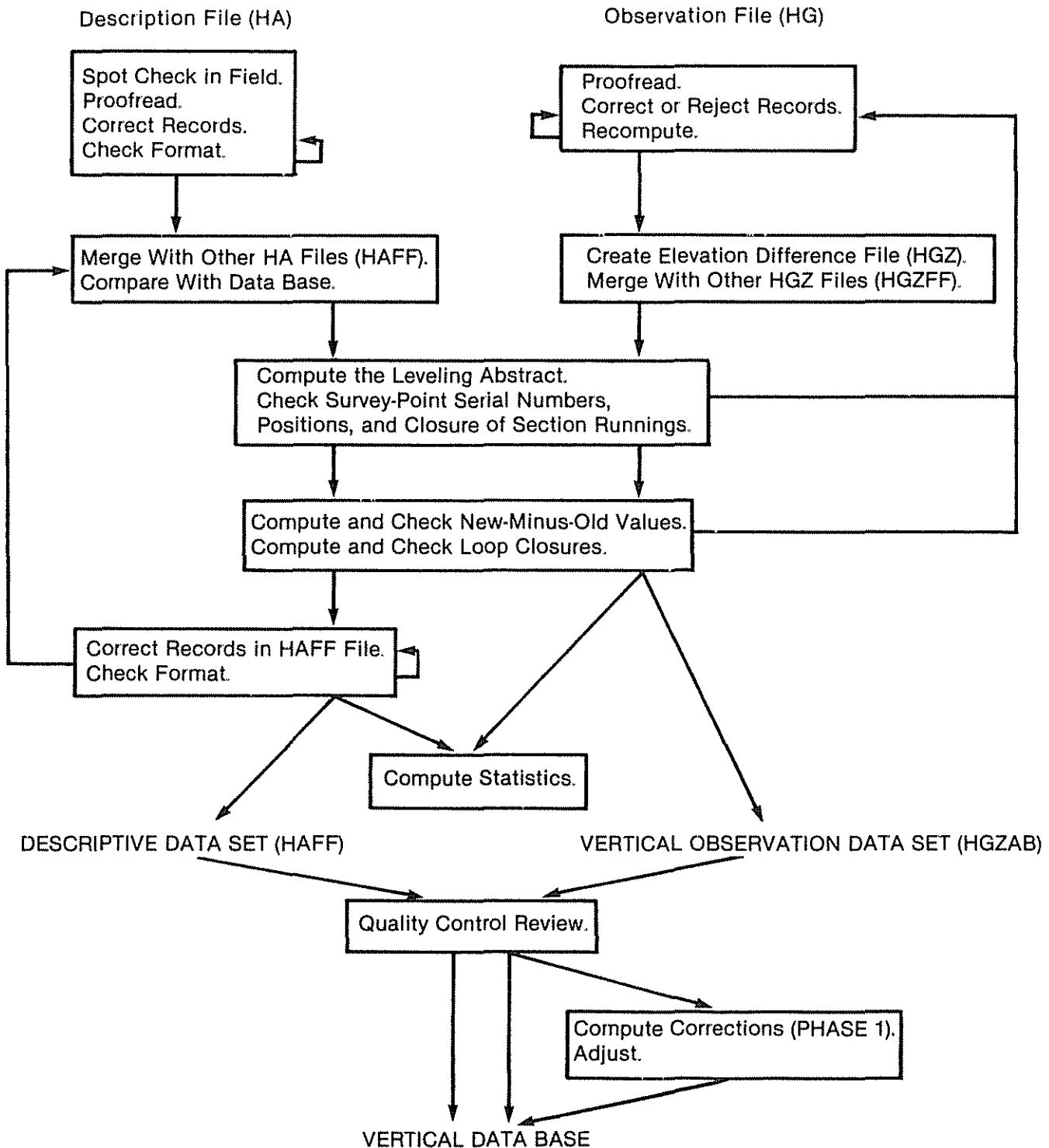

Figure 5-4.—Flow chart of project data processing.

Spot checking. As soon as possible after receipt of the descriptions from the mark setting unit, the mark setting foreman or project director should spotcheck several of the descriptions in the field. In addition to examining the construction of new monuments, check

the choice of routes and the logic of the instructions given. Verify the plotting, the distances and directions, and the physical descriptions of landmarks and reference objects. Note corrections directly on the description forms so the changes are included when keying the

data into a file. If a printout of the file is already available, take the printout to the field and note corrections directly on the printout.

Proofreading. After obtaining a printout of the file as described in section 5.3.1, check the heading. Then read through every description thoroughly, looking especially for errors that may not be detected by a checking program in the computer. Check that the designation is consistent with the stamping. Check and correct the spelling of names of counties, cities, towns, companies, agencies, and individuals. Look for and correct typographical errors, particularly in the text.

Check the internal consistency of the data given, including the following: That the driving distance from the nearest city or town agrees with the total of the driving distances given in the instructions to reach the point; that reference objects are sufficiently described; that distances are given with appropriate precision; and, that distances and directions make logical sense (for example, a point cannot be south of the centerline of one road, east of the centerline of another, and also southwest of their junction). Finally, check that the latitudes and longitudes of all points new to the data base are correct by scaling them from the smooth plots. Refer to the original records whenever necessary to resolve discrepancies. Note points which must be checked during a visit to the field.

When the proofreading is complete and all changes are noted, indicate this fact on the front of the printout. An example of a proofread description printout is given in figure 5-7.

Editing. Next, while on-line to the computer, systematically edit the file. On the printout, check off each change as it is made. On the front of the printout indicate when this preliminary editing is complete. Further editing may be required after running a format-checking program with the computer.

The program should check for the following: all entries are in the correct format, the required information has been given for each type of description, as explained in section 2.4.4, and conversions from metric to English units are correct. After the program is run, the computer should respond with a list of the lines in error and their locations. Correct these systematically, looking up the lines in the printout and noting the changes as they are made to the computer file. Then, rerun the checking program and continue editing until no errors are detected. Note each running of the program on the front of the printout and indicate whether or not a rerun is necessary.

When editing is complete, use the printout as a guide to transcribe all changes directly onto the original description forms. The original records are the only source to resolve discrepancies found in the description file in the future.

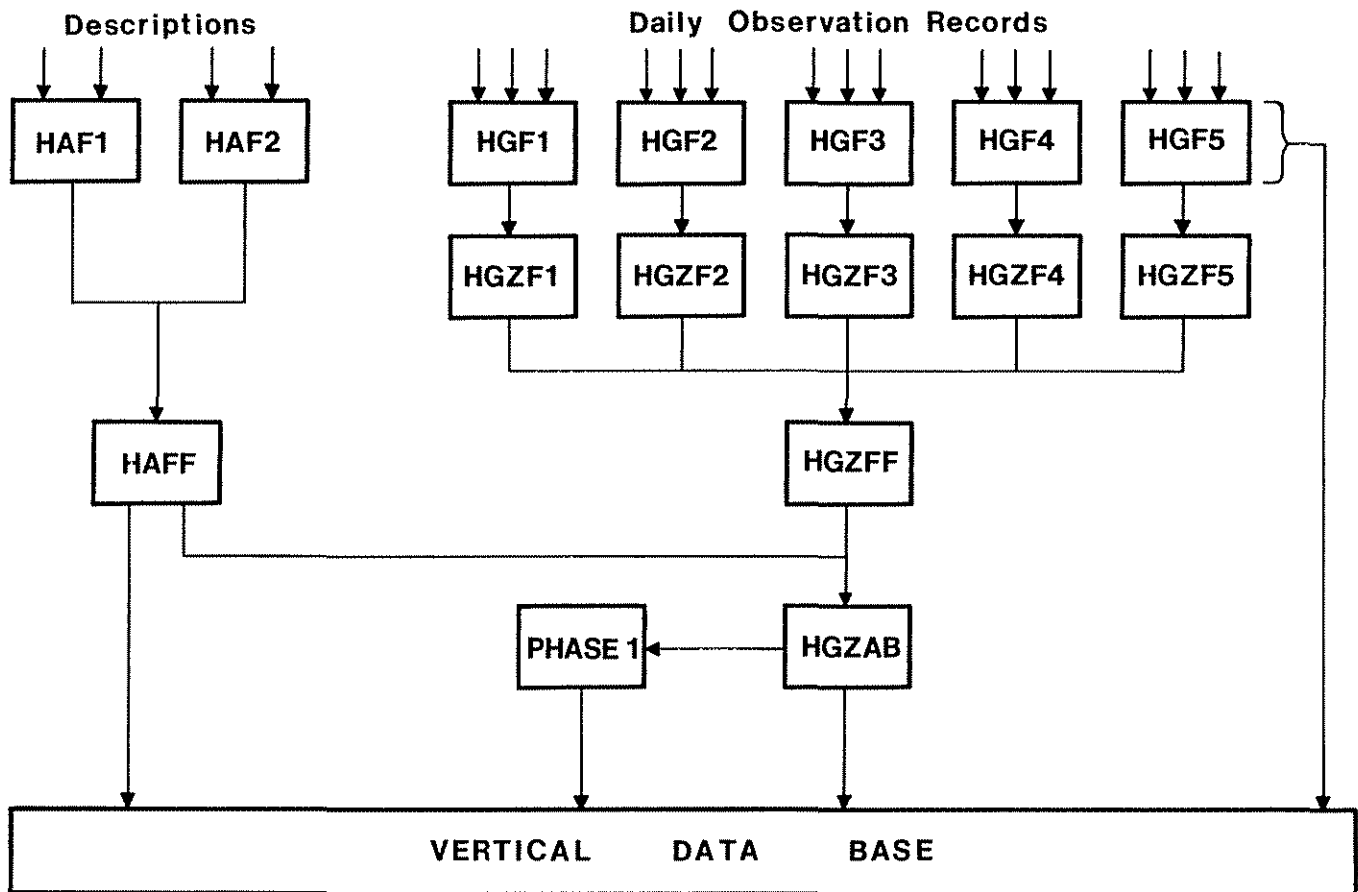

Figure 5-5.—Flow chart of data files for a line of leveling.

| | | |
|----------------------------|--------------------|-----------------|
| FILE <u>L24586.L2 HAF1</u> | | |
| PROOFREAD: | FIRST EDIT: | |
| <u>CUS 3/26/80</u> | <u>CUS 3/26/80</u> | |
| FORMAT-CHECKING PROGRAM: | | |
| JOB# | DATE | RERUN? |
| <u>1321</u> | <u>3/26</u> | <u>Y</u> |
| <u>2018</u> | <u>3/29</u> | <u>Y</u> |
| <u>2025</u> | <u>3/29</u> | <u>N</u> |
| CORRECTED ON ORIGINALS: | | <u>CUS 3/29</u> |

Figure 5-6.—Sample check-off list for station-description editing.

If more than one file exists for a line, merge the files into a final file after all have been completely proofread and edited. At this stage the individual printouts are no longer useful and the processing progress for the file should be recorded on a status sheet (fig. 5-8).

5.3.3 Checking the Entire File

Once the entire file of descriptions for a line is available, it should be checked for agreement with both the existing data base and the observation file for the line.

A file of descriptions for points not leveled must be checked only for agreement with the data base. One or more computer programs may be used to make the checks discussed here. Keep track of their completion on the status sheet.

Synoptic file comparison. The synoptic file is an abbreviated version of the data base, including key items of descriptive information for each control point such as an archival cross-reference number, a designation, aliases, and a position. To ensure that entries for these items in the description file are correct, check them against a listing of the synoptic file. After matching the cross-reference numbers, compare the designations, aliases, and positions. Designations and aliases must satisfy specifications explained in section 2.4.4. Latitudes and longitudes must agree within $\pm 00^{\circ} 00' 06''$.

If the comparison is made by means of a computer program, it should result in a list of records containing discrepancies. Resolve these by listing the appropriate records of the description file and comparing them to both the original records and the published descriptions. Look for typographical omissions and errors (such as transposition of letters or numerals in the designations or cross-reference numbers), incorrect designations, and errors in the plotting or scaling of the positions.

Correct errors found in the description file, noting any changes directly on the original records as well. Include with the release letter (fig. 5-2) a list of errors found in the synoptic file. Do not consider a position given in the synoptic file to be in error until the plotting of the control point has been verified in the field.

```

NEW STATION, DES-REC CODE IS D QID-QSN      - - - -
21      000210*10*1861D294459N0903734W      *11*      *12*      *ZV*
22      000220*13*Y 358                        *14*LA/LAFOURCHE      *ZV*
23      000230*17*RACELAND JUNCTION            *18*5.0 KM (3.0 MI) WEST      *ZV*
24      000240*20*1/NGS                        *21*1982LHW            *22*      *ZV*
25      000250*26*24/STAINLESS STEEL ROD      *27*F      NGS            *ZV*
26      000260*28*Y 358 1982                  *ZV*
27      000270*30*5.0 KILOMETERS (3.1 MILES) WEST ALONG THE SOUTHERN PACIFIC RAILROAD *ZV*
28      000280*30*FROM THE STATION IN RACELAND JUNCTION, TO A SHELL ROAD CROSSING AND *ZV*
29      000290*30*THE MARK ON THE RIGHT, 29.26 METERS (96.0 FEET) NORTH OF THE NORTH *ZV*
30      000300*30*RAIL OF THE TRACK, 3.81 METERS (12.5 FEET) EAST OF THE CENTER OF THE *ZV*
31      000310*30*SHELL ROAD, 1.76 METERS (5.8 FEET) NORTHEAST OF THE NORTHEAST CORNER *ZV*
32      000320*30*OF A RAILROAD TIE CATTLE GUARD, 0.45 METER (1.5 FEET) EAST OF A METAL *ZV*
33      000330*30*POLE WITH A RAILROAD CROSSING SIGN. *ZV*
34      000340*41*M2423.5 F                    *ZV*
35      000350*42*      L SHELL ROAD          *ZV*
36      000360*43*MD. 30W                      *ZV*
    
```

Figure 5-7.—Example of a proofread station description.

Survey-point serial numbers. A line of leveling cannot be correctly abstracted if duplicate or mismatched survey-point serial numbers exist in the line. Run a checking program to detect duplicate serial numbers in the description file, preferably before the line is leveled, so corrections may be made to the logs. Check the remarks in the observation records for duplicates or possible mismatches found in the logs by the leveling unit. Mismatches between the description file and the observation file most often occur as a result of incorrect serial numbers entered in the original observation records. Check for and resolve them as described in section 5.4.2.

Positions. The synoptic file comparison provides a check of the latitudes and longitudes entered for only the control points that are already included in the data base. To check points new to the data base and to check the consistency of all the positions along the line, the positions given in the description file must be compared to the leveling results.

This check is conveniently made when computing the field abstract, as described in section 5.4.2. Compare the straight-line distance between each pair of control points, as computed from their positions, to the leveling distance between them, as computed from stadia observations. The position distance must not be more than 185 m (607 ft) greater than the leveling distance. It should not be less than one third of the leveling dis-

tance, unless the leveling distance is 1 km (0.62 mi) or less. Check the positions of both points in a pair that fails to pass this test.

For each point, scale the latitude and longitude from the smooth plot and compare them to the latitude and longitude given in the description file. They should each agree within $\pm 00^{\circ}00'06''$. Correct any errors, noting changes on the original description form. After finding one point with an incorrect position, check the positions of all points adjacent to it. If any one of them is incorrect, check the positions of all points adjacent to it, and so forth, until the positions of all adjacent points prove correct. This procedure is necessary because, even though an entire group of positions may be scaled incorrectly, only the first point encountered may appear incorrect if the same error has been included consistently in the following positions. (See the examples in fig. 5-9).

If scaling from the smooth plot reveals no errors in the position of either point in the pair, check the plot in the field.

Even if the plotted positions prove to be correct, an error may exist in the observation file. If the survey-point serial numbers assigned to control points in the observation file do not match the serial numbers assigned to the same points in the description file, the leveling distance corresponds to points other than those for which the position distance was computed. Such a case of mismatched serial numbers must be resolved as described in section 5.4.2.

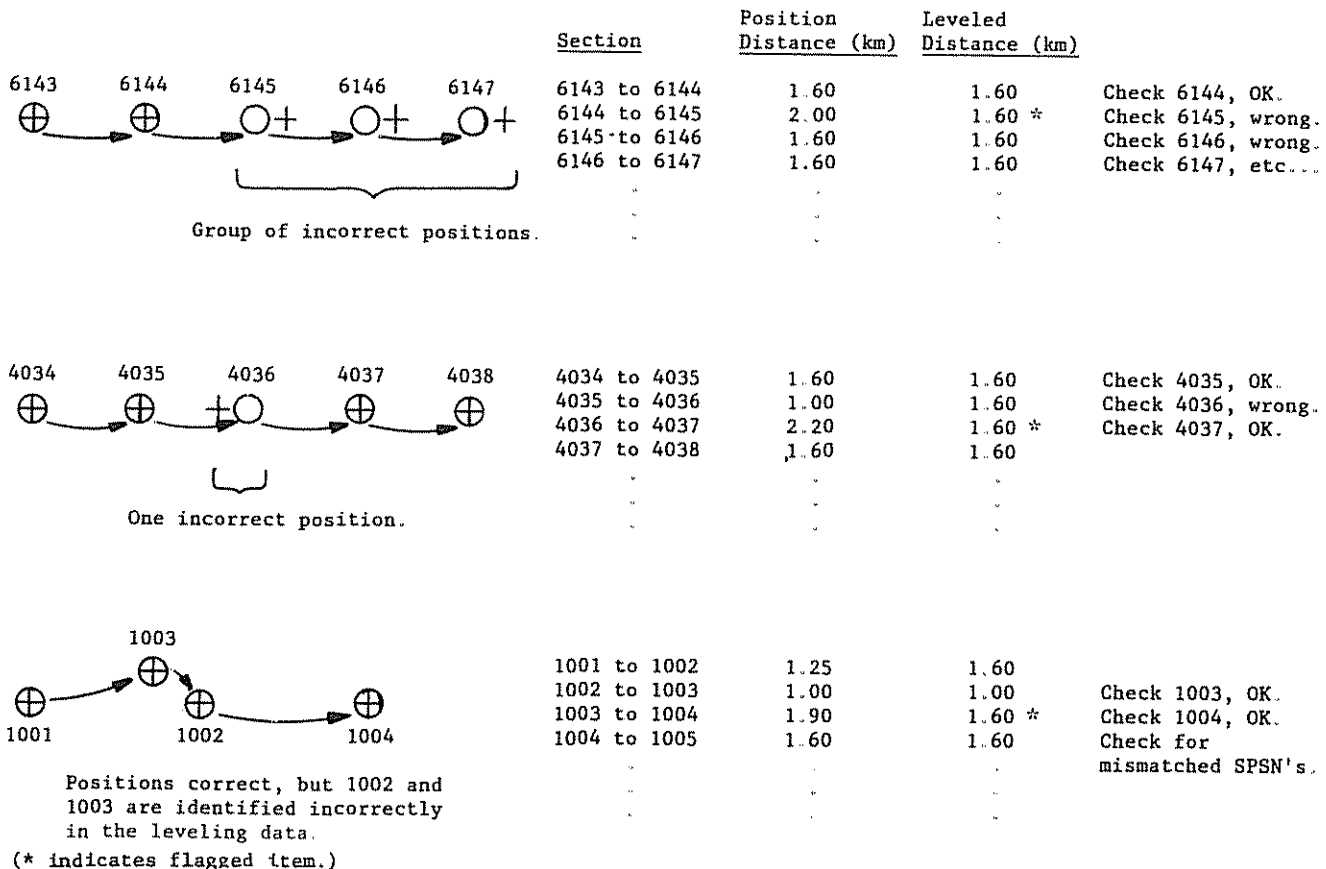

Figure 5-9.—Examples of apparent position errors.

Junction point positions. Check the positions of junction points that begin and end a line for agreement with the positions given in the descriptions for the same points in other lines of the same project. Verify the scaling and plotting of any junction points that do not agree within $\pm 00^{\circ}00'06''$.

Creating the descriptive data set. After all checks and corrections are made, rerun the format-checking program a final time to find and remove any errors that may have been made during processing. The error-free description file is submitted as the descriptive data set for the line.

5.4 Processing Leveling Data

As observations are received from the leveling unit they must be checked promptly to determine if additional leveling is necessary to improve the quality of the results. First, to detect blunders in the information recorded for each section, the observation records must be recomputed and checked. Then, to detect errors that result from blunders not previously discovered, the field abstract must be recomputed and checked. The closure of the leveling line with other lines in the network must be examined. Finally, a statistical summary should be computed and checked. (See figs. 5-4 and 5-5.)

5.4.1 Checking Observation Records

The project office may receive observation records from a leveling unit in person, by mail, or by telephone if they are recorded in a computer. In any case, each package of data should include a single day's observations. Data transmitted by telephone must be followed by a backup tape, disk, or printout sent by mail to the project office. As data packages accumulate daily, note those received on a status sheet maintained for each file (fig. 5-10). Indicate the date of the observations, the date they are received, and the status of their processing.

When observations are recorded with a computer, they may be stored in a computer file and checked automatically with a recomputing program. Even so, proofread printouts of the original observations and handwritten backup forms, if they are used, to find blunders that may not be detected by the program. When records are exclusively handwritten, check them by systematically proofreading and recomputing the observations as they appear on the recording forms.

Creating the observation file. Chronologically collect observations recorded with a computer into an observation file of manageable size. Collect handwritten records similarly. If more than one unit is working on the line, collect each unit's data in a separate file. Label each file with the line number (or accession number), the letters "HG" and the file number. (For example, "L35.HGF1" or "L24032-HGF2") If only one observation file is necessary for the line, label it with the letters "HGFF."

If the unit has not already done so, transmit each day's data to the observation file as soon as possible after receipt. At the same time, obtain a printout of the original observations from the unit or from the tape or disk sent by the unit. The printout provides the only visual backup for restoring items of data lost or altered during transmission. It is also the document on which changes to the observation file must be noted and explained. As printouts accumulate, store them chronologically in a notebook corresponding to the file.

Proofreading. Proofread and compare handwritten recording forms and printouts of original observations as soon as possible after they are received, looking especially for errors in the identifying information.

First, compare the survey-point serial numbers to the stampings given for each control point. The serial numbers in the observation records must agree with those assigned to the corresponding points in the description file. (The abstracting program may check this automatically if stampings are included in the elevation difference file, as in section 5.4.2.) Check for incorrect line numbers, data codes, dates, equipment serial numbers and codes, codes for measurement units, observer initials, time zones, times, and setup numbers. Check for illogical entries of temperatures, wind codes, and sun codes. Finally, check comments and computations entered as remarks.

Correct the records as necessary to agree with backup forms, recorded remarks, the description file, equipment inventories, and weekly reports. Compute interpolated corrections for illogical or omitted times, wind codes, and sun codes from records immediately preceding and following the error. Unless the mistake is clearly a format error, remove the unit code from an illogical or omitted temperature and leave the entry blank. Do not alter rod readings. If any readings are omitted or unclear, reject the section.

Initial each sheet as it is checked and corrected. Explain changes made to the observation file directly on the printout and then systematically edit the file before recomputing.

Recomputing computer-recorded observations. Check the observation file once it is stored in the computer by running a recomputing program. The program must read information in chronological order to run properly. It may terminate if any time zones, dates, times, or data codes are illogical or out of sequence. To save time and prevent frustration, check such sequence data carefully during proofreading and be sure to correct erroneous items before running the recomputing program.

Should the program terminate prior to completion, find the error by examining the record in the observation file at the termination point. Often, during transmission of data, erroneous characters may be inserted into a record. Delete them to restore the correct format. If no format or other error can be found, check to see if an error actually occurs earlier in the file, causing subsequent data to appear incorrect.

The recomputing program should check for and flag as rejected records in which required information is omitted, format errors exist, or recomputed results are not within logical or acceptable limits. For example, it should recompute setup imbalances and reading checks, flagging those that do not satisfy the tolerances specified in the project instructions.

Possible blunders should be flagged by the program, but not automatically rejected. Examples include a scale reading of less than 0.5 m (1.6 ft), indicating that the line of sight may have passed too close to the ground surface, or a temperature change during one section running of more than 5° Celsius (9° Fahrenheit), indicating an entry that may be incorrect. The program should compare collimation checks and elevation differences recomputed from the original observations to the field-computed results, flagging discrepancies for further investigation by the project office. (See fig. 5-9.)

In addition, the recomputing program may compute the total curvature correction for the stadia distance imbalance for each section running. When the necessary observations are available, it should compute total scale and refraction corrections as well. A scale correction may be computed for each rod reading, based on the most recent calibration of the leveling rod. A refraction correction may also be computed for each reading, using a model for atmospheric refraction and the measurement of air-temperature differential during the setup. If a temperature measurement is omitted, it may be interpolated for this purpose from records immediately preceding and following the omission. The total corrections should be stored on a record in the file of elevation differences that is created by the program. Corrections should not be applied to the elevation differences until a corrected abstract is computed as described in section 5.5.2.

Finally, the recomputing program should provide a section-by-section listing of the observations, including error flags. Examine the flagged lines of data to determine corrections that must be made to the observation file. Only errors and omissions for which backup records exist may be corrected. For example, if a single rod reading causes a setup to fail to satisfy the reading check, it may be changed only to match the reading shown on the backup printout of the original observations. If it already matches the printout, the reading may not be altered; the record must be flagged as rejected.

After correcting observation records, rerun the recomputing program until all correctable errors are removed and indicate this on the status sheet. Be sure the heading of the file is correct. To further check the data, before the leveling unit advances a great deal farther along the line, compute and check a field abstract. (See sec. 5.4.2.)

Recomputing handwritten observations. When observations are handwritten, use a desk calculator with a printer to recompute reading checks and elevation dif-

ferences directly from the recording forms. If there is disagreement between a difference computed in the office and that in the field, check the observations on the calculator printout against those on the recording form to verify that no blunders were made when recomputing. Explain corrections directly on the recording forms. Obviously, the observations themselves must not be "corrected." Should the observations in a setup fail to satisfy the tolerances specified in project instructions, reject the record.

Rejecting section runnings. A section running must be rejected if it contains a blunder, that is, if it includes observations that do not satisfy either the tolerances or the procedural requirements specified in the project instructions. Most blunders are detected and flagged as rejected during leveling, such as observations that fail to satisfy the reading check, movement of a turning point that is reported to the unit chief, or a running that is incomplete.

Setups that do not satisfy tolerances should be flagged as rejected when observations are recomputed. If a section running includes one or more rejected setups, or setups that are missing or out of order, reject the entire running. The recomputing program should do this automatically.

Sometimes the project office discovers a procedural error or equipment deficiency after the leveling has been completed. In such a case, flag the affected runnings as rejected, explaining the circumstances on the recording forms of handwritten data or on a comment record in the observation file of computer-recorded data.

Rejected sections must be releveled until project requirements are satisfied.

5.4.2 Checking the Field Abstract

The preparation of a handwritten abstract by the leveling unit is explained in section 3.8.3. As pages of abstracts are received, store them in line order in the notebook of recording forms or printouts for each observation file. If observations are recorded with a computer and automatically recomputed, the handwritten abstract serves as a backup record that may be discarded after processing is complete. If observations are not automatically recomputed, the handwritten abstract itself must be recomputed and checked. In either case, a field abstract must be computed automatically from the file of elevation differences for the line. Maintain a status sheet while computing and checking the abstract. (See fig. 5-11).

Creating the elevation difference file. To be included in the National Geodetic Vertical Network, the results for each section (records *40* through *43*) must be entered in the required format into a computer file of elevation differences for the entire line. If an observation file is already available in the computer, the recomputing program should create the difference file. If observations are handwritten or cannot automatically be formatted, key the results from the original recording forms (not the field abstract) onto magnetic tape or other media. Transmit the data to a computer file.

Label the elevation-difference file with the line number (or accession number), the letters "HGZ", and the number of the observation file to which it corresponds. For example, "L35.HGZF1" corresponds to the observation file L35.HGF1. Before computing an abstract, merge the elevation-difference files for the entire line, into one file, labeled with the letters "HGZFF". For example, files L35.HGZF1 and L35.HGZF2 are merged to create a file labeled "L35.HGZFF". If only one difference file is necessary for the line, label it with the letters "HGZFF".

Computing the abstract. Using the automated elevation-difference file and the description file for the line, run a program to automatically compute and print an abstract. Enter the following preliminary information: order and class of the survey, survey-point serial number and elevation of the beginning control point, and survey-point serial number of the ending control point.

The beginning point is normally one of three junction points, preferably one with a published elevation. Assign the same beginning point and elevation to every line that begins at the junction during the project. The other two points may or may not appear as a spur on the abstract, depending on the order in which they were leveled.

For a line that connects to the National Geodetic Vertical Network, obtain the adjusted elevation of the beginning point from the most recently published description. If the point is new to the national network, temporarily assign to it an elevation of 0.00000 m when computing the abstract. As soon as a connection is made to the network, compute a field elevation for the beginning point by subtracting the preliminary elevation computed for the connecting point from the adjusted elevation published for it.

Example: A line begins at the junction point M 245, for which no adjusted elevation has been published. After six sections of leveling have been completed, a connection is made to the network at bench mark J 11, which has a published, adjusted elevation of +3.5132 m. Using 0.00000 m as the elevation for M 245, the computed elevation for J 11 is -1.26418 m. The adjusted elevation minus the computed elevation equals +4.77738 m. This value is then assigned as the field elevation for M 245. Should another line begin on M 245 during the same project, assign the same field elevation to M 245.

If the control-point stampings recorded by the leveling unit are available in the elevation difference file, the abstracting program should compare them to the description file by matching survey-point serial numbers and flagging any resulting discrepancies. The program should, as described in section 3.8.3, assign designations to the control points, sort all properly identified section runnings, check multiple runnings of a single section for closure, and compute a field elevation for each control point leveled. It should not compute elevations beyond the point where a necessary running is rejected or omitted. This occurs in single-run leveling at the

first section that has not been satisfactorily leveled. In double-run leveling it occurs at the first section that has not been satisfactorily leveled in both the forward and backward directions and closed. The program should, however, continue to sort and check any remaining runnings in the file. Finally, it should compare leveling distances to the positions given in the description file for the control points, shown in figure 5-7.

The program should provide a printout of the abstract similar in form to the handwritten abstract (fig. 5-12). It should flag runnings that are rejected because of misclosure with the letter "R", and list other errors at the end of the printout.

Checking the computer-produced abstract. Examine the abstract printout to detect errors in the elevation-difference and description files and to determine which sections, if any, must be relevelled to improve the quality of the data. Check first for incorrect survey-point serial numbers, as explained here. Then investigate and resolve other errors listed on the printout. Assign releveling as necessary to close rejected sections and resolve discrepancies.

Incorrect survey-point serial numbers may cause inappropriate loops, spurs, misclosures, and running directions to appear in the abstract. Not all such errors are noticeable (fig. 5-13). Investigate suspicious cases by comparing the stampings entered on the original observation records, for every section involved, with the stampings in the description file. If the stampings do not agree, find the descriptions for the points that correspond to the stampings given in the observation records. Correct the serial numbers on each record to agree with the ones assigned in the descriptions. Then correct the observation and elevation difference files before computing a new abstract.

If the abstracting program makes a check between serial numbers and stampings, investigate the discrepancies listed. Each discrepancy indicates the presence of an erroneous stamping in either the leveling or the descriptive data, or an erroneous serial number in the leveling data. First, check for and correct format errors in the stampings. If no such errors are found, resolve the discrepancy as described previously, referring to the original observation records.

If a suspected error in the serial numbers cannot be confidently resolved by an examination of the original records, relevel to close the sections involved, carefully verifying the identity of each control point. If points misidentified in the original records can be identified by closure of original runnings with the check leveling, correct the records, explain the circumstances, and retain the original runnings in the data files.

Checking the handwritten abstract. Compare the handwritten field abstract to the recomputed and checked observation records. After correcting elevation differences that were copied or computed incorrectly, systematically proofread and recompute the abstract. Check spurs with especial care.

--*-- FIELD ABSTRACT --*--

19820121-19820318 *ZV* HGZ L24680 11 4.0 MM ORDER 1 CLASS 2 PAGE
 SOUTHERN LOUISIANA GEOTHERMAL DEVELOPMENT PROJECT
 RACELAND TO GRAND ISLE TIDE STATION

| FROM | TO | START | F/B | DIST TOTAL (KM) | ELEV DIFF (M) | -(F+B) TOTAL (MM) | MEAN DIFF FLD ELEV (M) |
|-------------------|----|---------|-----|-----------------------|------------------|-------------------------|------------------------------|
| 1862 D 192 | | | | | | | 2.34300 |
| 1862 D 192 | | 1291453 | B | 0.90 | 1.13905 | -0.78 | -1.13866 |
| 1861 Y 358 | | 1291530 | F | 0.90 | -1.13827 | | |
| | | | | 0.90 | | -0.78 | 1.20434 |
| 1861 Y 358 | | 1291240 | F | 2.10 | 0.23885 | 0.18 | 0.23894 |
| 1860 Y 191 | | 1291348 | B | 2.10 | -0.23903 | | |
| | | | | 3.00 | | -0.60 | 1.44328 |
| 1860 Y 191 | | 1291036 | B | 1.34 | 0.64082 | 2.26 | -0.64195 |
| 1859 O 8 | | 1291135 | F | 1.34 | -0.64308 | | |
| | | | | 4.34 | | 1.66 | 0.80133 |
| 1859 O 8 | | 1290828 | F | 1.63 | 0.95712 | 0.36 | 0.95730 |
| 1803 Y 298 | | 1290936 | B | 1.63 | -0.95748 | | |
| | | | | 5.97 | | 2.02 | 1.75863 |
| 1803 Y 298 | | 1290738 | F | 0.55 | -1.18807 | 1.02 | -1.18756 |
| 1863 X 298 | | 1290758 | B | 0.55 | 1.18705 | | |
| | | SL 1 | | 6.52 | | 3.04 | 0.57107 |
| 1803 Y 298 | | 1210900 | F | 0.10 | -0.73280 | -0.27 | -0.73294 |
| 1802 J 165 | | 1211058 | B | 0.10 | 0.73307 | | |
| | | SL 1 | | 6.07 | | 1.75 | 1.02570 |
| 1802 J 165 | | 1210907 | F | 1.79 | 0.72312 | 1.03 | 0.72363 |
| 1801 C 192 | | 1211010 | B | 1.79 | -0.72415 | | |
| | | SL 1 | | 7.86 | | 2.78 | 1.74933 |
| 1803 Y 298 | | 1211120 | F | 1.50 | 0.02728 | 1.92 | 0.02824 |
| 1804 A 358 | | 1220933 | B | 1.50 | -0.02920 | | |
| | | | | 7.47 | | 3.94 | 1.78687 |
| 1804 A 358 | | 1211208 | F | 1.79 | 2.26067 | 0.30 | 2.26082 |
| 1806 TT 25 L USGS | | 1211313 | B | 1.79 | -2.26097 | | |
| | | | | 9.26 | | 4.24 | 4.04769 |
| 1806 TT 25 L USGS | | 1221015 | F | 0.24 | -0.08483 | 0.18 | -0.08474 |
| 1805 A 220 | | 1221028 | B | 0.24 | 0.08465 | | |
| | | SL 1 | | 9.50 | | 4.42 | 3.96295 |
| 1806 TT 25 L USGS | | 1221036 | F | 0.05 | -0.44957 | -0.50 | -0.44982 |
| 1807 B 358 | | 1221043 | B | 0.05 | 0.45007 | | |
| | | | | 9.31 | | 3.74 | 3.59787 |
| 1807 B 358 | | 1221048 | F | 1.43 | -1.13747 | 2.25 | -1.13634 |
| 1808 B 220 | | 1270840 | B | 1.42 | 1.13522 | | |
| | | | | 10.73 | | 5.99 | 2.46152 |

Figure 5-12.—Sample of computer-produced field abstract.

DOUBLE-RUN LEVELING

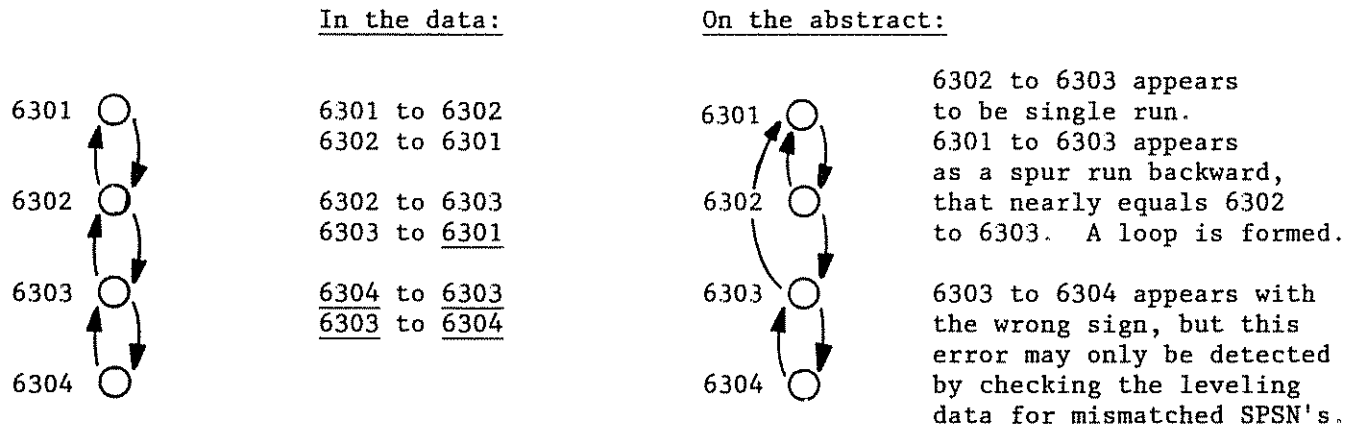

SINGLE-RUN LEVELING

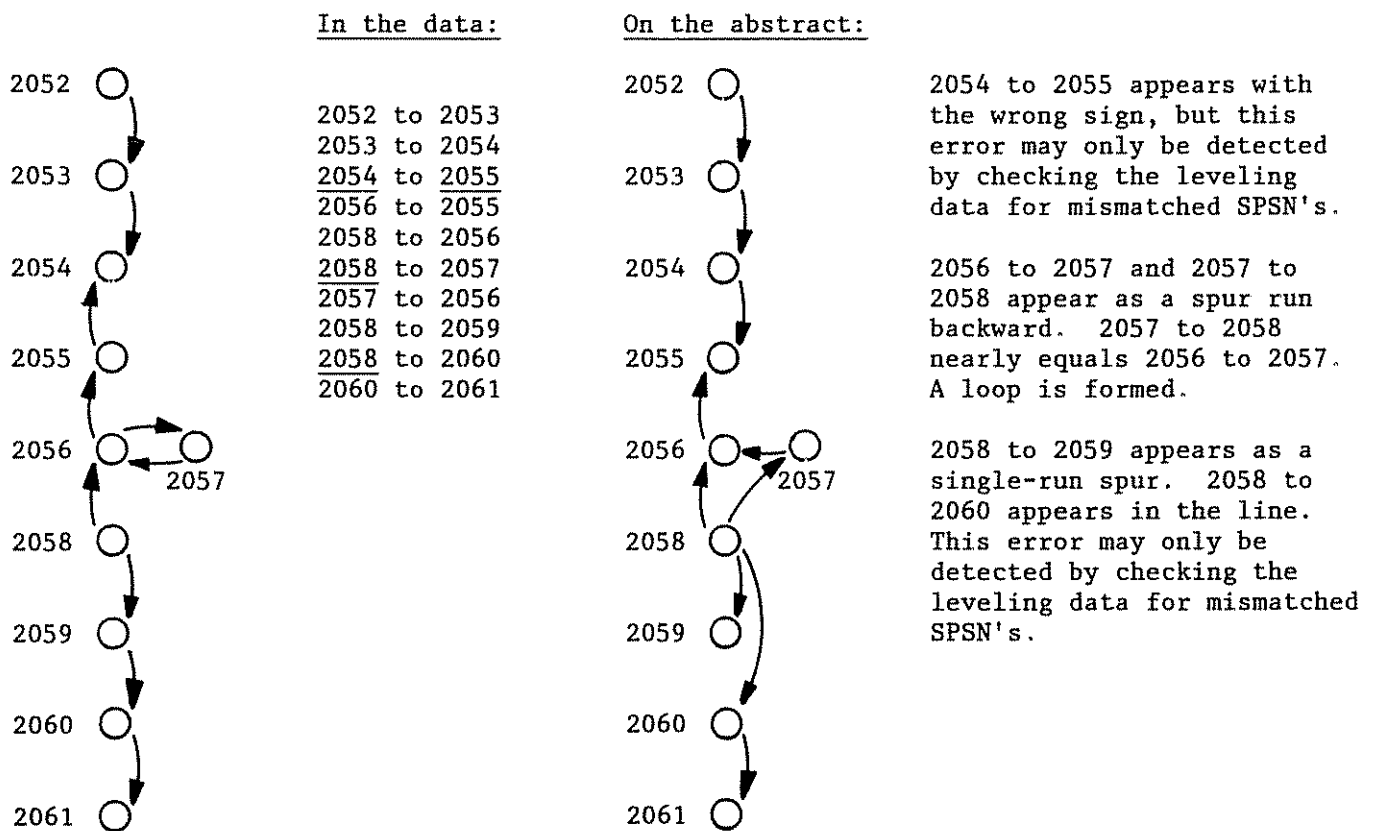

Figure 5-13.—Samples of incorrect survey-point serial numbers. Mismatched survey-point serial numbers are underlined.

When leveling results are keyed and transmitted into an elevation-difference file, typographical errors may exist in the file. To check for these errors, compare the elevations that appear on the computer-produced abstract to those on the handwritten ab-

stract. Refer to the original recording forms to resolve any discrepancies. Correct both the difference file and the handwritten abstract, rerunning the abstracting program until no discrepancies are found between them.

Creating the vertical observation data set. Either by means of the abstracting program or by keying elevations directly from the handwritten abstract, create the field abstract records (*30* lines) in the format required by NGS. These abstracts, merged with the elevation-difference file, form the "vertical observation data set" for the line. Label it with the line number (or accession number) and the letters "HGZAB". (For example, "L35.HGZAB" or "L24038-HGZAB".)

5.4.3 Preliminary Analysis

The field elevations for a line of leveling must be checked to determine if any blunders or inconsistencies remain in the data set. The new data should be compared to data from previous surveys and to data from other lines of the project. These tasks, termed "preliminary analysis," must be performed in a timely manner, so any necessary releveling may be conducted before the leveling unit has progressed to another line.

Comparing new and old elevation differences. After the abstract has been computed and checked, compare the elevation differences between each pair of recovered control points to the differences from the most recent, previous survey along the same route. This check is normally made by comparing the new field elevations to the elevations for the same points from an unadjusted abstract for the previous survey. It may be performed by means of a computer program if results from the previous survey are stored in the National Geodetic Survey data base and may be accessed by the project office. Otherwise it must be performed as described next. If an unadjusted abstract is not available, use published elevations for the points.

Prepare a table, as shown in figure 5-14, with columns for control point designations, distances along the line, new field elevations (enter the accession or line number and year of the new survey), old elevations (enter the accession number and year of the old survey), and new-minus-old values. If the new leveling applies to more than one previous survey, prepare columns for the old elevations and the new-minus-old values for each additional survey. From the field abstract for the new survey, enter the designation, distance, and elevation for each recovered control point. Then, from the abstract for each old survey, enter the corresponding elevations.

Since the new elevation for the beginning point is rarely the same as the old elevation for the same point, the difference between them will be included in the new-minus-old difference computed for every point that follows. To remove the difference, a constant must be added to each new-minus-old difference. Compute the constant, C_1 , by subtracting the new elevation for the beginning point from the old:

$$C_1 = \text{old beginning elevation} - \text{new beginning elevation.}$$

Compare the new and old elevations by subtracting the old from the new and adding the constant:

$$\begin{aligned} \text{New-minus-old value} &= \text{new elevation} \\ &\quad - \text{old elevation} + C_1. \end{aligned}$$

To compare the new survey with additional previous surveys, compute and add to each new-minus-old difference a constant that refers the comparison back to the beginning point. For example, at the first point common to two previous surveys, compute the constant for the second, C_2 , by subtracting the first elevation of the point from the second and adding the first constant:

$$C_2 = \text{second old elevation} - \text{first old elevation} + C_1.$$

Then compute the new-minus-old values as before, adding C_2 instead of C_1 . If two previous surveys have no points in common, establish a new beginning point and compute an entirely new constant for the second survey. In addition, prepare a column of the published elevations for the recovered points in the new survey that connect the two previous surveys. To make possible a check of the leveling between these points, compute new-minus-old values using the published elevations.

After computing the new-minus-old values, and carefully checking them, examine the results to find potential blunders in the leveling. If the leveling procedures and the environment were such that no accumulations of systematic error occurred during the surveys and no changes in topography occurred between them, the values would fluctuate randomly about zero and well within the tolerances for geodetic leveling. A blunder in the leveling during either survey would reveal itself between two control points as a jump (exceeding the tolerance). Misidentification of a point during either survey (or significant movement of a point) would reveal itself as a spike, which is a jump exceeding the tolerance followed immediately by another jump, bringing the total back within the tolerance. (See fig. 5-15.)

Since small amounts of systematic error may accumulate and since topographic changes occur between surveys in many parts of the continent, the new-minus-old values do not usually fluctuate randomly about zero. A difference in the accumulation of systematic error during the surveys typically reveals itself as a gradual trend toward or away from zero. The trend may be readily predictable when it is solely a function of leveling distance. It may be less so when it is a function of both distance and elevation change, perhaps mimicking the topography. Actual topographic changes between the surveys may appear as either trends or jumps and, depending on their magnitude, may not be distinguishable from errors in the leveling.

Look for jumps and spikes that do not conform to the trends. In general, the new-minus-old values should not change from one point to the next by more than the accepted tolerance for agreement between section

NEW-MINUS-OLD COMPARISONS

EXAMPLE

LINE L24448

| Control Point | Distance (km) | L 24448 1979 | L 20229 1965 | N-O+C ₁ | L 656 1933 | N-O+C ₂ | L 20669 1966 | N-O+C ₃ |
|--------------------|---------------|-----------------|-----------------|--------------------|---------------|--------------------|-----------------|--------------------|
| | | | | $C_1 = 0.0000$ | | $C_2 = 0.1734$ | | $C_3 = 0.0267$ |
| L 231 | 0.00 | 5.47510 | 5.4751 | 0.0000 | | | | |
| K 231 |) 0.09 | 2.13644 | 2.1394 | -0.0030 | | | | |
| J 231 | 0.59 | 8.06250 | 8.0641 | -0.0016 | | | | |
| Q 22 | 59.58 | 8.73215 | | | 8.5588 | 0.0000 | | |
| R 22 | 60.24 | 9.54412 | | | 9.4817 | -0.1109 | | |
| A 23 | 86.83 | 10.02366 | | | 9.7934 | 0.0569 | | |
| R 23 | 140.21 | 25.93518 | | | 25.8883 | -0.1265 | | |
| ARCADIA | 153.35 | 19.51631 | | | 19.4364 | -0.0934 | | |
| X 23 |) 164.40 | 18.67893 | | | 18.6016 | -0.0960 | | |
| A 24 | 172.17 | 12.11115 | | | 12.03853 | -0.1007 | | |
| W 260 |) 186.08 | 8.11921 | | | | | 8.17961 | -0.0871 |
| X 260 |) 191.76 | 3.95504 | | | | | 4.01583 | -0.0875 |
| R 260 | 191.97 | 4.12528 | | | | | 4.18551 | -0.0869 |
| N 260 | 194.54 | 2.29061 | | | | | 2.34633 | -0.0824 |
| V 260 | 198.26 | 2.89240 | | | | | 2.94812 | -0.0824 |
| CLEVELAND | 199.88 | 2.64930 | | | | | 2.70118 | -0.0785 |
| CLEVELAND AZ MK | 200.47 | 1.91607 | | | | | 1.96779 | -0.0784 |
| L 260 | 202.00 | 1.30915 | | | | | 1.36234 | -0.0798 |
| H 260 | 202.59 | 2.08215 | | | | | 2.13642 | -0.0809 |
| G 260 | 204.10 | 2.06877 | | | | | 2.12148 | -0.0794 |
| K 38 |) 205.56 | 1.68352 | | | 1.58166 | -0.0715 | 1.72835 | -0.0715 |
| L 38 RESET 1961 | 205.85 | 2.87545 | | | | | 2.92881 | -0.0800 |
| Q 38 | 206.60 | 3.87255 | | | 3.75955 | -0.0604 | 3.92092 | -0.0750 |
| COLLIER | 206.62 | 3.76595 | | | | | 3.81455 | -0.0753 |
| | | | | | | | | |
| | | | | | | | | |

Figure 5-14.—Example of comparisons between new-minus-old observed elevations.

runnings, computed for whichever survey is of lower order and class. However, if most successive pairs of points exhibit relative change or "noise," this tolerance may be unreasonably restrictive. Experience and good judgment should be applied to spot inconsistencies. Since a jump may herald a set of values that has been computed incorrectly and a spike may represent a single point that has been computed incorrectly, double-check the computations before investigating further.

Do not assume that a jump, inconsistent with the trends of the preceding or following sections, represents a topographic change. If the new leveling is single run, check it by releveling to close the section (or sections) that comprises the jump. If the leveling is double run, check the observation records for reversed identification of

the control points or for leveling rods observed consistently in reversed order. Reversed identification is likely if the elevation difference for a section of new leveling is opposite in sign and nearly equal in magnitude to one-half of the amount of the jump. Relevel to verify the identity of such a section. If no error is found, note the jump in the project report.

Since a spike results if a control point moves significantly between the surveys, check the description for the point to see if the mark setter noted any damage to, or apparent relocation of, the monument. If new single-run sections comprise the spike, relevel them to close the leveling line. If the leveling is double run, check that the point is correctly identified in the observation records; sometimes a nearby bench mark may have been

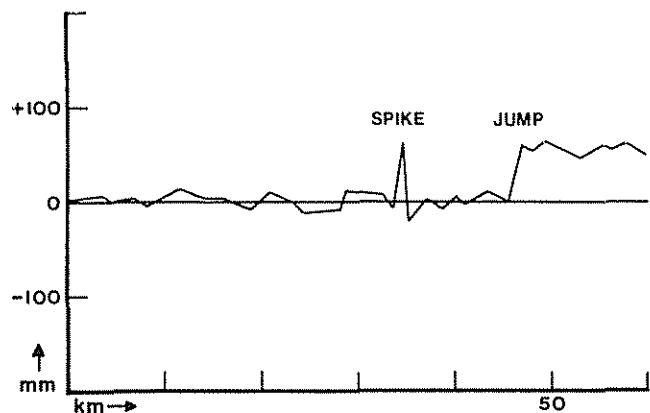

Figure 5-15.—Sample plot of new-minus-old values for observed elevations.

leveled instead of the point originally assigned. In this case, prepare a description for the newly recovered point and level a spur to the assigned point.

Checking loops. As portions of new lines are completed that connect to previous or concurrent surveys, check the closure errors of the circuits or “loops” thus formed. Compute closure error by totaling the elevation differences around a loop, beginning and ending at the same control point. The result should not differ from zero by more than the loop tolerance for the leveling methods employed in the surveys.

First, make a sketch of the loop, labeling each segment of line or “link” with its order and class, accession number, and year. From the field abstracts and/or summary sheets, determine the connecting points and label them. Where a tie is established, choose the connecting point that appears least likely to have moved since the previous survey. Write the unadjusted elevation for each connecting point for each survey in which it is included. (An example is given in fig. 5-16.)

Second, compute the elevation difference for each link. From the elevation at the end of the link, subtract the elevation at the beginning. Write the result over an “arrow” indicating the direction in which the link difference was computed. Write the leveling distance under the arrow.

Finally, working clockwise, sum the elevation differences. If a link was leveled counterclockwise in the loop, change the sign of the elevation difference before adding it to the total. Write the closure error in the center of the loop. Compute the total distance around the loop and write it under the closure error.

To compute the loop tolerance, total the leveling distances separately for each order and class of survey. If the entire loop consists of leveling of the same order and class, the tolerance is computed, as described in fig. 3-9 (sec. 3.1.3). If more than one order and class are included, compute a tolerance for each using the appropriate distances. Then, square the tolerances, sum them, and take the square root of the result:

$$\text{Tolerance} = \pm [(T_1^2 \times \sqrt{K_1}) + (T_2^2 \times \sqrt{K_2}) + (T_3^2 \times \sqrt{K_3}) + \dots]^{1/2} \text{ mm.}$$

Example: The loop in figure 5-16 includes four links, two of first-order, class I leveling, one of first-order, class II leveling, and one of second-order, class I leveling. The total distances are 208 km, 52 km, and 110 km, respectively. The tolerance for the closure error is:

$$\text{Tolerance} = \pm [(4^2 \times \sqrt{208}) + (5^2 \times \sqrt{52}) + (6^2 \times \sqrt{110})]^{1/2} = \pm 92.7 \text{ mm.}$$

Compare the misclosure error to the loop tolerance. When a loop includes leveling from a single season or epoch, failure to close within the tolerance is probably the result of one or more blunders in the leveling. First, double-check the computation of the closure. Then, check and recompute the ties at junctions. Do not use as connecting points monuments that appear to have moved between the levelings. Ensure that the junction points have been identified correctly in the observation records.

If the loop still fails to close within the tolerance, investigate further. Try to isolate the links where blunders might have occurred. For example, look at the closure error of a large loop encompassing the one in question, such as ABCD in figure 5-17. The sum of the closure errors of ABD and BCD is equal to the closure error of ABCD. If ABD and BCD are not within tolerance, but ABCD is, the blunder is most probably in link BD. If ABD closes but BCD does not, links BC or CD should be examined.

Reexamine the new-minus-old values to find jumps. Check the field abstracts for an elevation difference in one section that is opposite in sign to and about one-half the magnitude of the closure error. If the leveling is single run, relevel to close doubtful sections. Check the identification of double-run sections. Consult the project manager at headquarters before undertaking any extensive releveling to close a loop.

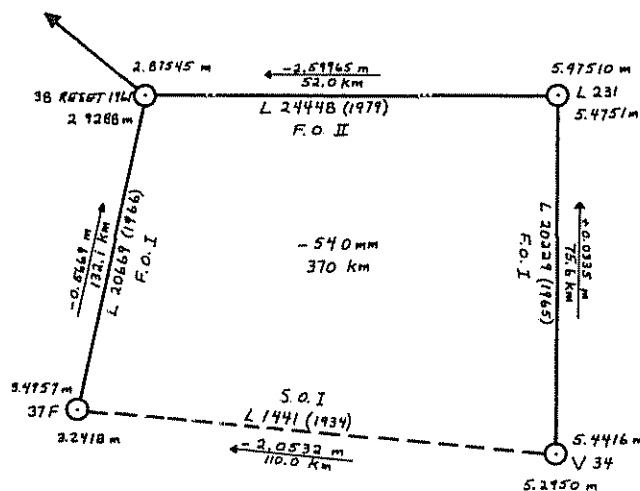

Figure 5-16.—Sample sketch for checking a loop.

When a loop includes leveling from more than one epoch, failure to close within the tolerance may or may not be the result of blunders in the new leveling. If a link of new leveling begins in an area of crustal subsidence and ends in an area of relative stability, the loop formed with leveling from a previous epoch cannot be evaluated without knowledge of the rate of subsidence, even though ties are established to the previous surveys at each end of the link. Similarly, if the connection between new and previous leveling consists only of a single point, potential movement or damage to the point itself may prevent confident evaluation of the loop. Nevertheless, a large misclosure error should be investigated, as described previously, particularly if it is inconsistent with the geology of the area.

5.4.4 Statistics

The final step in processing leveling data at the project office is to obtain a statistical summary of the work accomplished for each line. The summaries permit final checks of the validity of the data and are the source of statistics for the entire project.

Some statistical information, such as the standard error of the reading checks attributed to each observer or instrument, may be obtained only when the observation records are recomputed. Most information, however, may be obtained by computing statistics from the vertical observation and descriptive data sets.

When possible, run a program to compute from the leveling file (HGZAB) such statistics as total progress, progress along the main line, progress along spurs, double-run progress, single-run progress, percent of progress requiring one or more reruns, total distance leveled, distance leveled as reruns, percent of leveling rejected, number of sections, number of setups, number of observing hours and days, average sighting distance and time per setup, and average leveling distance per hour and day. The program should provide a breakdown of the hourly and daily statistics for each combination of observer, instrument, and rods in the line, listing the appropriate initials and serial numbers. Check them to verify once more the identification records.

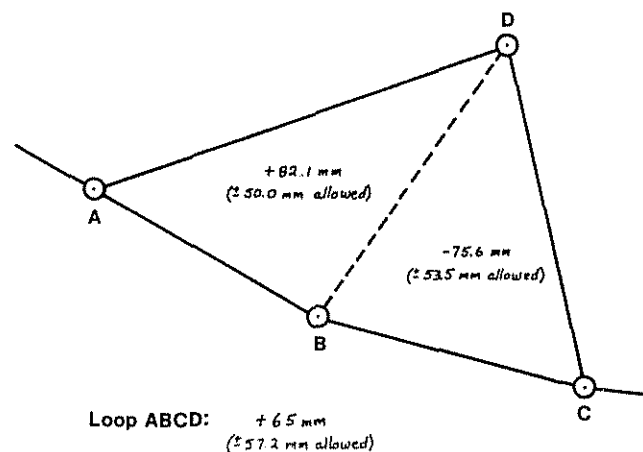

Figure 5-17.—Combining loops.

From the description file (HAFF), the program should compute the total number of control points and the totals of points newly set, recovered in good condition, recovered in poor condition, and recovered new to the network. Also, it should provide breakdowns by type of the numbers of newly set and recovered points, computing the percentages of monuments of each quality rating. (See sec. 2.4.4.) For a file of descriptions of points not leveled, the program should compute the numbers of points recovered in good condition, recovered in poor condition, destroyed, and not recovered, including a breakdown by type and quality rating.

Check that the total number of leveling sections equals the total number of control points, minus one. If the number of sections is too small, one or more points may have been skipped by the leveling. If the number is too large, one or more loops, correct or incorrect, may exist in the line. Investigate such discrepancies thoroughly and correct them, if possible. Note loops that are correctly included in a line on a comment record in the leveling file.

5.5 Verification and Adjustment

When data from a vertical survey are received by the National Geodetic Survey, they are checked for completeness and, if acceptable, verified and stored in the appropriate computer files of the National Geodetic Survey data base. The data are corrected for known systematic errors. The survey is then adjusted, and elevations are published as part of the National Geodetic Vertical Network. These activities are discussed next, to provide an overview of the process by which geodetic elevations are computed.

5.5.1 Quality Control Review

Before a survey may be incorporated into the national network, the survey must meet strict standards of completeness, consistency, and accuracy. The quality control review is designed to detect oversights, misunderstandings, and deviations from the specifications governing inclusion of data in the network. It is conducted in two steps, preaccessioning and verification.

Preaccessioning. To be accepted by the National Geodetic Survey, a survey must be documented completely. The required records are listed in section 5.2.4. As soon as a survey is received, it is checked to ensure that all required records are present, complete, and properly formatted.

After all records are obtained, an accession number is assigned (if it had not previously been assigned in the project instructions.) (See sec. 5.2.3.) The number permanently identifies the survey for purposes of storage and retrieval. Then, documents are placed in archives, and computer files are transferred to a working file for further processing.

Verification. The Vertical Network Division checks each line of leveling received for compliance with the specifications given in this manual and in the project instructions. Data files are checked for consistency, completeness, and compliance.

During this process new control points are assigned archival cross-reference numbers. Discrepancies are resolved by referring to the original records; questionable data that cannot be corrected from original records are rejected. Occasionally, additional leveling may be required to verify questionable data. Acceptable description records are transferred directly into the data base for publication. Acceptable leveling records are corrected for systematic error and cataloged and stored in the data base for eventual adjustment.

The verifier then prepares a report summarizing the results of the quality control review and states the extent to which the survey has been accepted for inclusion in the data base. Specific discrepancies and deficiencies in the data files and the original records are noted. A copy of the report is forwarded to the contributor to aid in the conduct of future surveys.

5.5.2 Computing Corrections

In a survey network, numerous lines are leveled with various instrumental systems and under varying environmental conditions. Before the lines are adjusted, the data must be "normalized" or "reduced" to provide elevation differences that refer to a standard set of conditions, under which the probable magnitude of random error may be estimated. All known instrumental and environmental effects, causing systematic error to accumulate in one section relative to another, must be removed from the measured elevation differences.

Geodetic leveling, as explained in section 3.1.2, limits systematic error with symmetrical procedures. However, to obtain the most accurate results, particularly for surveys covering large areas or areas of dramatic elevation change, certain types of systematic error may be removed sufficiently only by applying corrections. These include the effects of instrument collimation error, scale imperfections, atmospheric refraction, curvature of the reference surface, tidal accelerations on the gravity field, and variations inherent in the gravity field.

A detailed explanation of the corrections applied by NGS to precise leveling observations appears in *NOAA Technical Memorandum NOS NGS 34, Corrections applied by the National Geodetic Survey to precise leveling observations* (Balazs and Young 1982).

Typically, the equation describing an error effect is derived mathematically and tested by experiment. To make the correction worthwhile, the effect must be computed with sufficient accuracy relative to its magnitude. The parameters necessary to compute the error are measured routinely during leveling. To remove it from the leveling results, the error is subtracted. Thus, the correction that is added to the elevation difference of a setup or section is always equal in magnitude and opposite in sign to the effect itself.

The corrections discussed here are applied routinely by the National Geodetic Survey when preparing an abstract of leveling (PHASE 1) for adjustment. Unless otherwise specified, all corrections are computed in metric units. Typical correction values are shown in figure 5-18.

Collimation error. If the instrument provides a line of sight sufficiently close to the horizontal, as explained in section 3.3.3, and if setups are balanced within tolerance, a correction for collimation error need not be applied. However, for the most precise results, particularly if leveling extends over a large area and section imbalances are large and consistently positive or negative, the correction should be applied. It should also be applied when either the collimation factor or section imbalance exceeds tolerance (specified in fig. 3-9 of sec. 3.1.3).

To correct for the effect of collimation error, the collimation factor must be measured with sufficient accuracy during the collimation check. The collimation factor, C , measured at the most recent, previous, collimation check, is multiplied by the accumulated section imbalance, $\Sigma\Delta s$, to compute the effect. The correction, opposite in sign, is added to the elevation difference for the section:

$$\text{Collimation correction} = -C \times \Sigma\Delta s.$$

The correction could be applied to each setup, but nothing is gained by this. Since the factor is assumed to be constant throughout the section, the sum of the setup corrections equals the correction given above.

Scale imperfections. Imperfections in the scales on the leveling rods create error that is a function of elevation difference and, thus, cannot be limited by restrictions placed on sighting distance. Two corrections must be applied to standardize the observed elevation differences with respect to the National Standard of Length. One, the length-excess correction, removes the effect of differences between the graduations observed at a standard temperature and their calibrated values at the same temperature. The second, the thermal-expansion correction, removes the effect of variations in scale temperature.

The length-excess correction is most accurately computed for each setup when observations are recomputed as described in section 5.4.1. The most recent, previous calibrated values of the graduations at a standard temperature are required. First, the graduation component of each scale reading is converted to its corresponding calibrated value and added to the micrometer readings also converted to meters. From the scale readings thus corrected, the elevation differences for each setup are recomputed and totaled for the section. The correction in this case, then, is the difference between the corrected and uncorrected elevation differences.

If calibrated values for every graduation are not available, values for index error and length excess from the most recent, four-interval calibration (see sec. 3.4.2)

| RELEVELING | | RUN DATE: 21 APR 82 | | TIME: 09:42 | | PAGE 1 | | HGZ L24680 PART 11 | | 4.0 MM 1ST-ORDER/CLASS II | |
|---|----------|-------------------------------------|-----------|-------------|------|-------------|----------|--------------------|-------|---------------------------|--|
| SOUTHERN LOUISIANA GEOTHERMAL DEVELOPMENT PROJECT | | RACELAND TO GRAND ISLE TIDE STATION | | 21 JAN 1982 | | 18 MAR 1982 | | | | | |
| INST/RODS | OBS DIFF | LEVEL | ROD | TEMP | MEAN | ASTRO | REFRAC | CORR DIFF | DIST | | |
| DESIGNATION | | CORR | CORR | CORR | TEMP | CORR | CORR | MEAN DIFF | MIN | | |
| 1/ 1 B | 1.13905 | 0.00001 | 0.00002* | -0.00000 | 22.5 | 0.00001 | 0.00000 | 1.139088 | 0.903 | | |
| 1/ 1 F | -1.13827 | 0.00000 | -0.00003* | 0.00000 | 21.4 | -0.00000 | -0.00000 | -1.138303 | 0.904 | | |
| D 192 | | TO Y 358 | | | | | | -1.138696 | 0.903 | | |
| 1/ 1 F | 0.23885 | -0.00001 | -0.00023* | -0.00000 | 22.8 | 0.00011 | 0.00001 | 0.238719 | 2.102 | | |
| 1/ 1 B | -0.23903 | 0.00000 | -0.00022* | 0.00000 | 23.1 | 0.00007 | 0.00000 | -0.239171 | 2.098 | | |
| Y 358 | | TO Y 191 | | | | | | 0.238945 | 2.098 | | |
| 1/ 1 B | 0.64082 | 0.00000 | 0.00002* | -0.00000 | 22.8 | 0.00005 | -0.00002 | 0.640866 | 1.338 | | |
| 1/ 1 F | -0.64308 | 0.00000 | 0.00003* | 0.00000 | 22.8 | 0.00006 | 0.00003 | -0.642957 | 1.338 | | |
| Y 191 | | TO O 8 | | | | | | -0.641912 | 1.338 | | |
| 1/ 1 F | 0.95712 | -0.00001 | 0.00006* | -0.00001 | 18.3 | -0.00001 | 0.00000 | 0.957157 | 1.632 | | |
| 1/ 1 B | -0.95748 | -0.00000 | -0.00009* | 0.00000 | 21.4 | 0.00003 | 0.00000 | -0.957541 | 1.632 | | |
| O 8 | | TO Y 298 | | | | | | 0.957349 | 1.632 | | |
| 1/ 1 F | -1.18807 | 0.00001 | -0.00019* | 0.00001 | 15.0 | -0.00001 | -0.00004 | -1.188289 | 0.549 | | |
| 1/ 1 B | 1.18705 | -0.00001 | -0.00015* | -0.00001 | 16.1 | -0.00001 | 0.00000 | 1.186867 | 0.551 | | |
| Y 298 | | TO X 298 | | | | | | -1.187578 | 0.549 | | |
| 1/ 1 F | -0.73280 | 0.00000 | -0.00023* | 0.00000 | 19.7 | -0.00000 | -0.00001 | -0.733045 | 0.104 | | |
| 1/ 1 B | 0.73307 | 0.00000 | -0.00020* | -0.00000 | 23.9 | -0.00001 | 0.00004 | 0.732903 | 0.102 | | |
| Y 298 | | TO J 165 | | | | | | -0.732974 | 0.102 | | |
| 1/ 1 F | 0.72312 | 0.00000 | 0.00004* | -0.00000 | 20.8 | -0.00004 | 0.00010 | 0.723215 | 1.789 | | |
| 1/ 1 B | -0.72415 | 0.00000 | -0.00001* | 0.00000 | 22.8 | -0.00007 | -0.00012 | -0.724341 | 1.787 | | |
| J 165 | | TO C 192 | | | | | | 0.723778 | 1.787 | | |
| 1/ 1 F | 0.02728 | -0.00000 | 0.00002* | -0.00000 | 24.4 | 0.00009 | 0.00001 | 0.027399 | 1.500 | | |
| 1/ 1 B | -0.02920 | 0.00000 | 0.00005* | 0.00000 | 22.2 | 0.00005 | 0.00000 | -0.029091 | 1.500 | | |
| Y 298 | | TO A 358 | | | | | | 0.028245 | 1.500 | | |
| 1/ 1 F | 2.26067 | 0.00000 | 0.00009* | 0.00000 | 25.0 | 0.00009 | 0.00013 | 2.260980 | 1.792 | | |
| 1/ 1 B | -2.26097 | 0.00000 | -0.00006* | -0.00000 | 25.3 | 0.00008 | -0.00005 | -2.261014 | 1.795 | | |
| A 358 | | TO TT 25 L USGS | | | | | | 2.260997 | 1.792 | | |
| 1/ 1 F | -0.08483 | -0.00000 | -0.00002* | 0.00000 | 23.6 | -0.00001 | 0.00003 | -0.084829 | 0.239 | | |
| 1/ 1 B | 0.08465 | 0.00000 | 0.00003* | -0.00000 | 23.6 | -0.00001 | -0.00007 | 0.084612 | 0.239 | | |
| TT 25 L USGS | | TO A 220 | | | | | | -0.084721 | 0.239 | | |
| 1/ 1 F | -0.44957 | 0.00000 | -0.00021* | 0.00000 | 23.3 | 0.00001 | -0.00000 | -0.449775 | 0.050 | | |
| 1/ 1 B | 0.45007 | 0.00000 | -0.00014* | -0.00000 | 23.3 | 0.00001 | 0.00000 | 0.449936 | 0.050 | | |
| TT 25 L USGS | | TO B 358 | | | | | | -0.449856 | 0.050 | | |

Figure 5-18.—Sample corrections applied in phase 1 of office abstract.

must be used to compute the length-excess correction for the section. It is approximated by multiplying the observed elevation difference, ΔH , by the mean length excess of the rod pair, \bar{e} . The correction for the difference between the index errors, i , of the scales observed at the beginning and ending control points is also included:

$$\text{Length-excess correction} = \bar{e} \times \Delta H - (i_{\text{begin}} - i_{\text{end}}).$$

The correction for index error may be neglected if every section includes an even number of setups; in other words, if the same scale is observed at the beginning and ending control points.

To compute the thermal-expansion correction, leveling data must include at least a mean scale temperature for each section. In addition, the coefficients of thermal expansion from the most recent standardization of the scales must be available. The correction

is approximated from mean coefficient of thermal expansion for the rod pair, \bar{k} , the mean observed scale temperature, \bar{t} , the standardization temperature, t_s , and the elevation difference, ΔH :

$$\text{Thermal-expansion correction} = \bar{k} \times (\bar{t} - t_s) \times \Delta H.$$

Note that the sign of this correction formula is positive. This is because the values read from an "expanded" scale are *smaller* in magnitude than those read from the same scale at the standardization temperature. The magnitude of the elevation difference, obtained from the observation of "expanded" scales, must be *increased* by the correction.

Refraction. Because refraction depends on elevation difference and atmospheric conditions as well as sighting distance, the error due to refraction is only partially limited by restricting setup imbalance and sighting distance. Corrections must be applied, preferably to the

elevation difference for each setup, to reduce refraction error. They must be applied consistently to leveling data from different epochs, since the tolerances placed on sighting distance have varied significantly in the past.

Corrections for refraction are best obtained by measuring air-temperature differentials at each setup, as described in section 3.6.2. The approximate refraction correction for the setup may be computed from the mean sighting distance (instrument to rod) for the setup, \bar{s} , the observed air-temperature differential between 1.3 and 0.3 meters, Δt , and the observed elevation difference, Δh , for the setup. A formula such as Kukkamaki's is used:

$$\text{Refraction correction} = -0.00070 \times \alpha \times (s/50)^2 \times \Delta t \times \Delta h.$$

The constant, α , depends on the units of measurement; for Δh and \bar{s} in meters and Δt in degrees centigrade, $\alpha = 200$. Other models for refraction are under development.

Leveling data that do not include measured temperature differentials may be corrected by means of a similar formula, in which the temperature differentials are predicted from atmospheric data given in the leveling records, and historical climatological data for the time of day, date, and geographic position of the leveling. This correction is added to the elevation difference of each section.

Curvature. If setups are balanced and sighting distances are maintained within tolerance, the effect of curvature is so small that a correction need not be applied to leveling extending over a small area. However, as with collimation error, for the most precise results the correction should be applied over large areas.

The curvature correction is approximated from a spherical model of the Earth. It is computed for each setup from the imbalance, Δs , and the mean radius of the Earth, r :

$$\text{Curvature correction} = -\Delta s^2 / (2 \times r).$$

The total correction for the section is most efficiently computed from the sum of the sight distance imbalance for the setups.

Tidal accelerations. Since the effect of tidal accelerations on the gravity field is primarily a function of the time and route of leveling, this effect cannot be minimized by procedure. Although the effect is very small, if a survey extends over a large area, the "astronomic correction" should be applied.

The astronomic correction is computed from the date, time, and position of the section. From the date and time are computed the azimuths of the Sun and Moon, α_s and α_m , respectively, and the corresponding horizontal deflections, ϵ_s and ϵ_m of the gravity field. From the positions of the two control points are computed the length, S , and azimuth, α , of the section. Azimuths

are measured clockwise from south; therefore, the correction is positive when the ending point is north of the beginning point:

$$\text{Astronomic correction} = 0.7 \times S \times [\tan \epsilon_m \times \cos (\alpha_m - \alpha) + \tan \epsilon_s \times \cos (\alpha_s - \alpha)].$$

The factor, 0.7, is included to reduce the correction because the Earth's crust is somewhat elastic and the models by which deflections may be computed assume a rigid Earth. The deflections are computed by the National Geodetic Survey from equations developed by Longman (1959) and astronomic parameters taken from *The Astronomical Almanac* (U.S. Naval Observatory/Her Majesty's Nautical Almanac Office).

Gravity field. Since the level surfaces defined by the Earth's gravity field are not parallel, as explained in subchapter 1.3, the elevation difference measured between two control points depends on the route followed by leveling. A difference independent of the route may be obtained by converting the observed difference in orthometric height between each pair of points to the difference in potential between the level surfaces passing through them. For a section, the potential difference is the corrected elevation difference, ΔH in meters, multiplied by the mean of the measured values of gravity at the two control points, \bar{g} in kilogals. The potential difference is expressed in kilogal-meters, called geopotential units (gpu):

$$\text{Potential difference} = \bar{g} \times \Delta H.$$

The elevations obtained by totaling potential differences are designated geopotential numbers.

If gravity is not measured with sufficient accuracy to compute potential differences, a model for the gravity field must be used to compute a correction to be added to the orthometric-height difference of each section. From Helmert's international formula for normal gravity, the following "orthometric correction" has been derived. It has a function of the mean elevation, \bar{H} in meters, the mean latitude, $\bar{\phi}$, and the northward change in latitude $\Delta \bar{\phi}$, for the section. Two constants, $\alpha = 0.002644$ and $\beta = 0.000007$, are used:

$$\begin{aligned} \text{Orthometric} \\ \text{correction} = & -2\alpha \times \bar{H} \times \sin 2\bar{\phi} [1 + [\alpha - (2\beta/\alpha)] \\ & \times \cos 2\bar{\phi}] \Delta \bar{\phi}. \end{aligned}$$

The elevations obtained by totaling elevation differences corrected in this way are called normal orthometric heights.

5.5.3 Adjustment

After correcting the leveling data, abstracts of reduced elevations are computed for every line or link in the survey network. The expected value of a loop closure computed from the reduced elevation differences is zero

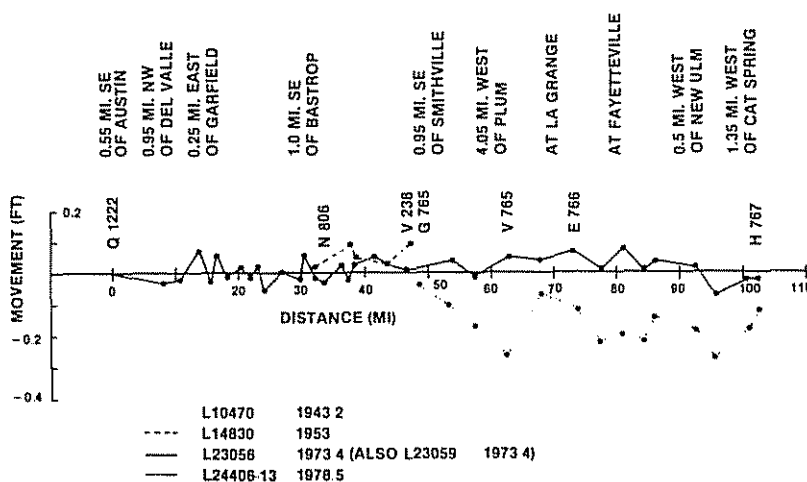

Figure 5-19.—Sample profile of a leveling line.

if all systematic errors have been removed. In other words, if one point is assigned an elevation and all other elevations are computed from it, the same elevation should be obtained for each point no matter which lines are used to compute it. However, since random error remains in the leveling data, misclosures are normally obtained. The elevation differences of the lines must be simultaneously “adjusted” to provide consistent values for the most probable elevations of the points.

Adjustments normally include a combination of new and old leveling lines which form loops with acceptable loop closures. The lines are usually “fitted” into the national network by holding “fixed” elevations of two or more widely spaced points that are common to both the points in the new adjustment and the national network. To determine the most suitable points for this purpose, comparison “profiles” are made for points common to both the new survey and previous surveys (fig. 5-19). The profiles are plots of new-minus-old values, computed from corrected elevations. From the profiles and an analysis of the geology of the area, the fixed points are selected.

In the adjustment, “most probable” corrections are computed by the method of least squares, to eliminate the closure errors of the loops. Misclosure are assumed to be the result of random error; therefore, a correction is apportioned to each line on the basis of the probable magnitude of random error included in it.

For this purpose, the elevation difference of each line is assigned a weight. The weight is based primarily on the distance over which the elevation difference was measured and the techniques and equipment employed to obtain it. Of particular importance is the degree of precision achieved when checking setups, sections, and loops. Other factors include the extent to which the data were reduced, the magnitude of the elevation changes along the line, and the times and temperatures at which observations were made. All lines of leveling are assigned an order and class based on these factors. The toler-

ances given in figure 3-9 of chapter 3, if satisfied, should yield results of the indicated order and class.

The correction for each line is apportioned among the elevation differences of the sections included in the line. Starting with one of the fixed points, the differences are totaled to obtain adjusted elevations. The adjusted elevations, expressed as normal orthometric heights (see subchapter 3.1), are stored in the data base and published in the Vertical Control Data of the National Geodetic Survey.

5.6 References

- Balazs, E. I. and Young, G. M., 1982: Corrections applied by the National Geodetic Survey to precise leveling observations. *NOAA Technical Memorandum NOS NGS 34*, National Geodetic Information Center, NOS/NOAA, Rockville, Md. 20852, 14 pp.
- Longman, I. M., 1959: Formulas for computing the tidal accelerations to the moon and the sun. *Journal for Geophysical Research* 64 (12), 2351-2355.
- National Almanac Office/Her Majesty's Nautical Almanac Office, revised annually: *The Astronomical Almanac*. Superintendent of Documents, U.S. Government Printing Office, Washington, D.C. 20402.
- Greenawalt, C. B. and Floyd, R. P., 1980: National Geodetic Survey Operations Manual. NGS Operations Division, NOAA/NOS, Rockville, Md. 20852 (unpublished manuscript).
- Pfeifer, L. and Morrison, N., 1980: *Input Formats and Specifications of the National Geodetic Survey Data Base*, volume II: Vertical control data. Federal Geodetic Control Committee. National Geodetic Information Center, NOAA/NOS, Rockville, Md. 20852, 136 pp.



APPENDIX A—LISTS OF EQUIPMENT

RECONNAISSANCE AND MARK SETTING

Mark setting truck. For routine reconnaissance and mark setting, a 1 ton, pickup truck with a utility bed is suitable. It should be fitted with waterproof lockers and boxes for storing tools, supplies, and data. In addition, it should have a cement storage box and a water tank of at least 10-gallon capacity with a hose. The rear should be painted with 6-inch, diagonal, black stripes, so the truck can be easily seen by approaching traffic.

Drilling rig. For setting class A rod marks, a truck-mounted drilling rig is necessary. The truck should be fitted for routine reconnaissance and mark setting, including additional storage space for class A rod-mark supplies and a larger, pressurized water tank. The truck must have a sufficiently heavy-duty suspension system to support the drilling rig and its associated augers, specialized tools, and large quantities of supplies.

Safety equipment

12-Volt amber safety light, mounted on top of the truck
spare fuses for the safety light
tire changing tools
tow chain
15-pound ABC-rated fire extinguisher
safety flares or reflecting triangles
flashlight
first-aid kit
packet of accident forms
6 to 8 traffic cones
2 brilliant orange safety vests
extra safety vests
2 hard hats
extra hard hats
2 prs. steel-toed work boots
2 prs. ear plugs or covers
2 prs. safety goggles or glasses
2 prs. work gloves

Tools

pipe and cable locator
rock drill w/tool kit and shipping box
rock drill supplies (oil, gasoline, funnel, filters)
drill bit
9/16-inch rod driver
tip for rod driver (make from a threaded stud and a short piece of stainless steel rod)
hydraulic crimper/cutter device with foot pump
small shovel
standard shovel
post-hole digger
2 prs. vice grips

hacksaw and blades
wheelbarrow, for mixing cement
rivet gun and rivets, for attaching witness-post signs
post driver or sledge hammer
2-pound hammer
carpenter's hammer
1/4-inch die set, for stamping designations
stamping block
30-meter tape measure with both English and metric units
100-meter tape measure with both English and metric units
compass
large clipboard for maps
clipboard for descriptions
tool kit for vehicle maintenance

Supplies

9/16-inch stainless steel rod
threaded, stainless steel studs
driving points
stainless steel caps
5-inch PVC pipe, cut in 2-foot lengths
PVC glue
mortar and cement
aluminum logo flanges
brass bench-mark disks
flagging
yellow lumber crayon ("keel")
witness posts
witness signs
notebook
black pens
strapping tape
labels
notebook covers
mailing tubes and envelopes

Additional tools and supplies for drilling rig

ball peen hammer
pipe wrenches
auger pins and hooks
grease gun
tool kit for maintenance of drilling rig
1-inch PVC pipe
3/4-inch PVC pipe and female adapters
O-rings
grease

Forms and references

project instructions
Bench Mark Description (NOAA Form 76-186)
record of designations

administrative forms (e.g., monthly reports, truck reports, travel vouchers)
NOAA Manual NOS NGS 3, Geodetic Leveling (this publication)
NOAA Manual NOS NGS 1, Geodetic Bench Marks Input Formats and Specifications of the National Geodetic Survey Data Base, volume II: Vertical control data
 operating and maintenance manuals for tools

LEVELING

Leveling truck. During conventional leveling a ruggedly constructed "carryall" truck, with standard transmission and good all-around visibility, is suitable for the transportation and storage of leveling equipment. The truck should be equipped with a roof rack on which the rod box and other storage boxes may be mounted. Side steps (for the observer's use) and rear steps (for the rodmen's use) should be mounted at a height that permits handholds on the back of the rack to be reached comfortably. The rear should be painted with 6-inch diagonal black stripes so the truck can be easily seen by approaching traffic. Inside the truck, there should be provision for storing the instrument so it will receive a minimum of shock and vibration. The unit chief should see that the truck is kept orderly and receives routine maintenance and repairs.

Safety equipment

1 12-volt, amber, strobe light, mounted on top of the truck
 spare fuses for the safety light
 jack and tire-changing tools
 tow chain
 15-pound ABC-rated fire extinguisher
 safety flares or reflecting triangles
 2 "SURVEY CREW AHEAD" warning signs
 5 brilliant orange safety vests (one per unit member)
 extra safety vests
 5 hard hats
 flashlight
 tool kit for vehicle maintenance
 first aid kit
 packet of accident forms

When controlling traffic

2 "STOP - SLOW" signs for flagmen
 2 portable, two-way radios
 2 or more orange flags
 additional warning signs

Technical equipment and supplies

leveling instrument, in a protective case
 instrument tool kit (with adjusting pins, lens brush, small wrench, small screwdriver, cleaning cloth, and manufacturer's manual for the instrument)
 tripod (height compatible with the instrument and the observer)

thermometer, for reading air temperature
 digital temperature display and 2 shielded sensors, mounted on tripod, for measuring air temperature differentials
 spare batteries and sensor for temperature equipment
 black pen with waterproof ink
 clipboard or notebook, for recording forms
 lightweight collapsible, stool
 2 leveling rods, in padded storage box
 2 turning-pin guides ("flippers"), attached to the rods
 2 pairs of top-mounted, brace poles for the rods
 plumb bob
 1-meter Invar scale in a protective case
 pair of calibrated 20-millimeter spacers ("plugs")
 carpenter's level
 3 turning pins with driving caps
 3 plastic-headed mallets
 spare plastic replacement heads for mallets
 3 heavyweight turning plates
 supply of 2-foot long, 2-inch x 2-inch stakes
 double-headed nails (30-40 penny)
 2 carpenter's hammers
 railroad spikes, for checkpoints
 yellow lumber crayon ("keel")
 flagging
 machete, for clearing brush
 30-meter steel tape, with both English and metric units
 shovel
 hand level
 large umbrella
 5-gallon water cooler
 large briefcase or satchel, for storing forms and small supplies

Forms and references

Examples of forms used for geodetic leveling appear in appendix C. NOAA personnel may obtain the forms listed in this manual from:

NOAA Central Logistics Supply Center, 619 Hardesty St. Kansas City, MO 64124. Other users requesting these forms should contact the NGS Vertical Network Division NOS/NOAA, Rockville, MD 20852 (301-443-8567)

Bench Mark Description (NOAA Form 76-186)
 Geodetic Leveling Micrometer Observations (NOAA Form 76-191)
 Geodetic Leveling Three-Wire Observations (NOAA Form 76-189)
 Geodetic Leveling Compensation Check (NOAA Form 77-81)
 Level Line Identification (NOAA Form 76-188)
 Geodetic Leveling Field Abstract (NOAA Form 76-187)
 administrative forms (e.g., weekly and monthly reports, travel vouchers, leave requests)
 description of the leveling line ("logs")
 project instructions

NOAA Manual NOS NGS 3, Geodetic Leveling (this publication)

Input Formats and Specifications of the National Geodetic Survey Data Base, volume II: Vertical control data

Classification, Standards of Accuracy, and General Specifications of Geodetic Control Surveys, Federal Geodetic Control Committee

Specifications to Support Classification, Standards of Accuracy, and General Specifications of Geodetic Control Surveys, Federal Geodetic Committee

Other supplies

notebook
 spare pens
 strapping tape
 paper clips

Computer-recording equipment and supplies

computer-recording system
 power-supply cord and hookup
 battery-charging cord and hookup
 spare batteries
 spare fuses
 set of recording programs
 tapes or disks, in a magnetic-proof storage container
 backup-recording forms: Geodetic Leveling (NOAA Form 77-82)
 instructions and program documentation for the computer-recording system
 colored labels, to identify data tapes and disks
 aluminum mailing containers
 padded envelopes
 pre-addressed mailing labels
 isopropyl alcohol and cotton for cleaning tape recording heads

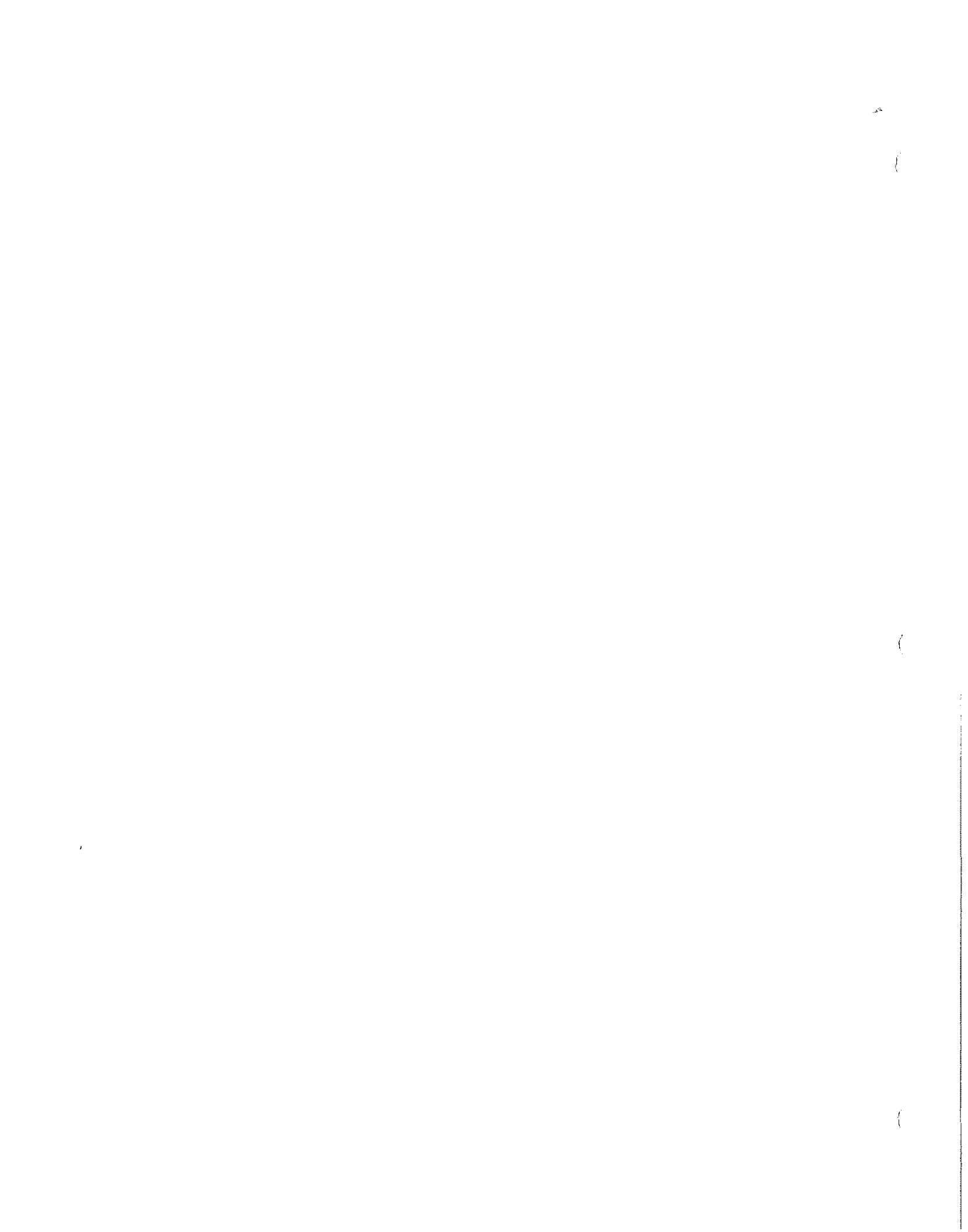

APPENDIX B.—INDEX OF GEODETIC CONTROL DIAGRAMS

Table B.1—Codes for NGS Geodetic Control Diagrams

| Two-letter code | 1° x 2° area designation | Diagram No. | Two-letter code | 1° x 2° area designation | Diagram No. |
|-----------------|--------------------------|-------------|-----------------|--------------------------|-------------|
| AA | Key West | NG-17-11 | CK | Savannah | NI-17-11 |
| AB | Brownsville | NG-14-6,9 | CL | Macon | NI-17-10 |
| AC | Miami | NG-17-8 | CM | Phenix City | NI-16-12 |
| AD | West Palm Beach | NG-17-5 | CN | Montgomery | NI-16-11 |
| AE | McAllan | NG-14-5 | CO | Meridian | NI-16-10 |
| AF | Ft. Pierce | NG-17-2 | CP | Jackson | NI-15-12 |
| AG | Tampa | NG-17-1,4 | CQ | Shreveport | NI-15-11 |
| AH | Corpus Christi | NG-14-3 | CR | Tyler | NI-15-10 |
| AJ | Laredo | NG-14-2 | CS | Dallas | NI-14-12 |
| AK | Orlando | NH-17-11 | CT | Abilene | NI-14-11 |
| AL | Plant City | NH-17-10 | CU | Big Spring | NI-14-10 |
| AM | Bay City | NH-15-10 | CV | Hobbs | NI-13-12 |
| AN | Beeville | NH-14-12 | CW | Carlsbad | NI-13-11 |
| AO | Crystal City | NH-14-11 | CX | Las Cruces | NI-13-10 |
| AP | Eagle Pass | NH-14-10 | CY | Silver City | NI-12-12 |
| AQ | Daytona Beach | NH-17-8 | CZ | Tucson | NI-12-11 |
| AR | Gainesville | NH-17-7 | DA | Ajo | NI-12-10 |
| AS | Apalachicola | NH-16-9 | DB | El Centro | NI-11-12 |
| AT | Brenton Sound | NH-16-7 | DC | San Diego | NI-11-11 |
| AU | New Orleans | NH-15-9 | DD | Georgetown | NI-17-9 |
| AV | Port Arthur | NH-15-8 | DE | Augusta | NI-17-8 |
| AW | Houston | NH-15-7 | DF | Athens | NI-17-7 |
| AX | Segun | NH-14-9 | DG | Atlanta | NI-16-9 |
| AY | San Antonio | NH-14-8 | DH | Birmingham | NI-16-8 |
| AZ | Del Rio | NH-14-7 | DJ | West Point | NI-16-7 |
| BA | Emory Peak | NH-13-9 | DK | Greenwood | NI-15-9 |
| BB | Presidio | NH-13-8 | DL | El Dorado | NI-15-8 |
| BC | Jacksonville | NH-17-5 | DM | Texarkansas | NI-15-7 |
| BD | Valdosta | NH-17-4 | DN | Sherman | NI-14-9 |
| BE | Tallahassee | NH-16-6 | DO | Wichita Falls | NI-14-8 |
| BG | Pensacola | NH-16-5 | DP | Lubbock | NI-14-7 |
| BH | Mobile | NH-16-4 | DQ | Brownfield | NI-13-9 |
| BJ | Baton Rouge | NH-15-6 | DR | Boswell | NI-13-8 |
| BK | Lake Charles | NH-15-5 | DS | Tularosa | NI-13-7 |
| BL | Beaumont | NH-15-4 | DT | Clifton | NI-12-9 |
| BM | Austin | NH-14-6 | DU | Mesa | NI-12-8 |
| BN | Ilano | NH-14-5 | DV | Phoenix | NI-12-7 |
| BO | Sonora | NH-14-4 | DW | Salton Sea | NI-11-9 |
| BP | Ft. Stockton | NH-13-6 | DX | Santa Ana | NI-11-8 |
| BQ | Marfa | NH-13-5 | DY | Long Beach | NI-11-7 |
| BR | Brunswick | NH-17-2 | DZ | Santa Maria | NI-10-6,9 |
| BS | Waycross | NH-17-1 | EA | Beaufort | NI-18-4 |
| BT | Dothan | NH-16-3 | EB | Florence | NI-17-6 |
| BU | Andalusia | NH-16-2 | EC | Spartanburg | NI-17-5 |
| BV | Hattiesburg | NH-16-1 | ED | Greenville | NI-17-4 |
| BW | Natchez | NH-15-3 | EE | Rome | NI-16-6 |
| BX | Alexandria | NH-15-2 | EF | Gadsden | NI-16-5 |
| BY | Palestine | NH-15-1 | EG | Tupelo | NI-16-4 |
| BZ | Waco | NH-14-3 | EH | Helena | NI-15-6 |
| CA | Brownwood | NH-14-2 | EJ | Little Rock | NI-15-5 |
| CB | San Angelo | NH-14-1 | EK | McAlester | NI-15-4 |
| CC | Pecos | NH-13-3 | EL | Aramore | NI-14-6 |
| CD | Van Horn | NH-13-2 | EM | Lawton | NI-14-5 |
| CE | El Paso | NH-13-1 | EN | Plainview | NI-14-4 |
| CF | Douglas | NH-12-3 | EO | Clovis | NI-13-6 |
| CG | Nogales | NH-12-2 | EP | Ft. Sumner | NI-13-5 |
| CH | Lukeville | NH-12-1 | EQ | Socorro | NI-13-4 |
| CJ | James Island | NI-17-12 | ER | St. Johns | NI-12-6 |

Table B.1—Codes for NGS Geodetic Control Diagrams—Continued

| Two-letter code | 1° x 2° area designation | Diagram No. | Two-letter code | 1° x 2° area designation | Diagram No. |
|-----------------|--------------------------|-------------|-----------------|--------------------------|-------------|
| ES | Holbrook | NI-12-5 | HJ | La Junta | NJ-13-9 |
| ET | Prescott | NI-12-4 | HK | Trinidad | NJ-13-8 |
| EU | Needles | NI-11-6 | HL | Durango | NJ-13-7 |
| EV | San Bernadino | NI-11-5 | HM | Cortez | NJ-12-9 |
| EW | Los Angeles | NI-11-4 | HN | Escalante | NJ-12-8 |
| EX | Manteo | NI-18-2 | HO | Cedar City | NJ-12-7 |
| EY | Rocky Mount | NI-18-1 | HP | Caliente | NJ-11-9 |
| EZ | Raleigh | NI-17-3 | HQ | Goldfield | NJ-11-8 |
| FA | Charlotte | NI-17-2 | HR | Mariposa | NJ-11-7 |
| FB | Knoxville | NI-17-1 | HS | San Jose | NJ-10-9 |
| FC | Chattanooga | NI-16-3 | HT | San Francisco | NJ-10-8 |
| FD | Columbia | NI-16-2 | HU | Salisbury | NJ-18-5 |
| FE | Blytheville | NI-16-1 | HV | Washington | NJ-18-4 |
| FF | Memphis | NI-15-3 | HW | Charlottesville | NJ-17-6 |
| FG | Russelville | NI-15-2 | HX | Charleston | NJ-17-5 |
| FH | Ft. Smith | NI-15-1 | HY | Huntington | NJ-17-4 |
| FJ | Oklahoma City | NI-14-3 | HZ | Louisville | NJ-16-6 |
| FK | Clinton | NI-14-2 | JA | Vincennes | NJ-16-5 |
| FL | Amarillo | NI-14-1 | JB | Belleville | NJ-16-4 |
| FM | Tucumcari | NI-13-3 | JC | St. Louis | NJ-15-6 |
| FN | Santa Fe | NI-13-2 | JD | Jefferson City | NJ-15-5 |
| FO | Albuquerque | NI-13-1 | JE | Lawrence | NJ-15-4 |
| FP | Gallup | NI-12-3 | JF | Hutchinson | NJ-14-6 |
| FQ | Flagstaff | NI-12-2 | JG | Great Bend | NJ-14-5 |
| FR | Williams | NI-12-1 | JK | Pueblo | NJ-13-5 |
| FS | Kingman | NI-11-3 | JL | Montrose | NJ-13-4 |
| FT | Trona | NI-11-2 | JM | Moab | NJ-12-6 |
| FU | Bakersfield | NI-11-1 | JN | Salina | NJ-12-5 |
| FV | San Luis Obispo | NI-10-3 | JO | Richfield | NJ-12-4 |
| FW | Eastville | NJ-18-8,11 | JP | Lund | NJ-11-6 |
| FX | Norfolk | NJ-18-10 | JQ | Tonapah | NJ-11-5 |
| FY | Greensboro | NJ-17-12 | JR | Walker Lane | NJ-11-4 |
| FZ | Winston-Salem | NJ-17-11 | JS | Sacramento | NJ-10-6 |
| GA | Johnson City | NJ-17-10 | JT | Santa Rosa | NJ-10-5 |
| GB | Corbin | NJ-16-12 | JU | Wilmington | NJ-18-2 |
| GC | Nashville | NJ-16-11 | JV | Baltimore | NJ-18-1 |
| GD | Dyersburg | NJ-16-10 | JW | Cumberland | NJ-17-3 |
| GE | Poplar Bluff | NJ-15-12 | JX | Clarksburg | NJ-17-2 |
| GF | Harrison | NJ-15-11 | JY | Colombus | NJ-17-1 |
| GG | Tulsa | NJ-15-10 | JZ | Cincinnati | NJ-16-3 |
| GH | Enid | NJ-14-12 | KA | Indianapolis | NJ-16-2 |
| GJ | Woodward | NJ-14-11 | KB | Decatur | NJ-16-1 |
| GK | Perryton | NJ-14-10 | KC | Quincy | NJ-15-3 |
| GL | Dalhart | NJ-13-12 | KD | Moberly | NJ-15-2 |
| GM | Raton | NJ-13-11 | KE | Kansas City | NJ-15-1 |
| GN | Aztec | NJ-13-10 | KF | Manhattan | NJ-14-3 |
| GO | Shiprock | NJ-12-12 | KG | Beloit | NJ-14-2 |
| GP | Marble Canyon | NJ-12-11 | KH | Goodland | NJ-14-1 |
| GQ | Grand Canyon | NJ-12-10 | KJ | Limon | NJ-13-3 |
| GR | Las Vegas | NJ-11-12 | KK | Denver | NJ-13-2 |
| GS | Death Valley | NJ-11-11 | KL | Leadville | NJ-13-1 |
| GT | Fresno | NJ-11-10 | KM | Grand Junction | NJ-12-3 |
| GV | Richmond | NJ-18-7 | KN | Price | NJ-12-2 |
| GW | Roanoke | NJ-17-9 | KO | Delta | NJ-12-1 |
| GX | Bluefield | NJ-17-8 | KP | Ely | NJ-11-3 |
| GY | Jenkins | NJ-17-7 | KQ | Millett | NJ-11-2 |
| GZ | Winchester | NJ-16-9 | KR | Reno | NJ-11-1 |
| HA | Evansville | NJ-16-8 | KS | Chico | NJ-10-3 |
| HB | Paducah | NJ-16-7 | KT | Ukiah | NJ-10-2 |
| HC | Rolla | NJ-15-9 | KU | New York | NK-18-12 |
| HD | Springfield | NJ-15-8 | KV | Newark | NK-18-11 |
| HE | Joplin | NJ-15-7 | KW | Harrisburg | NK-18-10 |
| HF | Wichita | NJ-14-9 | KX | Pittsburgh | NK-17-12 |
| HG | Pratt | NJ-14-8 | KY | Canton | NK-17-11 |
| HH | Dodge City | NJ-14-7 | KZ | Marion | NK-17-10 |

Table B.1—Codes for NGS Geodetic Control Diagrams—Continued

| Two-letter code | 1° x 2° area designation | Diagram No. | Two-letter code | 1° x 2° area designation | Diagram No. |
|-----------------|--------------------------|-------------|-----------------|--------------------------|-------------|
| LA | Muncie | NK-16-12 | NQ | Torrington | NK-13-5 |
| LB | Danville | NK-16-11 | NR | Casper | NK-13-4 |
| LC | Peoria | NK-16-10 | NS | Lander | NK-12-6 |
| LD | Burlington | NK-15-12 | NT | Preston | NK-12-5 |
| LE | Centerville | NK-15-11 | NU | Pocatello | NK-12-4 |
| LF | Nebraska City | NK-15-10 | NV | Twin Falls | NK-11-6 |
| LG | Lincoln | NK-14-12 | NW | Jordan Valley | NK-11-5 |
| LH | Grand Island | NK-14-11 | NX | Adel | NK-11-4 |
| LJ | McCook | NK-14-10 | NY | Klamath Falls | NK-10-6 |
| LK | Sterling | NK-13-12 | NZ | Medford | NK-10-5 |
| LL | Greeley | NK-13-11 | OA | Coos Bay | NK-10-1,4 |
| LM | Craig | NK-13-10 | OB | Bath | NK-19-2 |
| LN | Vernal | NK-12-12 | OC | Portland | NK-19-1 |
| LO | Salt Lake City | NK-12-11 | OD | Glen Falls | NK-18-3 |
| LP | Tooele | NK-12-10 | OE | Utica | NK-18-2 |
| LQ | Elko | NK-11-12 | OF | Rochester | NK-18-1 |
| LR | Winnemucca | NK-11-11 | OG | Toronto | NK-17-3 |
| LS | Lovelock | NK-11-10 | OH | Boise | NK-11-2 |
| LT | Susanville | NK-10-12 | OJ | Flint | NK-17-1 |
| LU | Redding | NK-10-11 | OK | Midland | NK-16-3 |
| LV | Eureka | NK-10-7,10 | OL | Milwaukee | NK-16-2 |
| LW | Providence | NK-19-7 | OM | Madison | NK-16-1 |
| LX | Hartford | NK-18-9 | ON | La Crosse | NK-15-3 |
| LY | Scranton | NK-18-8 | OO | Mason City | NK-15-2 |
| LZ | Williamsport | NK-18-7 | OP | Fairmont | NK-15-1 |
| MA | Warren | NK-17-9 | OQ | Sioux Falls | NK-14-3 |
| MB | Cleveland | NK-17-8 | OR | Mitchell | NK-14-2 |
| MC | Toledo | NK-17-7 | OS | Martin | NK-14-1 |
| MD | Ft. Wayne | NK-16-9 | OT | Hot Springs | NK-13-3 |
| ME | Chicago | NK-16-8 | OU | Newcastle | NK-13-2 |
| MF | Aurora | NK-16-7 | OV | Arminto | NK-13-1 |
| MG | Davenport | NK-15-9 | OW | Thermopolis | NK-12-3 |
| MH | Des Moines | NK-15-8 | OX | Driggs | NK-12-2 |
| MJ | Omaha | NK-15-7 | OY | Idaho Falls | NK-12-1 |
| MK | Fremont | NK-14-9 | OZ | Hailey | NK-11-3 |
| ML | Broken Bow | NK-14-8 | PA | Burns | NK-11-1 |
| MM | North Platte | NK-14-7 | PB | Crescent | NK-10-3 |
| MN | Scottsbluff | NK-13-9 | PC | Roseburg | NK-10-2 |
| MO | Cheyenne | NK-13-8 | PD | Eastport | NL-19-12 |
| MP | Rawlins | NK-13-7 | PE | Bangor | NL-19-11 |
| MQ | Rock Springs | NK-12-9 | PF | Lewiston | NL-19-10 |
| MR | Ogden | NK-12-8 | PG | Lake Champlain | NL-18-12 |
| MS | Brigham City | NK-12-7 | PH | Ogdensburg | NL-18-11 |
| MT | Wells | NK-11-9 | PJ | Kingston | NL-18-10 |
| MU | McDermitt | NK-11-8 | PK | Tawas City | NL-17-10 |
| MV | Vya | NK-11-7 | PL | Traverse City | NL-16-2 |
| MW | Alturos | NK-10-9 | PM | Manitowoc | NL-16-11 |
| MX | Weed | NK-10-8 | PN | Green Bay | NL-16-10 |
| MY | Boston | NK-19-4 | PO | Eau Claire | NL-15-12 |
| MZ | Albany | NK-18-6 | PP | St. Paul | NL-15-11 |
| NA | Binghamton | NK-18-5 | PQ | New Ulm | NL-15-10 |
| NB | Elmira | NK-18-4 | PR | Watertown | NL-14-12 |
| NC | Buffalo | NK-17-6 | PS | Huron | NL-14-11 |
| ND | Erie | NK-17-5 | PT | Pierre | NL-14-10 |
| NE | Detroit | NK-17-4 | PU | Rapid City | NL-13-12 |
| NF | Grand Rapids | NK-16-6 | PV | Gillette | NL-13-11 |
| NG | Racine | NK-16-5 | PW | Sheridan | NL-13-10 |
| NH | Rockford | NK-16-4 | PX | Cody | NL-12-12 |
| NJ | Dubuque | NK-15-6 | PY | Ashton | NL-12-11 |
| NK | Waterloo | NK-15-5 | PZ | Dubois | NL-12-10 |
| NL | Fort Dodge | NK-15-4 | QA | Challis | NL-11-12 |
| NM | Sioux City | NK-14-6 | QB | Baker | NL-11-11 |
| NN | O'Neill | NK-14-5 | QC | Canyon City | NL-11-10 |
| NO | Valentine | NK-14-4 | QD | Bend | NL-10-12 |
| NP | Alliance | NK-13-6 | QE | Salem | NL-10-11 |

Table B.1—Codes for NGS Geodetic Control Diagrams—Continued

| Two-letter code | 1° x 2° area designation | Diagram No. | Two-letter code | 1° x 2° area designation | Diagram No. |
|-----------------|--------------------------|-------------|-----------------|--------------------------|-------------|
| QF | Fredericton | NL-19-9 | RZ | Pullman | NL-11-5 |
| QG | Millinocket | NL-19-8 | SA | Walla Walla | NL-11-4 |
| QH | Sherbrooke | NL-19-7 | SB | Yakima | NL-10-6 |
| QJ | Alpena | NL-17-7 | SC | Hoquiam | NL-10-5 |
| QK | Cheboygan | NL-16-9 | SD | Copalis Beach | NL-10-1,4 |
| QL | Escanaba | NL-16-8 | SE | Campbellton | NL-19-3 |
| QM | Iron Mountain | NL-16-7 | SF | Edmundston | NL-19-2 |
| QN | Rice Lake | NL-15-9 | SG | Hancock | NL-16-1,2 |
| QO | Stillwater | NL-15-8 | SH | Two Harbors | NL-15-3 |
| QP | St. Cloud | NL-15-7 | SJ | Hibbing | NL-15-2 |
| QQ | Milbank | NL-14-9 | SK | Bemidji | NL-15-1 |
| QR | Aberdeen | NL-14-8 | SL | Grand Forks | NL-14-3 |
| QS | McIntosh | NL-14-7 | SM | New Rockford | NL-14-2 |
| QT | Lemmon | NL-13-9 | SN | McClusky | NL-14-1 |
| QU | Ekalaka | NL-13-8 | SO | Watford City | NL-13-3 |
| QV | Hardin | NL-13-7 | SP | Glendive | NL-13-2 |
| QW | Billings | NL-12-9 | SQ | Jordan | NL-13-1 |
| QX | Bozeman | NL-12-8 | SR | Lewistown | NL-12-3 |
| QY | Dillon | NL-12-7 | SS | Great Falls | NL-12-2 |
| QZ | Elk City | NL-11-9 | ST | Choteau | NL-12-1 |
| RA | Grangeville | NL-11-8 | SU | Wallace | NL-11-3 |
| RB | Pendleton | NL-11-7 | SV | Spokane | NL-11-2 |
| RC | The Dalles | NL-10-9 | SW | Ritzville | NL-11-1 |
| RD | Vancouver | NL-10-8 | SX | Wenatchee | NL-10-3 |
| RE | Woodstock | NL-19-6 | SY | Seattle | NL-10-2 |
| RF | Presque Isle | NL-19-5 | SZ | Ft. William | NM-16-10 |
| RG | Quebec | NL-19-4 | TA | Quetico | NM-15-12 |
| RH | Blind River | NL-17-4 | TB | International | NM-15-11 |
| RJ | Sault Sainte | NL-16-6 | TC | Roseau | NM-15-10 |
| RK | Marquette | NL-16-5 | TD | Thief River Falls | NM-14-12 |
| RL | Iron River | NL-16-4 | TE | Devils Lake | NM-14-11 |
| RM | Ashland | NL-15-6 | TF | Minot | NM-14-10 |
| RN | Duluth | NL-15-5 | TG | Williston | NM-13-12 |
| RO | Brainerd | NL-15-4 | TH | Wolf Point | NM-13-11 |
| RP | Fargo | NL-14-6 | TJ | Glasgow | NM-13-10 |
| RQ | Jamestown | NL-14-5 | TK | Havre | NM-12-12 |
| RR | Bismarck | NL-14-4 | TL | Shelby | NM-12-11 |
| RS | Dickinson | NL-13-6 | TM | Cut Bank | NM-12-10 |
| RT | Miles City | NL-13-5 | TN | Kalispell | NM-11-12 |
| RU | Forsyth | NL-13-4 | TO | Sandpoint | NM-11-11 |
| RV | Roundup | NL-12-6 | TP | Okanogan | NM-11-10 |
| RW | White Sulphur | NL-12-5 | TQ | Concrete | NM-10-12 |
| RX | Butte | NL-12-4 | TR | Victoria | NM-10-11 |
| RY | Hamilton | NL-11-6 | TS | Cape Flattery | NM-10-10 |

APPENDIX C.—STANDARD LEVELING FORMS OF THE NATIONAL GEODETIC SURVEY

This section contains the geodetic leveling forms used by the National Geodetic Survey. Reproductions may be made for training purposes or for field use in the event that the supply is temporarily exhausted.

Forms appear in the following order :

NOAA Form 76-60, Report on relocation of bench mark.
NOAA Form 76-186, Bench mark description .
NOAA Form 76-91, Report on condition of survey mark.
NOAA Form 76-159, Weekly report—leveling unit.
NOAA Form 76-187, Geodetic leveling field abstract
NOAA Form 76-188, Geodetic leveling line identification.
NOAA Form 76-189, Geodetic leveling three-wire observations.
NOAA Form 76-191, Geodetic leveling micrometer observations.
NOAA Form 76-198, Monthly report—bench mark and reconnaissance teams.
NOAA Form 76-104, Monthly report—leveling unit
NOAA Form 77-82, Geodetic leveling.
NOAA Form 77-81, Geodetic leveling compensation check
Record of bench mark designations assigned by mark setter.
Check-off list for descriptive editing.
River crossing, simultaneous reciprocal observations
River crossing, Zeiss River Crossing Equipment.
River crossing series.

REPORT ON CONDITION OF SURVEY MARK

Form Approved: OMB -R1923
Approval Expires: April 30, 1983

Name or Designation: _____ Year Established: _____

State: _____ County: _____ Organization Established by: _____

Distance and direction from nearest town: _____

Description published in: (Line book, or quadrangle number) _____

Mark searched for or recovered by: Name - _____

Organization - _____

Date of report _____ Address - _____

Condition of marks: List letters and numbers found stamped in (not cast in) each mark.

| Mark stamped: | Condition: |
|---------------|------------|
| | |
| | |
| | |

Marks accessible? Yes No Property owner contacted? Yes No

Please report on the thoroughness of the search in case a mark was not recovered, suggested changes in description, need for repairing or moving the mark, or other pertinent facts:

This report is authorized by law (Title 33 USC Section 883e). While you are not required to respond, your cooperation is needed to make the results of this survey comprehensive, accurate, and timely.

Witness Post? Yes ___ No ___
Witness Post set ___ feet ___ of ___ mark.
Witness Post set ___ feet ___ of ___ mark.

If additional forms are needed, indicate number required _____

NOAA FORM 76-91 (5-78) U.S. DEPARTMENT OF COMMERCE NATIONAL OCEANIC AND ATMOSPHERIC ADMINISTRATION NATIONAL OCEAN SURVEY

| NOAA FORM 76-159 (3-82) | | U.S. DEPARTMENT OF COMMERCE NATIONAL OCEANIC AND ATMOSPHERIC ADMINISTRATION | | | | | | | | | | | |
|-------------------------------|---------------|--|------------|------------|--------------|---------|----------|------------|-------------|-------------------|-----------|--------------------|-----------------|
| WEEKLY REPORT - LEVELING UNIT | | | | | | | | | | | | | |
| OBSERVER | | | | | RECORDER | | | | | MONTH/YEAR | | | |
| RODMEN, PACER | | | | | PARTY | | | | | | | | |
| LOCATION(S) | | | | | PROJECT | | | | | | | | |
| LINE(S) | | | | | SURVEY ORDER | | | | | CLASS | | | |
| DAY | DISTANCE (km) | | | | | NUMBER | | TIME | | COLL AND COMP CKS | STAFF DAY | WEATHER CONDITIONS | REMARKS |
| | DBL RUN PROG | SGL RUN PROG | 1ST RE-RUN | ADL RE-RUN | TOT ALL RUN | SET UPS | SEC-TION | 1ST SET UP | LAST SET UP | | | | |
| Sun | | | | | | | | | | | | | |
| Mon | | | | | | | | | | | | | |
| Tue | | | | | | | | | | | | | |
| Wed | | | | | | | | | | | | | |
| Thu | | | | | | | | | | | | | |
| Fri | | | | | | | | | | | | | |
| Sat | | | | | | | | | | | | | |
| Total | | | | | | | | | | | | | km/Staff-Days = |

GEODEIC LEVELING LINE IDENTIFICATION

| LINE PART | RELEVEL | FIELD SURVEY DATES | | | | | | UNITS | TOLER- ANCE FACTOR | ORDER & CLASS | STATE CODES | PARTY CHIEF | AGENCY RESPONSIBLE FOR SURVEY |
|--------------------|---------|--------------------|-----|-----|----|------|-----|-------------|--------------------------|------------------|-------------|----------------|-------------------------------|
| | | YEAR | MO. | DAY | TO | YEAR | MO. | | | | | | |
| * 1 0 * | | | | | | | | | | | | | |
| PROJECT/LINE TITLE | | | | | | | | | | | | | |
| * 1 1 * | | | | | | | | | | | | | |
| * 1 2 * | | | | | | | | | | | | | |
| * 1 3 * | | | | | | | | | | | | | |
| * 1 4 * | | | | | | | | | | | | | |
| COMMENTS | | | | | | | | | | | | | |
| * 1 5 * | | | | | | | | | | | | | |
| * 1 5 * | | | | | | | | | | | | | |
| TASK NUMBER | | | | | | | | RODS | | | | | |
| CHIEF OF PARTY | | | | | | | | | | | | | |
| OBSERVERS | | | | | | | | | | | | | |
| RECORDERS | | | | | | | | INSTRUMENTS | | | | | |

**GEODETTIC LEVELING
MICROMETER OBSERVATIONS (Δh)**

| | | | | | | | | | | | | |
|---------|-----|-----|-----|------|-----------------------|---|------|----------------|------|----------------|---|------|
| * 4 0 * | YR. | MO. | DAY | CODE | INSTRUMENT SERIAL NO. | M | CODE | ROD SERIAL NO. | CODE | ROD SERIAL NO. | Z | TIME |
| * 4 1 * | | | | | | | | | | | | |

| | | | | | | | | | | |
|------|----------------|----|----------------|---|-------|-----|-------------|-----|---|-----------|
| FROM | BM DESIGNATION | TO | BM DESIGNATION | Z | TIME | F/C | TEMPERATURE | W | S | OB-SERVER |
| | | | | | BEGIN | END | BEGIN | END | | |

| SET UP# | STADIA BACK | S _B Σ | STADIA FORE | S _F Σ | LOW SCALE BACK/FORE | Δh_{Σ} | HIGH SCALE BACK/FORE | Δh_{Σ} | Δh_{Σ} | REMARKS |
|---------|-------------|------------------|-------------|------------------|---------------------|---------------------|----------------------|---------------------|---------------------|---------|
| | | | | | B | | B | | | |
| | | | | | F | | F | | | |
| | | | | | B | | B | | | |
| | | | | | F | | F | | | |
| | | | | | B | | B | | | |
| | | | | | F | | F | | | |
| | | | | | B | | B | | | |
| | | | | | F | | F | | | |
| | | | | | B | | B | | | |
| | | | | | F | | F | | | |
| | | | | | B | | B | | | |
| | | | | | F | | F | | | |
| | | | | | B | | B | | | |
| | | | | | F | | F | | | |
| | | | | | B | | B | | | |
| | | | | | F | | F | | | |
| | | | | | B | | B | | | |
| | | | | | F | | F | | | |

| SET UP# | STADIA BACK | S _B Σ | STADIA FORE | S _F Σ | LOW SCALE BACK/FORE | Δ _{HL} Σ | HIGH SCALE BACK/FORE | Δ _{HS±d} Σ | Δ _{HL} - Δ _{HS} | REMARKS |
|---------|-------------|---------------------|-------------|---------------------|---------------------|----------------------|----------------------|------------------------|--------------------------------------|---------|
| | | | | | B | | B | | | |
| | | | | | F | | F | | | |
| | | | | | B | | B | | | |
| | | | | | F | | F | | | |
| | | | | | B | | B | | | |
| | | | | | F | | F | | | |
| | | | | | B | | B | | | |
| | | | | | F | | F | | | |
| | | | | | B | | B | | | |
| | | | | | F | | F | | | |
| | | | | | B | | B | | | |
| | | | | | F | | F | | | |
| | | | | | B | | B | | | |
| | | | | | F | | F | | | |
| | | | | | B | | B | | | |
| | | | | | F | | F | | | |
| | | | | | B | | B | | | |
| | | | | | F | | F | | | |
| | | | | | B | | B | | | |
| | | | | | F | | F | | | |

| | | | | | | | | | | | | | | | | | | | | |
|---|-------------------------|-------------------------|------------------|-----------------------------|----------|--------------------|----------|-------|------------------|--|------------------------------|--------------------------------|-------------------|--------------------|-----------------|--------------|------------|---------|--|--|
| NOAA FORM 76-198 (3-82) | | | | | | | | | | U.S. DEPARTMENT OF COMMERCE NATIONAL OCEANIC AND ATMOSPHERIC ADMINISTRATION | | | | | | | | | | |
| MONTHLY REPORT – BENCH MARK AND RECONNAISSANCE TEAMS | | | | | | | | | | | | | | | | | | | | |
| TEAM LEADER | | | | | | | | | | PROJECT DIRECTOR | | | | | | | | | | |
| TEAM ASSISTANT | | | | | | | | | | PARTY | | | | | MONTH/YEAR 19__ | | | | | |
| Date | MARKS SEARCHED FOR | | | | | | | | | | MARKS ESTABLISHED | | | | | TASK NUMBER: | | | | |
| | VERTICAL CONTROL | | | | | HORIZONTAL CONTROL | | | | | | | | | | STATE: | | | | |
| | Recovered Good Cond. | Recovered Poor Cond. | NOT Recovered | Destroyed or Unusable | Stations | Reference Marks | AZ Marks | Other | NOT Recovered | Rock Marks | Quality A Rods Sleeved | Quality A Rods Unsleeved | Quality B Rods | Structure Marks | Line Number | Kilometers | Staff-Days | Remarks | | |
| 1 | | | | | | | | | | | | | | | | | | | | |
| 2 | | | | | | | | | | | | | | | | | | | | |
| 3 | | | | | | | | | | | | | | | | | | | | |
| 4 | | | | | | | | | | | | | | | | | | | | |
| 5 | | | | | | | | | | | | | | | | | | | | |
| 6 | | | | | | | | | | | | | | | | | | | | |
| 7 | | | | | | | | | | | | | | | | | | | | |
| 8 | | | | | | | | | | | | | | | | | | | | |
| 9 | | | | | | | | | | | | | | | | | | | | |
| 10 | | | | | | | | | | | | | | | | | | | | |
| 11 | | | | | | | | | | | | | | | | | | | | |
| 12 | | | | | | | | | | | | | | | | | | | | |
| 13 | | | | | | | | | | | | | | | | | | | | |
| 14 | | | | | | | | | | | | | | | | | | | | |
| 15 | | | | | | | | | | | | | | | | | | | | |
| 16 | | | | | | | | | | | | | | | | | | | | |
| 17 | | | | | | | | | | | | | | | | | | | | |
| 18 | | | | | | | | | | | | | | | | | | | | |
| 19 | | | | | | | | | | | | | | | | | | | | |
| 20 | | | | | | | | | | | | | | | | | | | | |
| 21 | | | | | | | | | | | | | | | | | | | | |
| 22 | | | | | | | | | | | | | | | | | | | | |
| 23 | | | | | | | | | | | | | | | | | | | | |
| 24 | | | | | | | | | | | | | | | | | | | | |
| 25 | | | | | | | | | | | | | | | | | | | | |
| 26 | | | | | | | | | | | | | | | | | | | | |
| 27 | | | | | | | | | | | | | | | | | | | | |
| 28 | | | | | | | | | | | | | | | | | | | | |
| 29 | | | | | | | | | | | | | | | | | | | | |
| 30 | | | | | | | | | | | | | | | | | | | | |
| 31 | | | | | | | | | | | | | | | | | | | | |
| Total | | | | | | | | | | | | | | | | | | | | |

NOAA FORM 76-104 (3-82) U.S. DEPARTMENT OF COMMERCE NATIONAL OCEANIC AND ATMOSPHERIC ADMINISTRATION

MONTHLY REPORT - LEVELING UNIT

OBSERVER _____ RECORDER _____ MONTH/YEAR 19 _____

ROOMEN. PACER _____ PARTY _____

LOCATION(S) _____ PROJECT _____

LINE(S) _____ SURVEY ORDER _____ CLASS _____

| DAY | DISTANCE (km) | | | | | NUMBER | | TIME | | COLL AND COMP CKS | STAFF DAY | DOWN TIME | WEATHER CONDITIONS | REMARKS |
|-------|---------------|--------------|------------|------------|-------------|---------|----------|------------|-------------|-------------------|-----------|-----------|--------------------|-----------------|
| | DBL RUN PROG | SGL RUN PROG | 1ST RE-RUN | ADL RE-RUN | TOT ALL RUN | SET UPS | SEC-TION | 1ST SET UP | LAST SET UP | | | | | |
| 1 | | | | | | | | | | | | | | |
| 2 | | | | | | | | | | | | | | |
| 3 | | | | | | | | | | | | | | |
| 4 | | | | | | | | | | | | | | |
| 5 | | | | | | | | | | | | | | |
| 6 | | | | | | | | | | | | | | |
| 7 | | | | | | | | | | | | | | |
| 8 | | | | | | | | | | | | | | |
| 9 | | | | | | | | | | | | | | |
| 10 | | | | | | | | | | | | | | |
| 11 | | | | | | | | | | | | | | |
| 12 | | | | | | | | | | | | | | |
| 13 | | | | | | | | | | | | | | |
| 14 | | | | | | | | | | | | | | |
| 15 | | | | | | | | | | | | | | |
| 16 | | | | | | | | | | | | | | |
| 17 | | | | | | | | | | | | | | |
| 18 | | | | | | | | | | | | | | |
| 19 | | | | | | | | | | | | | | |
| 20 | | | | | | | | | | | | | | |
| 21 | | | | | | | | | | | | | | |
| 22 | | | | | | | | | | | | | | |
| 23 | | | | | | | | | | | | | | |
| 24 | | | | | | | | | | | | | | |
| 25 | | | | | | | | | | | | | | |
| 26 | | | | | | | | | | | | | | |
| 27 | | | | | | | | | | | | | | |
| 28 | | | | | | | | | | | | | | |
| 29 | | | | | | | | | | | | | | |
| 30 | | | | | | | | | | | | | | |
| 31 | | | | | | | | | | | | | | |
| Total | | | | | | | | | | | | | | km/Staff-Days = |

GEODETIC LEVELING

| | | | | | | | | | | | | | | | | | | | | | | | | |
|-----------------------|--|--|-------------|--|-----------|-------------|--|--|------------------|--------------------|--|------|--|--|------------|--|--|------|--|-------|-------|--|--|--|
| LINE | | | | | | | | | | TAPE NO. | | | | | | | | | | | | | | |
| PROJ. NO. | | | | | PAGE | | | | | OF | | | | | | | | | | | | | | |
| ST 0 | | | ST 1 | | | ST 2 | | | ST 3 | | | | | | | | | | | | | | | |
| DATA | | | YR. MO. DY. | | | ZONE | | | INST. NO. | | | CODE | | | | | | | | | | | | |
| * 4 0 * | | | | | | | | | | | | | | | | | | | | | | | | |
| ST 4 | | | | | ST 5 | | | | | | | | | | | | | | | | | | | |
| ROD NO. 1 | | | | | ROD NO. 2 | | | | | | | | | | | | | | | | | | | |
| | | | | | | | | | | | | | | | | | | | | | | | | |
| ST 6 | | | ST 7 | | | ST 8 | | | ST 9 | | | C | | | | | | | | | | | | |
| OBSERVER | | | TIME | | | LEVEL CONST | | | C / F UNITS STAD | | | F | | | | | | | | | | | | |
| | | | | | | | | | | | | B | | | | | | | | | | | | |
| 0 - WRITE ON TAPE - 9 | | | | | | | | | | BLOCK | | | | | - | | | | | | | | | |
| ST 0 | | | ST 1 | | | DESIGNATION | | | | | | | | | | | | | | | | | | |
| DATA | | | FROM: | | | | | | | | | | | | | | | | | | | | | |
| * 4 1 * | | | | | | | | | | | | | | | | | | | | | | | | |
| | | | ST 2 | | | DESIGNATION | | | | | | | | | | | | | | | | | | |
| | | | TO: | | | | | | | | | | | | | | | | | | | | | |
| | | | | | | ST 3 | | | ST 4 | | | ST 5 | | | ST 6 | | | ST 7 | | | BLOCK | | | |
| | | | | | | TIME | | | TEMP | | | WIND | | | SUN | | | DATE | | | - | | | |
| | | | | | | | | | | | | | | | | | | | | | | | | |
| 0 - WRITE ON TAPE - 7 | | | | | | | | | | S - CLR | | | | | q = | | | | | | | | | |
| ST "q" IN CHG SIGN | | | | | | | | | | (NOTE SIGN OF "q") | | | | | | | | | | J.S.S | | | | |
| ELEV. DIFF. | | | | | RCL 7 | | | | | KM. RCL * | | | | | NO. RCL. 0 | | | | | | | | | |
| | | | | | | | | | | | | | | | | | | | | | | | | |
| ST 0 | | | ST 1 | | | ST 2 | | | ST 3 | | | ST 4 | | | BLOCK | | | | | | | | | |
| DATA | | | TIME | | | TEMP | | | WIND | | | SUN | | | OBS. REC. | | | | | | | | | |
| * 4 1 * | | | | | | | | | | | | | | | | | | | | | | | | |
| 0 - WRITE ON TAPE - 4 | | | | | | | | | | | | | | | | | | | | | | | | |
| REMARKS | | | | | | | | | | REMARKS | | | | | | | | | | | | | | |
| Rod 1 (initials) | | | | | | | | | | Rod 2 (initials) | | | | | | | | | | | | | | |

GEODETTIC LEVELING COMPENSATION CHECK

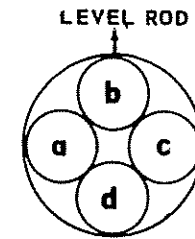

BUBBLE POSITION

INSTRUMENT: Zeiss Ni 1/

| | | | | |
|------|-----|------|------|---------------|
| WIND | SUN | TIME | DATE | SERIAL NUMBER |
| | % | | | |

If $\tan \alpha$ or $\tan \beta < 0.000097$ the compensator is in good adjustment.

| POSITION OF BUBBLE | HALF STADIA | ROD LEFT HALF cm | ROD RIGHT HALF cm | HALF STADIA INTERCEPT (HSI) | POSITION OF BUBBLE | ROD LEFT HALF cm | ROD RIGHT HALF cm |
|--------------------|-------------|------------------|-------------------|-----------------------------|--------------------|------------------|-------------------|
| a | | | | | c | | |
| | | | | | | | |
| | a | | | | | | |
| | a - c | | | | | | |

$$\text{Mean (a-c)}_{\text{cm}} = \frac{(a-c)_{\text{left}} + (a-c)_{\text{right}}}{4}$$

$$S_{\text{cm}} = \text{HSI} \times \text{Stadia Constant} =$$

$$\tan \alpha = \frac{a-c}_{\text{cm}}}{S_{\text{cm}}}$$

REMARKS (OBSERVER/RECORDER)

| | | | | | | | |
|----------|-------|--|--|--|----------|--|--|
| b | | | | | d | | |
| | | | | | | | |
| | b | | | | | | |
| | b - d | | | | | | |

$$\text{Mean (b-d)}_{\text{cm}} = \frac{(b-d)_{\text{left}} + (b-d)_{\text{right}}}{4}$$

$$\tan \beta = \frac{b-d}_{\text{cm}}}{S_{\text{cm}}}$$

REMARKS (OBSERVER/RECORDER)

RIVER CROSSING
Simultaneous Reciprocal Observations

42

| | | |
|-----|-----|-----|
| YR. | MO. | DAY |
| | | |

FROM

| | | |
|--|--|--|
| | | |
|--|--|--|

 (BM A) TO

| | | |
|--|--|--|
| | | |
|--|--|--|

 (BM B)

RUN _____

| | | | | |
|---|-------|--|-----|--|
| Z | TIME | | | |
| | BEGIN | | END | |
| | | | | |

| | Δh | S | Mean of Set |
|-------------------------------|------------|-------|----------------------|
| Set 1 | | | |
| Side A (Instrument 1) F _____ | | _____ | $\Delta h_1 =$ _____ |
| Side B (Instrument 2) B _____ | | _____ | |

| | | | | |
|-------------------------------|--|-------|----------------------|----------------|
| Set 2 | | | $\Delta H =$ _____ m | $S =$ _____ km |
| Side A (Instrument 2) F _____ | | _____ | $\Delta h_2 =$ _____ | |
| Side B (Instrument 1) B _____ | | _____ | | |

RIVER CROSSING
Zeiss River Crossing Equipment

42

| | | |
|-----|-----|-----|
| YR. | MO. | DAY |
| | | |

FROM

| | | | |
|--|--|--|--|
| | | | |
|--|--|--|--|

(BM A)

TO

| | | | |
|--|--|--|--|
| | | | |
|--|--|--|--|

(BM B)

RUN

| | | | | |
|---|-------|--|-----|--|
| Z | TIME | | | |
| | BEGIN | | END | |
| | | | | |

LEVELING At Side B:

| | | | | |
|--------|---|-------|-------|-------|
| | | Δh | | S |
| Before | F | _____ | _____ | _____ |
| Before | B | _____ | _____ | _____ |
| After | F | _____ | _____ | _____ |
| After | B | _____ | _____ | _____ |

LEVELING At Side A:

| | | | | |
|--------|---|-------|-------|-------|
| | | Δh | | S |
| Before | F | _____ | _____ | _____ |
| Before | B | _____ | _____ | _____ |
| After | F | _____ | _____ | _____ |
| After | B | _____ | _____ | _____ |

Height Stud B to BM B _____ (Mean) _____

Height Stud A to BM A _____ (Mean) _____

SERIES At Side A:
BM A to Height Stud B _____

SERIES At Side B:
BM B to Height Stud A _____

BM A to BM B = Δh_A = _____ S_A = _____

BM B to BM A = Δh_B = _____ S_B = _____

$$\Delta H = \frac{1}{2} \times (\Delta h_A - \Delta h_B) = \text{_____ m}$$

$$S = \frac{1}{2} \times (S_A + S_B) = \text{_____ km}$$

RIVER CROSSING SERIES, SIDE _____

PAGE _____
OF _____

| | | YR. | MO. | DAY | CODE | INSTRUMENT SERIAL NO. | CODE | INSTRUMENT SERIAL NO. | CODE | ROD SERIAL NO. | TARGET POSITIONS, THIS SIDE | | RUN NO. | | | | | | | |
|------------------|----------|--------------------------|-------|-------|------|-----------------------|-------|-----------------------|------|----------------|-----------------------------|--------------|-------------|-----------------------|-----|---|-----------|--|--|---|
| • 4 2 • | | | | | | | | | | | TOP | BOTTOM | | | | | | | | |
| FROM | | DESIGNATION | | | | TO | | DESIGNATION | | Z | TIME | | TEMPERATURE | | W | S | OB-SERVER | | | |
| | | | | | | | | | | | BEGIN | END | F/C | BEGIN | END | | | | | |
| INSTRUMENT No. 1 | | | | | | INSTRUMENT No. 2 | | | | | | COMPUTATIONS | | | | | | | | |
| BACKSIGHT | B M | ↓ RECIPROCAL COLLIMATION | | | | | | | | | | | | GRADUATIONS: - * | | | | | | |
| | | ROD | | LOWER | | | | LOWER | | | | | | | | | | | | + |
| | | UPPER | | | | UPPER | | | | | | | | | | | | | | |
| FORESIGHT | SET 1 | ↑ RECIPROCAL COLLIMATION | | | | | | | | | | | | TARGETS OPPOSITE: - = | | | | | | |
| | | TARGET | | LOWER | | 10.00 | | LOWER | | | | | | | | | | | | + |
| | | | UPPER | | | | UPPER | | | | | | | | | | | | | |
| | SET 2 | ↓ RECIPROCAL COLLIMATION | | | | | | | | | | | | | | | | | | |
| | | TARGET | | LOWER | | 10.00 | | LOWER | | | | | | | | | | | | - |
| | | | UPPER | | | | UPPER | | | | | | | | | | | | | |
| | SET 3 | ↑ RECIPROCAL COLLIMATION | | | | | | | | | | | | | | | | | | |
| | | TARGET | | LOWER | | 10.00 | | LOWER | | | | | | | | | | | | + |
| | | | UPPER | | | | UPPER | | | | | | | | | | | | | |
| | SET 4 | ↓ RECIPROCAL COLLIMATION | | | | | | | | | | | | | | | | | | |
| TARGET | | LOWER | | 10.00 | | LOWER | | | | | | | | | | | | | | |
| | | UPPER | | | | UPPER | | | | | | | | | | | | | | |
| BACKSIGHT | B M | ↑ RECIPROCAL COLLIMATION | | | | | | | | | | | | | | | | | | |
| | | ROD | | LOWER | | | | LOWER | | | | | | | | | | | | |
| | | UPPER | | | | UPPER | | | | | | | | | | | | | | |
| REMARKS | | | | | | | | | | | | | | | | | | | | |

(

(

(

INDEX

- abstract, field:
 - adjustments, 5-26
 - computing, 5-17
 - description, 3-69, 3-70, 3-71, 3-72, 515
 - double-run leveling, 3-71
 - example, computer produced, 5-18
 - office, 5-25
 - proofing, 5-15, 5-17
- accuracy, criteria for:
 - surveys and maps, 1-5, 2-21, 3-11
 - Federal Geodetic Control Committee, 2-25, 2-34, 2-45, 3-11
 - accessioning, 5-23
- adjustment:
 - data, 5-23, 5-26
 - geodetic level:
 - circular level, 3-26, 3-46
 - collimation, 3-25
 - computing corrections, 3-29, 3-31
 - main bubble, 3-25
 - parallax, 3-26
 - quality control, 5-23
 - wedge reticle, 3-27
 - rod levels, 3-42
- airports, leveling to, 2-22
- archival cross-reference number, 2-38
- area leveling, 2-22, 2-23
- atmosphere, effect on leveling, 3-3
 - air temperature differences, measurement, 3-49, 3-50
- B + F: also, see divergence of runnings, allowable
 - accumulation, 3-6, 3-7, 3-65
 - control, 3-52
 - computation, 3-65, 3-66
- backsights and foresights:
 - length, 3-7
 - difference, 3-7
 - equalization, 3-7
 - maximum, 3-7
- battery care, 3-68
- bench mark form:
 - description, 2-34, 2-35, 2-36, 2-38, 2-46
 - illustrations, 2-35, 2-36, 2-37, 2-40, 2-41, 2-46, appendix C
- bench marks:
 - airport, 2-21, 2-22
 - concrete post:
 - construction, 2-41
 - specifications, 2-26
 - designations, 2-26, 2-39
 - destroyed, 2-25
 - locations, 2-20, 2-26, 2-27, 2-45
 - National Ocean Survey, 2-43
 - other organizations:
 - connection, 2-21
 - description, 2-39, 2-40
 - designation, 2-39
 - permanent:
 - description, 2-26, 2-27, 2-28, 2-34, 2-35, 2-36, 5-10, 5-11
 - checking, 5-7
 - data files, 5-9
 - data processing, 5-7, 5-8
 - designation, 2-26
 - establishment, 2-26, 2-27, 2-28
 - horizontal control and three dimensional stations, 2-21, 2-22, 2-40
 - junctions, 2-38
 - spacing, 2-20
 - stamping, 2-39, 2-43
 - designations, 2-39
 - recovery, 2-25
 - recovery notes, 2-36, 2-37, 2-38, 2-47
 - quality classification, 2-42
 - tidal:
 - connections, 2-21
 - designation, 2-16, 2-38, 2-39
 - traverse stations, 2-21, 2-22
- bench mark setting unit:
 - assistant mark setter, 2-1
 - equipment, 2-2
 - foreman, 2-1
 - mark setter, 2-1
 - organization, 2-1
- blunders: also, see errors
 - guarding against, 3-5, 3-6
 - mistakes, 3-5, 3-6
- brace poles, 3-42
- bridges, 2-27, 2-41
- "C":
 - computation, 5-24
 - determination, 3-29, 3-30, 3-31, 3-32, 3-33
 - record, 3-32
- calibration with laser interferometer, 3-43
- check: see B + F and divergence of runnings, allowable
- check abstract: 3-69, 3-70
 - computerized, 5-15, 5-16, 5-17, 5-18, 5-19
 - handwritten, 3-69, 3-70
- check loops, 5-22
- check points, 3-60
- circular level, adjustment: 3-26
 - closing the section, 3-65
 - rejection procedure, 3-66
- collimation, 3-3, 3-4, 3-29, 3-30, 3-31
 - error factor, 3-22, 5-24

- Kukkamaki's method, 3-32, 3-33, 3-34, 3-35
- 10-40 method, 3-33, 3-36, 3-37
- compensation check, 3-34, 3-39, 3-40
- computation:
 - B + F, 3-65, 3-66
 - "C", 3-29, 3-30, 3-31, 3-32, 3-32
 - stadia constant, 3-27, 3-28, 3-29
 - river-crossing observations, 4-16, 4-17
- computation check, 3-34, 3-39, 3-40
- computer:
 - equipment, 3-68
- connections, 2-21, 2-22, 2-23
- control points, 2-8, 2-20, 2-40
 - descriptions, 2-8, 2-40, 2-41
 - destroyed, 2-25, 2-45
 - geographic positions, 2-25, 2-40
 - new, 2-45
 - recovery, 2-25
 - setting new monument, 2-44, 2-45
- corrections:
 - curvature, 5-26
 - refraction, 5-26
- data processing:
 - adjustment, 5-23
 - equipment, 5-1
 - project report, 5-4
 - proofreading, 5-7, 5-8, 5-9, 5-10, 5-13, 5-15
 - records, 5-2
 - submission, 5-2, 5-3, 5-23
 - sets, 5-13
 - verification, 5-23, 5-24
- datums, 1-4
- descriptions, 2-34, 2-38, 2-39, 2-40, 2-41, 2-42, 2-43, 2-44
 - other organizations, 2-39, 2-40
 - processing, 2-23, 5-7, 5-8, 5-9, 5-10, 5-11, 5-12, 5-13
- divergence of runnings, allowable: also, see B + F, 3-6, 3-7
 - not to be exceeded, 3-7
 - tables, 3-7
- editing records: 5-9
- elevations:
 - computing, 5-20, 5-21
 - differences, 5-20
- equipment:
 - bench mark setting unit, 2-1, appendix A
 - computer-recording, 3-68
 - leveling, 3-8, appendix A
 - supplies, appendix A
 - truck, appendix A
- errors: also, see blunders
 - collimation, 3-2, 3-3, 5-24
 - curvature, 3-4
 - leveling, 3-1, 3-2, 3-3, 3-4, 3-5, 3-6
 - refraction, 3-3
 - rod plumb, 3-4
 - scale imperfections, 5-24
 - shimmer, 3-4
 - steep grades, 2-20
 - tidal deflection, 3-4
- field records, 3-66
- flagman, 3-8
- foresights and backsights: see backsights and foresights
- forms, blank, appendix C
 - mark setting, appendix A, appendix C
 - leveling, appendix A, appendix C
- formula:
 - "C", 3-29, 3-31
 - stadia constant, 3-27, 3-28
- General Adjustment of 1929, 1-4
- Geodetic Control Diagram, 2-7
 - codes, appendix B
- geopotential number, 1-4
- graduations:
 - rods:
 - feet, 3-41
 - meters, 3-41
 - scarred, 3-44
- gravity field, 2-22
- hand level, 3-48
- height systems, 1-3, 1-4
- highways:
 - leveling along, 2-2, 2-9
- history of geodetic leveling, 1-1, 1-2, 1-3, 1-4
- Index, area lines, 2-7
- Index to Topographic Maps, 2-8
- instructions:
 - general, 3-51
 - project, 2-4
 - recovery and stamping, 2-25
 - river crossings, 4-1
- instruments:
 - carrying the level, 3-25, 3-44
 - classification, 3-11
 - compensator type:
 - general description, 3-15, 3-18
 - Jenoptik NI 002, 3-15, 3-20, 3-21
 - MOM NiA31, 3-14, 3-15
 - Zeiss Ni1, 3-14, 3-15, 3-19, 3-20, 3-39
 - Zeiss Ni2, 3-14, 3-15, 3-17, 3-18, 3-19, 4-5
 - Wild NA2, 3-15
 - maintenance, 3-27
 - micrometer, 3-22, 3-23
 - spirit level:
 - Breithaupt NABON, 3-15
 - Fischer, 3-13, 3-15, 4-20
 - Jenoptik Ni-004, 3-13, 3-15
 - Wild N3, 3-15
 - telescopic system, 3-13, 3-16
 - Zeiss River Crossing Equipment, 4-5, 4-6, 4-9, 4-10, 4-11, 4-12, 4-28

- junction point positions, 2-19
- junctions:
 - beginning of lines, 2-19
 - code, 2-38
 - ending of lines, 2-19, 2-20
- Kukkamaki's collimation method, 3-31
- length of sections, 2-20
- length of sights: see backsights and foresights,
 - length of
- level: also, see instruments
 - bubble, 3-25
 - geodetic:
 - adjustment, 1-4
 - description, 1-4
 - shading, 3-2
 - shipment, NI 002, 3-27
- leveling:
 - along highways, 2-2, 2-9
 - along railroads, 2-2
 - area, 2-21
 - records, 2-23
 - classification, 2-26, 2-27, 2-42
 - micrometer, 3-53, 3-54, 3-55, 3-56, 3-57
 - procedure, 3-1, 3-2
 - party:
 - organization, 3-6, 3-7
 - personnel, 3-6, 3-7, 3-8
 - rod: see rod
 - safety, 3-9
 - three-wire leveling, 3-56, 3-57, 3-58, 3-59
 - tolerances, 3-7
- logs: see maps for organizing surveys
- loops, 5-22
- magnetic disks, 5-2
- magnetic tape, 5-2
- maps:
 - for organizing surveys, 2-4, 2-23
 - for position plots, 2-9, 2-29
- mark setting unit, 2-1
 - equipment, 2-2
 - personnel, 2-1
 - reports, 2-2, 2-3
 - safety, 2-2
- micrometer, 3-22, 3-23, 3-53
 - foot screws, 3-24
 - reversing point, 3-53, 3-54, 3-55
 - tribrach, 3-24
 - use, 3-23
 - river crossings, 4-20
- mistakes: see errors
- motorized leveling, 3-8
- National Geodetic Vertical Network, 1-4
- network classifications, 1-5
- notes:
 - for use in studying errors, 3-59
 - in remarks column, 3-59
- observation file, 5-3, 5-4
 - vertical observational data set, 5-3, 5-4
- observations:
 - creating file, 5-13, 5-14
 - recomputing computer recorded data, 5-13
 - recording, 3-66
 - rejection, 3-66, 3-67
 - Zeiss River Crossing Equipment, 4-10, 4-11, 4-12, 4-13, 4-14, 4-15, 4-16
- observer:
 - duties, 3-8
 - qualifications, 3-8
- observing:
 - routine, 3-51, 3-52
 - routine for three-wire leveling, 4-18
- program: see program, observing
- unit:
 - discipline, 3-6, 3-7
 - management, 3-6, 3-7
 - organization, 3-6, 3-7, 3-48
- organization,
 - bench mark setting unit, 2-1
 - observing unit, 3-6, 3-7, 3-48
- orthometric height, 1-3
- outfit: see equipment
- parallax, 3-3
- party: see:
 - bench mark setting unit,
 - leveling, party,
 - observing unit,
 - river crossing,
- personnel: also, see party
 - computer, 5-1
 - assistant computer, 5-1
 - flagman, 3-8
 - foreman, 2-1
 - mark setter, 2-1
 - assistant mark setter, 2-1
 - observer, 3-6, 3-8
 - pacer, 3-6
 - project director, 2-1, 5-1
 - assistant project director, 5-1
 - recorder, 3-6, 3-8, 3-9
 - rodman, 3-6, 3-8, 3-9
 - umbrella, person holding, 3-8
 - unit chief, 3-7
- plate turning, 5-47
- plots, smooth, 2-29, 2-33
- plots, working, 2-24, 2-38
- plug: see spacer, 3-60
- points, control:
 - awkward, 3-62
 - check, 2-25
 - description, 2-8
 - identifying, 3-60
 - leveling to, 3-61, 3-62, 3-63
 - precautions to leveling, 3-59

- short scale, 3-63, 3-64
- upside down scale, 3-65
- program:
 - observing, 3-51
 - river crossings, 4-10
 - proofreading: see data processing
- reconnaissance, 2-1, 2-4
- recorder:
 - duties, 3-8
 - qualifications, 3-8
 - training, 3-7
- records, 2-23, 3-66
 - editing, 5-9
 - file status sheet, 5-11
 - recording observations, 3-66
 - transmittal, 2-23
 - submission, 3-72
 - synoptic file, 5-12
- recovery and stamping of bench marks:
 - bench marks, recovery, 2-25
 - control points, 2-25
 - code, 2-41
- refraction: also, see curvature and refraction
 - effect on leveling, 3-3
 - effect on river crossings, 4-2
 - elimination of effect, 3-3
- rejections, 3-66, 3-67
- releveling, 3-65, 3-67
- relocating vertical control points, 2-44
- reports:
 - condition of bench mark, 2-42
 - leveling, weekly, 3-9, 3-10, 3-11
 - leveling, miscellaneous, 2-4, 3-11
 - leveling, monthly, 3-9, 3-10, 3-11, 3-12
 - leveling, vehicle, 3-11
 - mark setting, miscellaneous, 2-4
 - mark setting, monthly, 2-2, 2-3, 2-4
 - mark setting, truck, 2-4
- river or valley crossing
 - auxiliary scale, 4-7, 4-8
 - computation, 4-16, 4-17
 - environmental conditions, 4-5
 - equipment, 4-5
 - Fischer level, 4-20
 - instructions, 4-1, 4-2, 4-3, 4-7
 - instrument station, 4-7
 - leveling rod, 4-8
 - observations, 4-10, 4-11, 4-13
 - ordinary leveling instruments, 4-17, 4-18, 4-19, 4-21, 4-22
 - personnel, 4-4
 - reconnaissance and mark setting, 4-4
 - records of observations, 4-2
 - target stations, 4-8
 - Zeiss River Crossing Equipment, 4-5, 4-9, 4-10, 4-11, 4-12, 4-13, 4-14, 4-15, 4-16, 4-18
- rod:
 - double run, 3-71
 - leveling, 3-4, 3-5
 - marks, 2-27
 - plumb, 3-45
 - pole, 3-43
 - scale, 3-41, 3-42
 - setup, 3-45
 - single run, 3-71
- routes, 2-19
- routing level line, 2-4
 - junctions, 2-19
 - data, 2-4
 - liaison, 2-1, 2-9
 - logs, 2-23
 - specifications, 2-19
- runnings: also, see B + F
 - safety, 2-2
- scale auxiliary, 4-7, 4-8
- scaling positions, 2-30, 2-31, 2-32
- shimmer, 3-3
- sights: see
 - backsights and foresights
- site selection, 2-26, 2-27
- spurs, 2-19
- spacer (plug), 3-60, 3-62
- stability, 2-26, 2-27
- stadia:
 - constant, 3-27, 3-28
 - interval, 3-7
 - method, determination, 3-28
- stamping of bench marks, 2-26
- Sun:
 - direction, 3-50
- sunshade, 3-2
- supplies: appendix A
- survey point serial number, 2-34, 5-12, 5-19
- synoptic file comparison, 2-14, 2-15, 5-10, 5-12
- tables:
 - allowable divergence between runnings, 3-7
 - curvature and refraction, 3-31
- target for river crossings, 4-7
 - column, 4-7
- temperatures:
 - reading, 3-49, 3-50
 - recording, 3-49
- leveling in extreme conditions, 3-50
- thermometer, on rod, 3-49
- three-wire leveling, 3-56, 4-18
- tide stations, 2-9, 2-16, 2-21, 2-38, 2-39
- tidal accelerations, 3-4, 5-26
- time zone, U.S. Navy, 3-68
- tolerances, 3-7
- tools:
 - leveling, 3-8
 - mark setting, 2-2
- traffic, 3-10
- tribrach, 3-24, 4-7

tripod, 3-23
turning pin, 3-46
turning plate, 3-47, 3-48
turning point, 3-46

umbrella, duties of person holding umbrella, 3-8
unit:
 four-person, 3-48
 chief, 3-7, 3-8
U.S. Geological Survey, 1-2, 2-40

valley crossing: see river crossing
verification data, 5-24
vertical control data, 2-10, 2-11, 2-12, 2-13, 2-14,
 2-15
water level station, 2-21, 2-39
wind:
 eliminating effect of, 3-50
 strength, 3-50, 3-51
witness post:
 establishment, 2-25

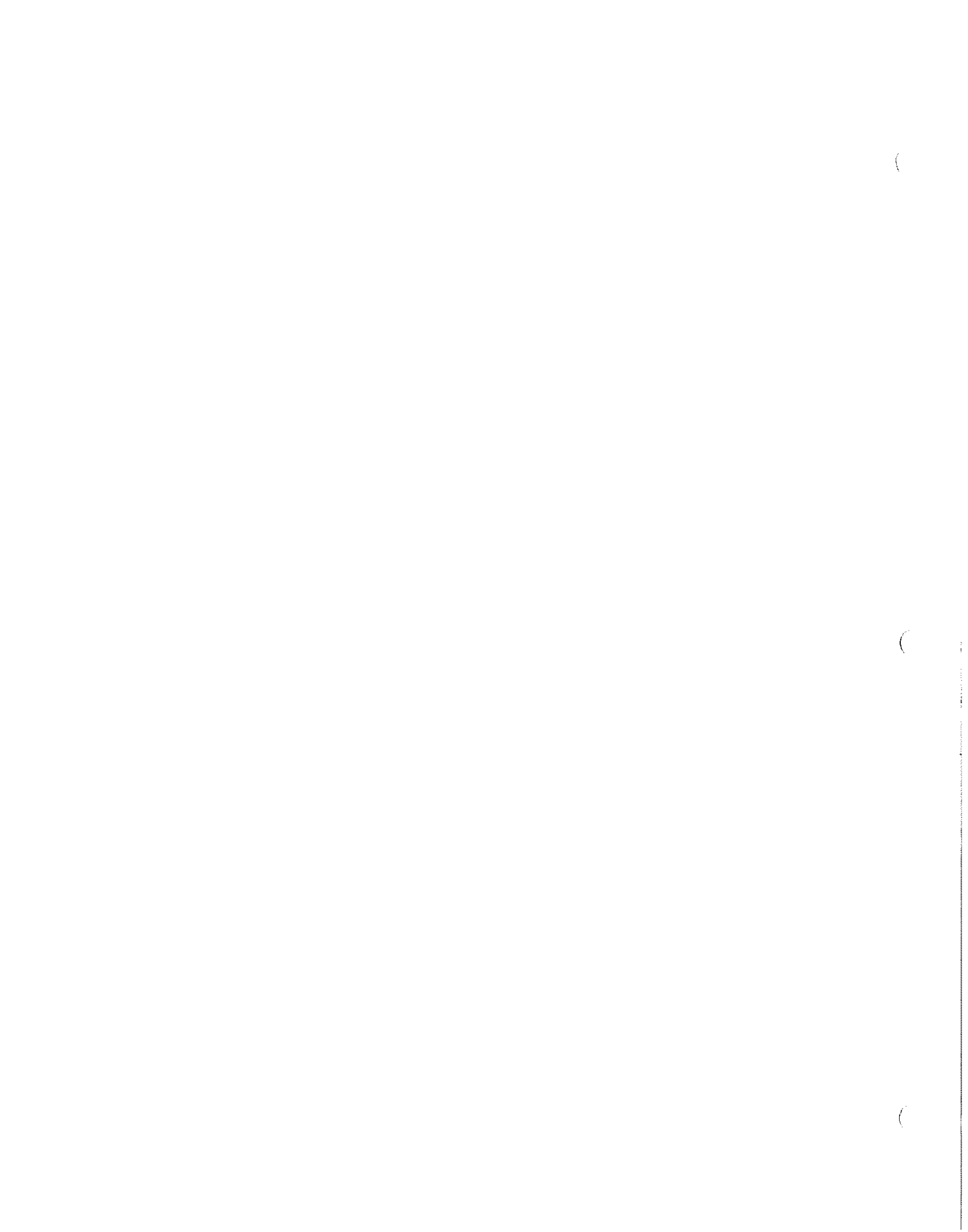





National Geodetic Survey
motorized leveling system.

